



GSLV-F11/GSAT-7A Launch Kit





CONTENTS

Mission Description	3
Flight Sequence & Events	4
GSLV-F11	5
GSAT-7A	6
Glimpses	7

MISSION DESCRIPTION

Geosynchronous Satellite Launch Vehicle – F11 (GSLV-F11) is the 13th flight of India's GSLV and the 7th flight of GSLV with Indigenous Cryo stage.

The GSLV-F11 will place 2250 kg GSAT-7A communication satellite into a Geosynchronous Transfer Orbit. It will be launched from the Second Launch Pad (SLP) at Satish Dhawan Space Centre SHAR, Sriharikota.

TARGETED GEOSYNCHRONOUS TRANSFER ORBIT

Perigee	170 ± 3 km
Apogee	33190 to 40600 km
Inclination	19.35 ± 0.1 degree

GSAT-7A is the 35th Indian Communication satellite built by ISRO. The Satellite is built to provide communication capability to the users in Ku-band over the Indian region.

GSLV – F11



GSAT-7A



GSLV-F11 FLIGHT SEQUENCE

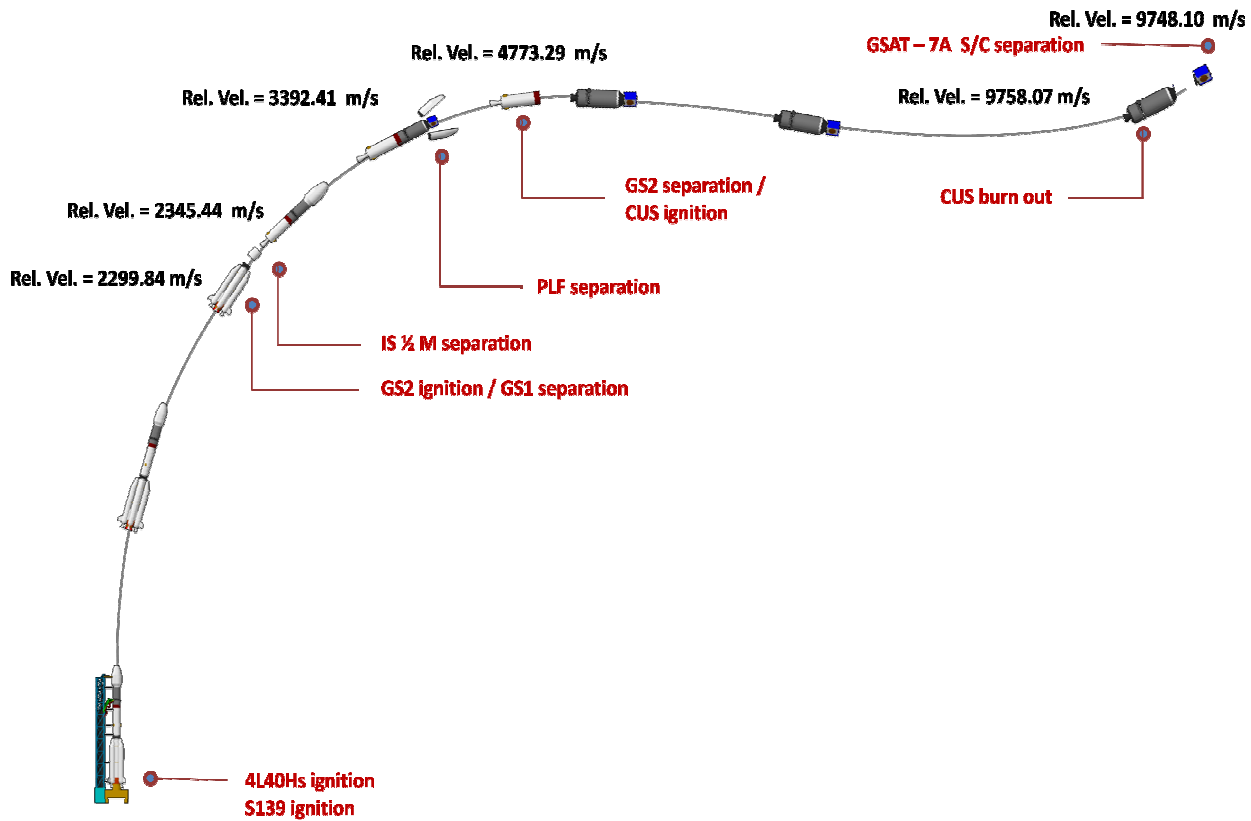

GSLV-F11 FLIGHT EVENTS

Events	Time (s)	Altitude (km)	Relative velocity (m/s)	Inertial velocity (m/s)
Strap-ons ignition	-4.8	0.03	0	451.92
Core stage ignition	0	0.03	0	451.92
Strap-ons shut-off	149.00	69.62	2298.85	2722.31
Second stage ignition	149.60	70.06	2299.84	2723.57
First stage separation	151.20	71.24	2298.08	2722.56
Payload fairing separation	234.70	115.15	3392.41	3836.57
Second stage shut-off	291.36	132.10	4750.57	5197.15
Second stage separation	294.86	133.01	4773.29	5220.00
Cryogenic upper stage ignition	295.86	133.26	4772.81	5219.56
Cryogenic upper stage shut-off	1137.70	253.75	9758.52	10210.97
Cryogenic upper stage burn out	1142.70	259.10	9758.07	10210.73
GSAT-7A S/C separation	1152.70	270.30	9748.10	10201.19

GSLV - F11

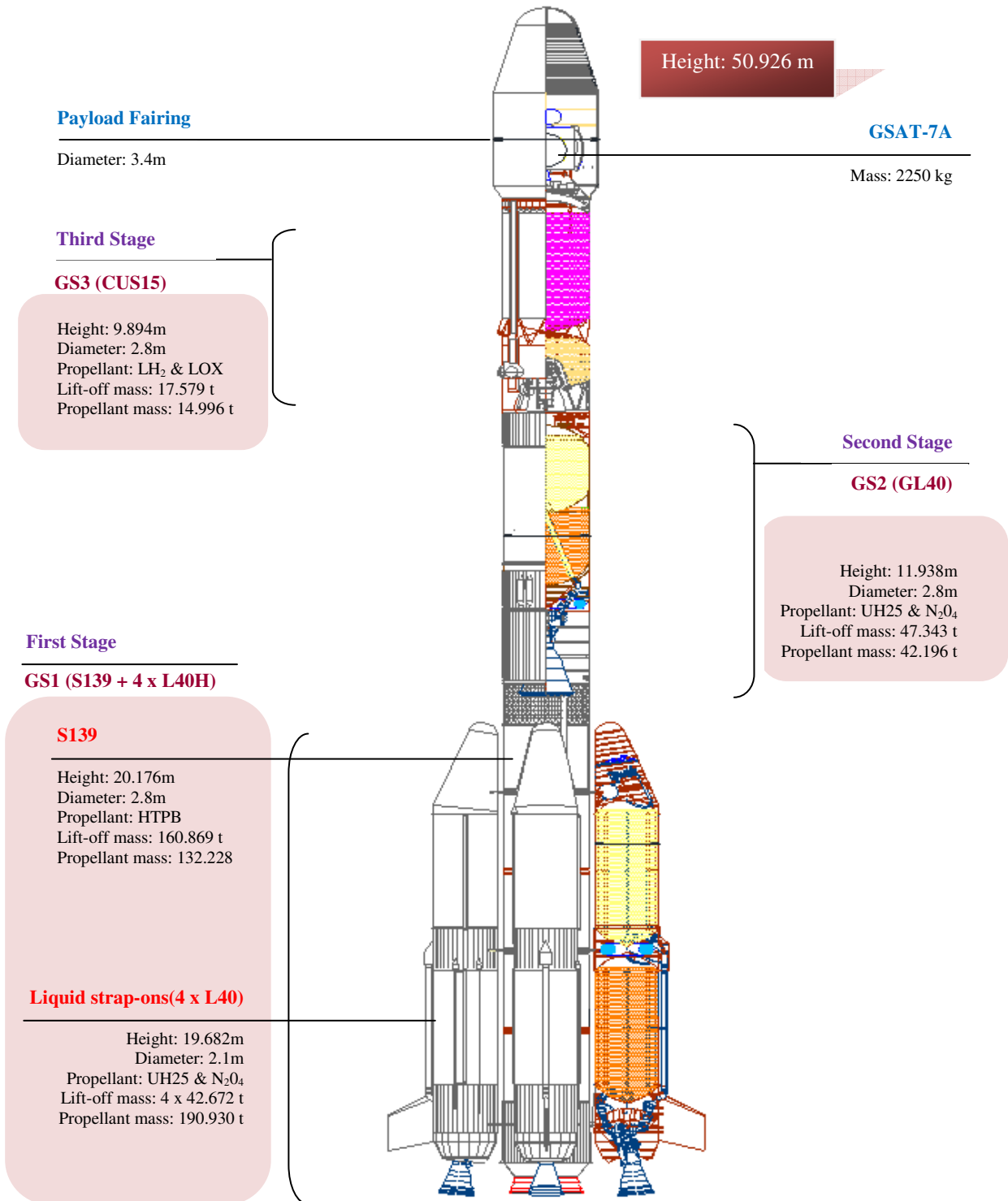

GSAT-7A

GSAT-7A is the 35th Indian Communication satellite built by ISRO. GSAT-7A Spacecraft is configured on ISRO's standard I-2000 Kg (I-2K) Bus. The bus capabilities are fully exploited with respect to accommodation, power generation, thermal management, etc. Most of the functional requirements of the communication payloads and the bus platform systems have been derived from ISRO's earlier geostationary satellites INSATs / GSATs. GSAT-7A spacecraft is configured as the payload for the GSLV MK-II flight F11.

GSAT-7A incorporates chemical propulsion system to provide an operational mission life of a minimum of 8 years. Chemical propulsion will be used for orbit raising as well as for on orbit attitude correction operations. Sufficient redundancy is built into the Spacecraft for continued service.

SALIENT FEATURES

- Lift off Mass : 2250 Kg
- Spacecraft Power : 3.3 KW
- Payload : Ku-band transponders
- Mission Life : 8 Years

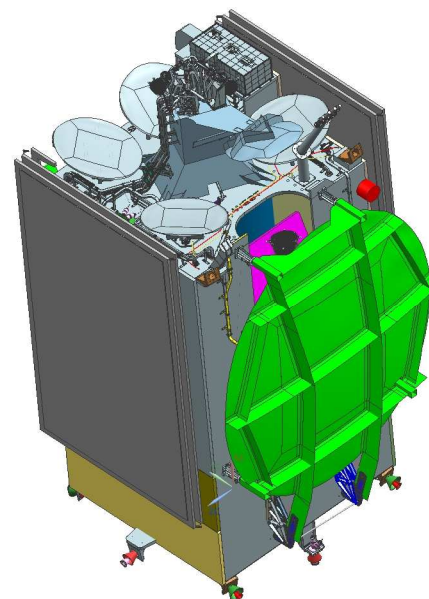

Stowed Configuration of GSAT-7A

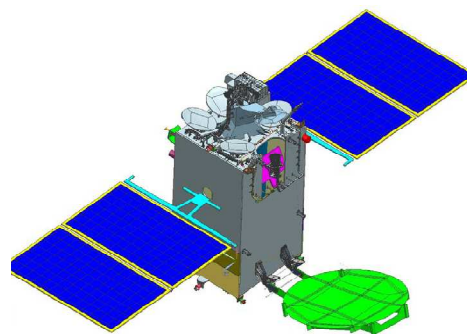

Deployed Configuration of GSAT - 7A

GLIMPSES



Liquid Strap-on (L40) being transported to Vehicle Assembly Building



Placement of Nozzle end segment of GSLV-F11 Core stage



GSLV-F11 integrated up to second stage in the vehicle assembly building



GSAT-7A being loaded into Thermovac chamber



GSAT-7A undergoing Acoustic Test