

# Technology Transfer



# Executive Summary

ISRO has transferred over 400 technologies to around 235 industries. Starting in 80s, the technology transfer program has gone from strength-to-strength, with industries engaged across various sectors and geographically covering the breadth of the nation. Broadly speaking, ISRO technology transfers can be categorized into:

- TT with the intent of buy-back: These generally include products finding application in ISRO programs. These technologies are transferred with an intent of developing a strong vendor base, so that multiple sources are available for a product. Examples include HTPB binder, UDMH, MMH, ISROSIL, 1.5 AH sealed Ag-Zn cells, Space grade Li-ion cells, etc.

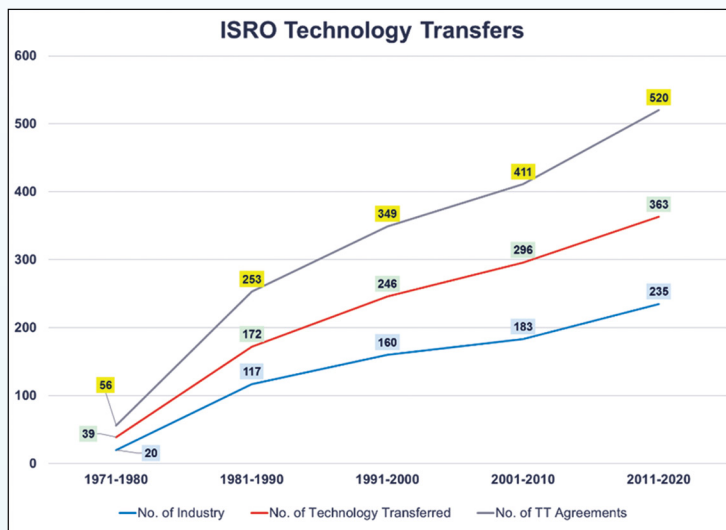

## Sector-wise Technology Transfer Distribution

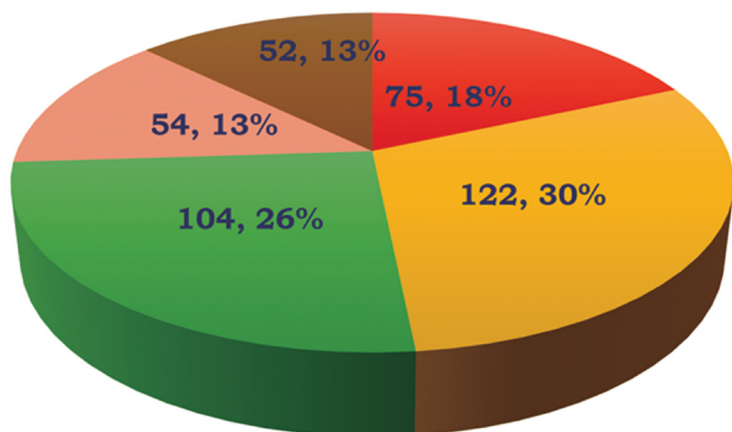

- Electronics & Computer based systems
- Chemicals & Spl materials
- Telecom Broadcasting Navigation
- Optical Instruments
- Mech/Electr-mech and others

- TT with the intent of development of Space Systems utilization and Space Applications: These products would find end-use serving organizations utilizing the space applications, such as MoES, DoT, IMD, Strategic Sectors, etc. Examples include S-band DRS, satellite telecom/ TV/Met ground systems, remote sensing utilization, NavIC applications, etc.
- TT with the intent of “non-space” applications i.e Spin-Offs: These products would mainly find industrial applications, societal benefits, academic utilization, etc. Examples include Li-ion cells for automotive sector, adhesives, pressure and temperature sensors, etc.

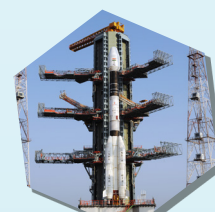
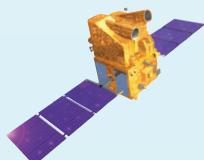
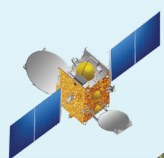

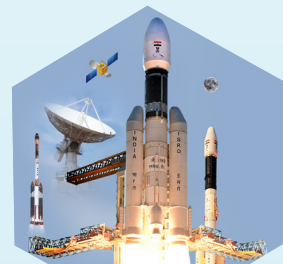
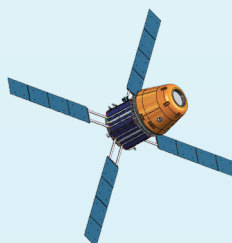
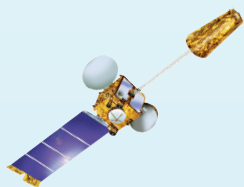

## INDUSTRIES ENGAGED STATE-WISE DISTRIBUTION

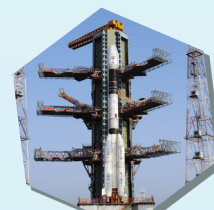
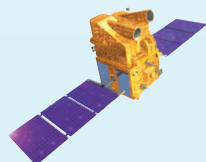
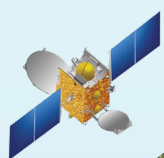
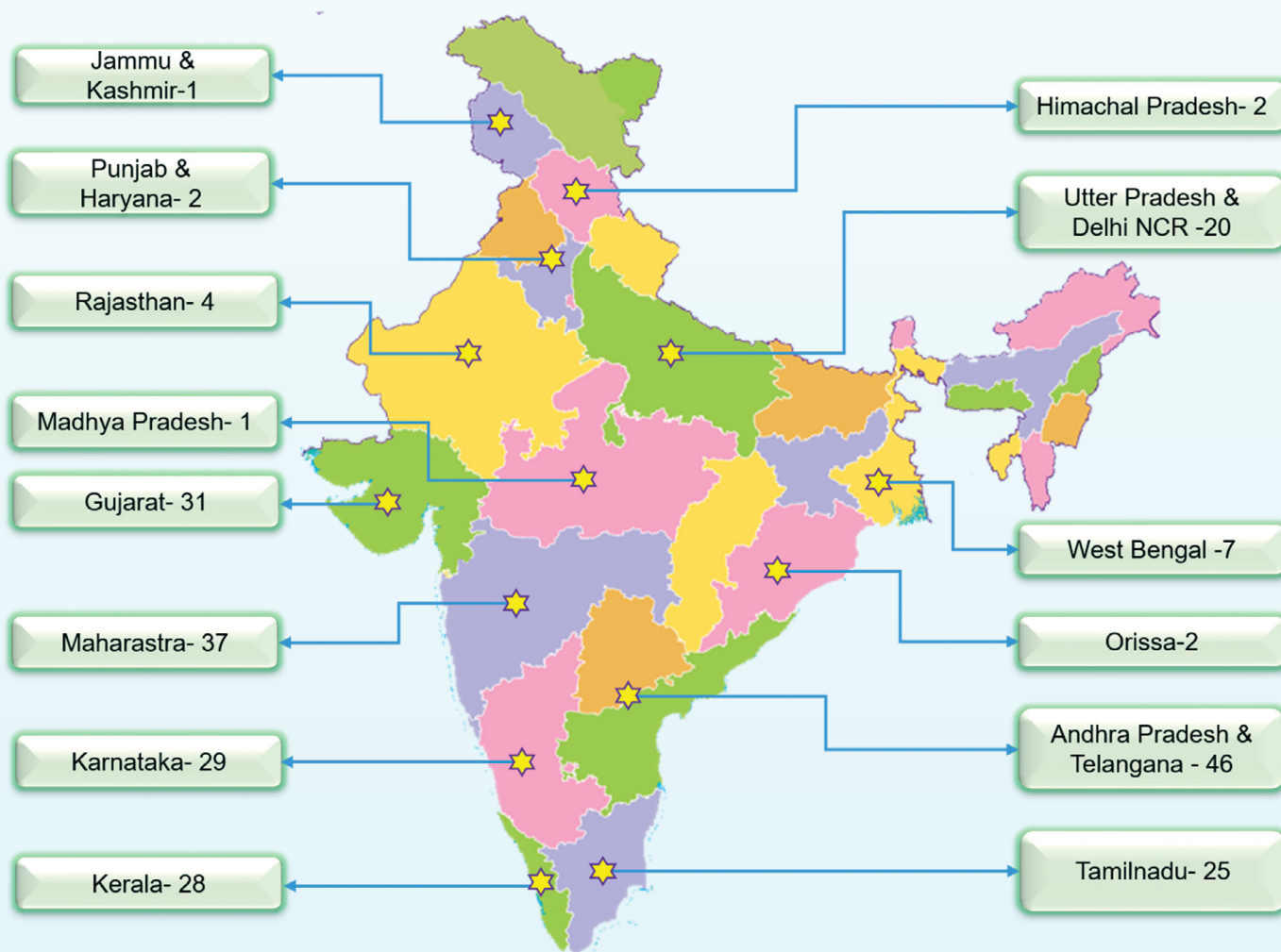

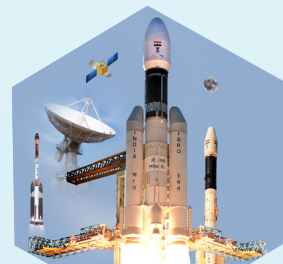
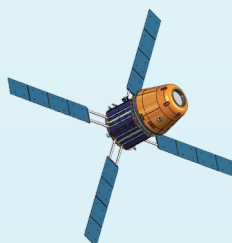
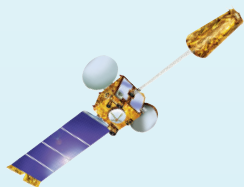

# Content

<b>1. Satellite Bus System</b>	<b>1</b>
1.1 Indian Mini Satellite -1 (IMS-1) Bus	1
<b>2. Launch Vehicle Guidance and Control Systems</b>	<b>3</b>
2.1 Ceramic Servo Accelerometer (CSA)	3
2.2 ISRO Laser Gyro (ILG)	4
<b>3. Battery Technology</b>	<b>5</b>
3.1 Lithium Ion Cells	5
<b>4. Antennas</b>	<b>7</b>
4.1. C/Ku Ortho Mode Transducer for combined C/Ku Receive Feed Systems	7
4.2. Dual feed Square Patch antenna for Reporting Terminal	9
4.3. Dual feed Square Patch antenna for Broadcast receiver	10
4.4. Multilayer Printed Antenna Technology	11
4.5. Design of Ku/C/I and S Band Cassegrain Feed	12
4.6. Patch Array Antenna for Portable Multimedia Terminal	14
4.7. X band Wide scan Active Phased Array Antenna	15
4.8. Rapidly Deployable Multi-band VSAT Terminal for Disaster Management	16
4.9. Compact L5 Band Ceramic Antenna	18
<b>5. Communication &amp; Navigation</b>	<b>19</b>
5.1. Distress Alert Transmitter (DAT-SG)	19
5.2. Personnel Tracker	20
5.3. Two Way MSS Terminal for Vessel Tracking	22
5.4. Mobile Satellite Services Terminal – Broadcast Receiver	23
5.5. Mobile Satellite Services Terminal – Portable multimedia terminal	24
5.6. Mobile Satellite Services Terminal – Reporting Terminal	25
5.7. Mobile Satellite Services Terminal – Satellite Mobile Radio	26
5.8. Two-Channel Digital Monopulse Tracking Receiver for Earth Station	27
5.9. Navic Messaging and Positioning Receiver	29
5.10. Radiosonde	31
5.11. Satellite Gateway Unit (SGU)	33

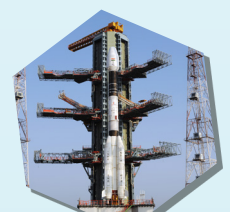
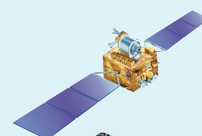
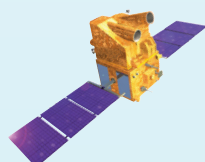
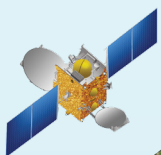

5.12. Low Cost Multi Standard Satellite Receiver (Data DTH) Technology	35
5.13. Pseudolite Based Navigation System	37
5.14. Ferrite based Wave guide Circulators and Isolators	39
5.15. High Power Circulator-Switch Assembly	41
5.16 Mini SAR	43
<b>6. RF &amp; Electronics</b>	<b>45</b>
6.1. SCPC Modem Ip Core	45
6.2. V Band Low Noise Amplifier	46
6.3. 21 NA Pressure Transducer	47
6.4. Differential Pressure Transducer (DPT)	49
6.5. HLP-85 Temperature Sensor	51
6.6. IDLV Pressure Transducer	53
6.7. MEMS based Pressure Transducer	55
6.8. PTS-84 Temperature Sensor	57
6.9. TCP-84 Temperature Sensor	58
6.10. Ultrasonic Liquid Level Sensor (USLS)	59
6.11. Burst Demodulator IP Core	60
6.12. Solid State Recorder (SSR)	61
6.13. Transmit-Receive Module	62
6.14. Power Conditioning and Processing Unit	63
6.15. L - BAND True Time Delay Phase Shifter	64
6.16. Ka Band 5W Solid State Power Amplifier	65
6.17. 15W C Band Solid State Power Amplifier	66
6.18. C band Active Radar Calibrator	67
6.19. Miniaturised High Frequency DC DC Converter	68
6.20. Supercapacitors	69
6.21. Ultrasonic Burning Rate Measurement System (UBRMS)	71
6.22. MEMS Acoustic Sensor	72
6.23. Thermal Sensors	73
6.24. TRISP (Triple Input Smart Power supply)	74
6.25. Dual Polarized, S&X Band Mono Pulse Feed for Tracking LEO Satellites	76
6.26. Integrated Tracking System for Satellite Auto Track	78
6.27. Programmable IF Matrix	79

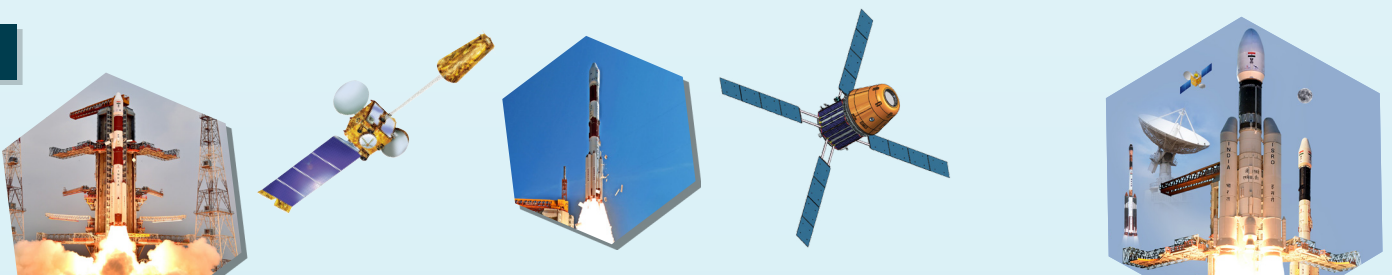



6.28. Design & Development of FPGA based Digital Demodulator	81
6.29. Low Noise Amplifiers (LNAs) and RF Amplifiers for GNSS & VHF bands	83
6.30. E-Plane Filter	85
6.31. Evanescent Mode Filters	87
6.32. Battery Charge Regulator (BCR)	89
6.33. Battery Discharge Regulator	91
6.34. Eddy Current Damper	93
6.35. Foil Heaters using Pyralux® Adhesive	95
6.36. Fine line PCB Technology for Fine-pitch surface Mount Devices	97
6.37. Rigid-flex multilayer PCB Technology	99
6.38. HMC DC-DC Converters (30W)	101
6.39. Advanced High Data Rate Modulator	103
6.40. Miniaturized methane sensor based on GRIN lens	105
6.41. Active 3D Imaging Lidar Camera	107
6.42. Highly Accelerated Thermal Shock (HATS) System for assessment of PCB via reliability	109
6.43. Electronic Safety Handheld Ohmmeter (ESHO 4.5)	111
6.44. Piezo Electric Vibration Sensor	112
6.45. Ribbon Stack Heat Flux Sensor	113
6.46. Precise TimeScale	114
<b>7. Remote Sensing</b>	<b>115</b>
7.1. Cal-Val Systems For Spaceborne Ocean Colour Sensors	115
7.2. Photosynthesis Irradiance Incubator	116
7.3. Ground Penetrating Radar (GPR)	117
7.4. Detection of Landslides from High Resolution Optical Satellite Data	119
<b>8. Software</b>	<b>121</b>
8.1. e-smart Software	121
8.2. Methods and system to control the data processing workflows in distributed environment with asynchronous message driven mechanism	123
8.3. Microwave Data Analysis Software (MIDAS)	124
<b>9. Process</b>	<b>125</b>
9.1. Lithography and Patterning on Thin Film for Hi-Rel MIC	125
9.2. Low Temperature Co-fired Ceramics (LTCC)	127

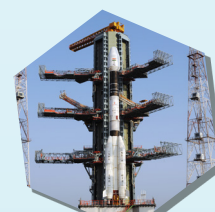
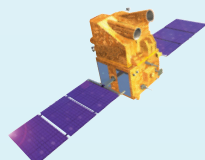
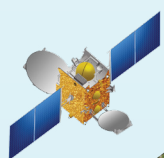

9.3. Black Anodizing On Aluminum 6061T6 & Chromating Technology	129
9.4. Smart Fire Retardant Coating	130
9.5. Gold Plating On Aluminium 6061 T6 and Kovar	132
9.6. Cr-Cu-Au metallisation for Hi-Rel MIC fabrication	133
9.7. Silver Plated Waveguides Technology	135
9.8. Thermal Control Coating Technology	136
9.9. Flameproofing Coating-Caspol	137
9.10. Corrosion Resistant Coating NRCM-204	140
9.11. Silicone polymer based thermal protection system : PC-10 TPS (Red) and (White)	141
9.12. High Emissive Silicone Coating, HESC/CSNM-29	142
9.13. FB-CVI for realisation of C-C Composite	143
9.14. Pulse Hard Anodization Process	144
9.15. Anodising on Titanium Alloys	146
9.16. Pulse Hard Anodising	147
9.17. Nanoparticle (Silver & Gold) coating on Aluminum	148
9.18. Nano-Structured Metal Deposition by electroplating method for PCB required for Space Application	150
9.19. Electroless Nickel Electroless Palladium Immersion Gold (ENEPIG) process For Printed Circuit Boards	152
9.20. Gold plated PTH / Non PTH PCBs	154
<b>10. Mechanical and Pneumatics</b>	<b>155</b>
10.1. Precision Tapping Attachment	155
10.2. Vibration Management Solutions	156
10.3. Fabrication of Waveguide Runs	157
10.4. Sit on Umbilicals for remote Fluid servicing of Launch	158
10.5. Tool For Connector Pin & Teflon Trimming	159
<b>11. OPTICS</b>	<b>161</b>
11.1. SAC Video Imaging System (SVIS)	161
11.2. Optical imaging System	162
<b>12. MATERIALS &amp; CHEMICALS</b>	<b>163</b>
12.1. Film Adhesives EFA-1753 and EFA-1752	163
12.2. EPG 2601[M]	164
12.3. ROCASIN	165

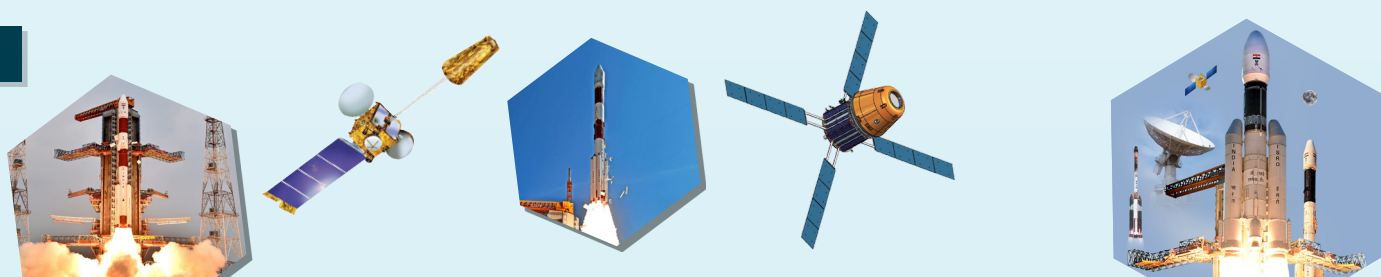

12.4. 5-Aminotetrazole Nitrate	166
12.5. BMT Ceramics	167
12.6. DK-18 Ceramics	168
12.7. High-Permittivity Ceramic (DK36) for R F Applications	169
12.8. CRYO Adhesive EPIFIL-9661	170
12.9. Matrix resin for composite application EPY PEEKTOH	171
12.10. Guanidinium Azotetrazolate (GZT)	172
12.11. Polydimethylsilane [PDMS]	173
12.12. Phenolic Resin [PF-106]	174
12.13. Phenolic Matrix Resin (PF-108)	175
12.14. RTV Silicone Single Part Adhesive, Silcem R9	176
12.15. Silica Fibres	177
12.16. Silica Granules	178
12.17. Silica Aerogel by Ambient Pressure Drying Method	179
12.18. Silica Aerogel Based Composite Sheet	180
12.19. Waterproofing Compound RWPC-03	181
12.20. Sealant EPY 2121N	182
12.21. Adbond EPP-3521	183
12.22. Umbilical Pads	184
12.23. Low Density Epdm Based Thermal Insulation	185
12.24. Coating Compound EPY 1061	186
12.25. Benzoxazine Polymer	187
12.26. Compensated Alumina (Comal) for Electronic Applications	188
12.27. Silicone Polymer Based Low Density Syntactic Foam TPS, SSF P-70	189
12.28 DK 65	190
12.29 Low Modulus Flex Seal Rubber Compound	191
12.30 NITI Based Shape Memory Alloy	192
12.31 Ceramic foam (HTFOAM-1500) by Direct Foaming Technique	193
12.32 SiC Foam Tile SICTILE-1650 by Replica Technique	194
12.33 Strontium Perchlorate	195
12.34 High Density Sintered Silicon Carbide	196

#### List of Industries

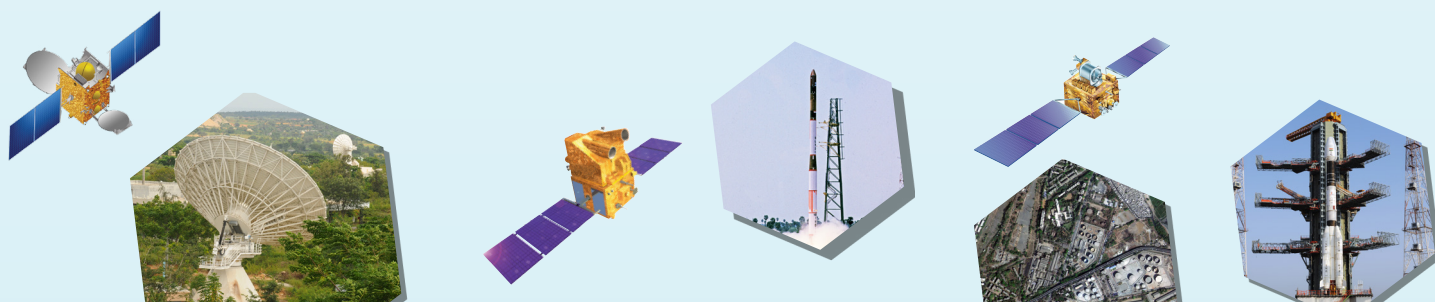

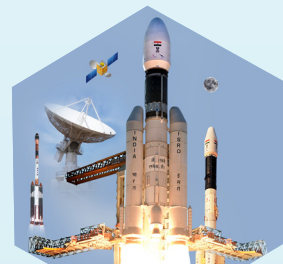
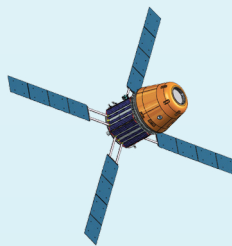
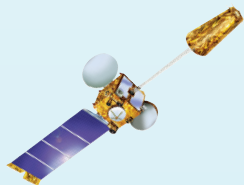

# SATELLITE BUS SYSTEM

## Indian Mini Satellite-1 (IMS-1) Bus

UR Rao Satellite Centre (URSC) of Indian Space Research Organisation (ISRO) has developed small satellite platform which would enable low cost access to space by providing dedicated platform for payloads for earth imaging, ocean and atmospheric studies, microwave remote sensing and space science missions with quick turn-around-time.

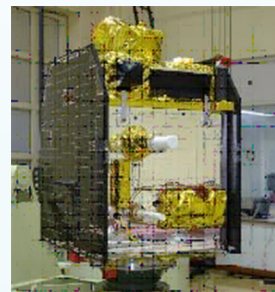

### Bus Specifications

Stability	3-axes stabilised small satellite (Bus + P/L) of 100 kg Class
Structure	Size 600 (Y) x 552 (R) x 600 (P) mm <sup>3</sup>
Pointing Accuracy	$\pm 0.1^\circ$ (3- $\sigma$ ) about all axes
Drift Rate	$\pm 7.5 \times 10^{-04}$ °/s (3- $\sigma$ ) about all axes
Nominal Mission Life	2 years
Payload Mass	30 Kg
BDH	32 Mbps
Interfaces	LVDS, 1553, Standard TM/TC Interface
Solar Panel	Solar Array consists of two wings, each having one panel of size 0.915 x 0.83 m <sup>2</sup>
Power	330 W (EOL with one string failure)
Battery	Lithium ion battery of 27.2 Ah capacity
Attitude Sensors	Magnetometer - 1 No., 4 PI Sensors, micro Star Sensors, micro-IRU
Reaction Control System	Magnetic Torquers (2nos. of 20 A-m <sup>2</sup> ) Reaction Wheels (4 Nos. of 1 Nm-s @ 8000 RPM & 0.02 Nm) Thruster of 1N-1No. Tank- 7.5 litre Volume
SSR	32 Gb
Thermal	Thermistors - 48, FTS- 16, PRTs - 10, Thermocouples - 2, On-board heaters-28

### Technology Transfer from ISRO

ISRO is willing to offer the knowhow of this technology to suitable entrepreneurs / industries in India. Capable manufacturing industries interested in acquiring this knowhow may write with details of their present activities, requirements and plans for implementation, infrastructure and technical expertise available with them, their own market assessment, if any, and plans for diversification to the address given below:

NewSpace India Limited (NSIL)

Email: [contact-nsil@isro.gov.in](mailto:contact-nsil@isro.gov.in)

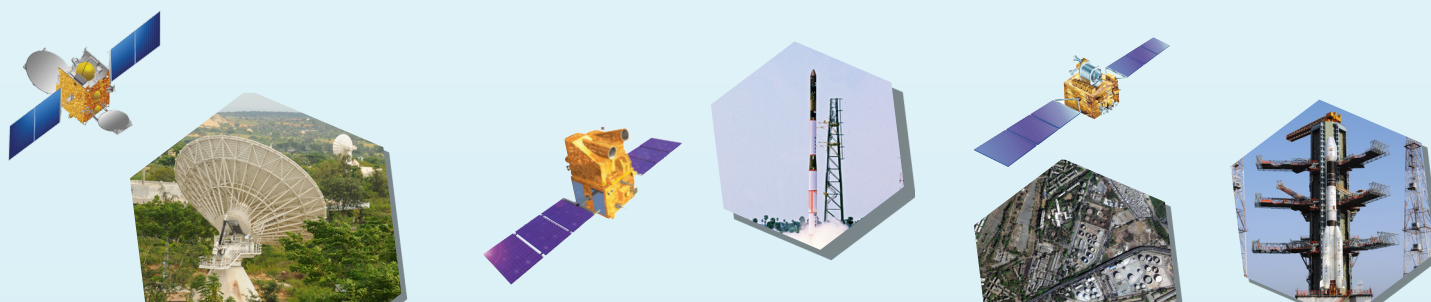

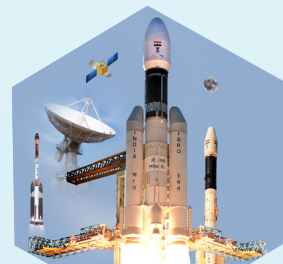
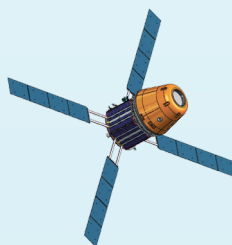
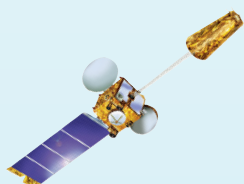

## Ceramic Servo Accelerometer (CSA)

IISU designed, developed quartz-based servo accelerometer called Ceramic Servo Accelerometer (CSA) for launch vehicle and spacecraft applications. CSA is a pendulous, forced rebalanced, analog, servo accelerometer with built in electronics. The core technology element of CSA is a monolithic flexure pendulum made of fused quartz, with special pick off coating and is indigenously developed at IISU.

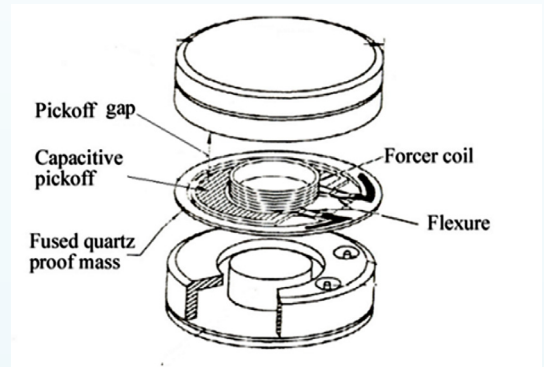

### Major Specifications

SL. No	Parameters	Specification
1	Range	$\pm 25 \text{ g}$
2	Scale Factor (SF)	$-1.25 \text{ mA / g} \pm 15\%$
3	Bias	$< \pm 30 \text{ mg}$
4	Input Axis Misalignment	$< \pm 600 \text{ arcsec}$
5	Scale Factor Short-term stability	$\leq 50 \text{ ppm}$
6	Bias Short-term stability	$\leq 50 \mu\text{g}$
7	Misalignment Short-term stability	$< 10 \text{ arc sec}$
8	Bias Warm-up to Warm-up Stability	$< 500 \mu\text{g}$
9	SF Warm-up to Warm-up stability	$< 225 \text{ ppm}$
10	Misalignment Warm-up to Warm-up Stability	$< 36 \text{ arcsec}$
11	Non-Linearity	$< \pm 30 \mu\text{g / g}^2$
12	Scale Factor Temperature Coefficient	$< \pm 150 \text{ ppm/}^\circ\text{C}$
13	Bias Temperature Coefficient	$< \pm 150 \mu\text{g/}^\circ\text{C}$
14	Band width (-3dB)	$> 300 \text{ Hz}$
15	Mass	60 gram
16	Power	0.6W (In +/- 1g Range)
17	Size	38mm dia. x 21mm height

### Technology Transfer from ISRO

ISRO is willing to offer the knowhow of this technology to suitable entrepreneurs / industries in India. Capable manufacturing industries interested in acquiring this knowhow may write with details of their present activities, requirements and plans for implementation, infrastructure and technical expertise available with them, their own market assessment, if any, and plans for diversification to the address given below:

NewSpace India Limited (NSIL)

Email: [contact-nsil@isro.gov.in](mailto:contact-nsil@isro.gov.in)

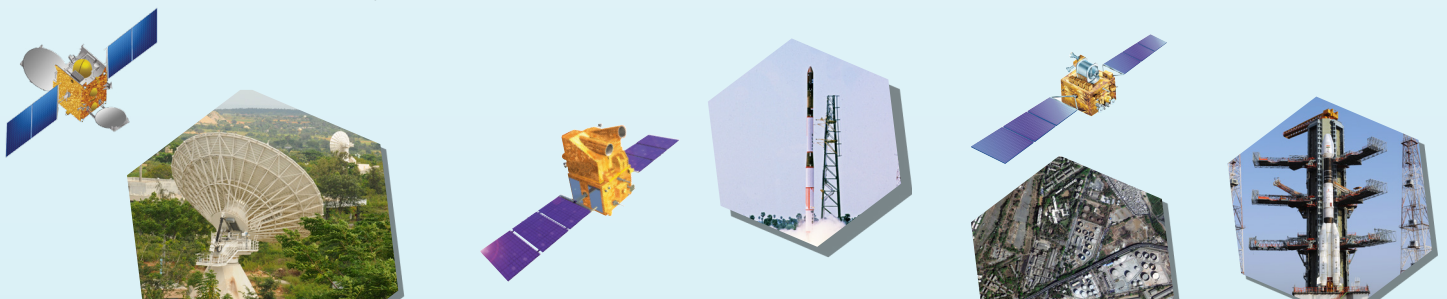

# ISRO Laser GYRO (ILG)

ISRO Inertial Systems Unit (IISU) indigenously designed, developed, qualified ring laser gyroscopes, called ISRO Laser GYRO (ILG), for the launch vehicle and spacecraft applications and inducted the same in ISRO's programs. The core technology of ILG is a RF excited, prism based square optical cavity resonator of 22 cm path length.

## Features:

- ILG is DC in – Angle out, miniature Ring Laser Gyro with 22cm path length.
- It is a Total Internal Reflection Prisms based, square cavity, active ring laser gyro.

## Major Performance Specification

1. Maximum rate : +400 deg/sec
2. Scale factor: 0.77 arc sec/pulse + 1%
3. Absolute Bias: < + 1 deg / Hr
4. Input axis misalignment: < 800 arc.sec
5. Scale factor Nonlinearity: <50ppm
6. Scale factor Asymmetry: <50ppm
7. Angle random walk: 0.02 deg/ $\sqrt{\text{hr}}$
8. Bandwidth: 17.2 + 1Hz (Software trimmable)
9. Magnetic sensitivity: 0.1 deg/hr/gauss
10. Temperature sensitivity of bias: <0.02deg/hr/ oC

## Performance Stability

- Bias stability (1 $\sigma$ ): 0.1deg/hr
- Scale factor stability(1 $\sigma$ ): <100ppm
- Misalignment stability(1 $\sigma$ ): <10 arc.sec

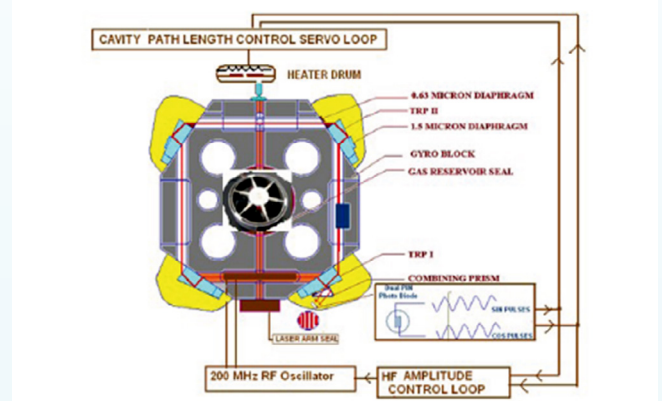

## Physical Parameters

- Size: 136 mm dia X 100 mm height
- Weight: 1.46 ± 1 kg
- Power (Nominal): 7 W

## Technology Transfer from ISRO

ISRO is willing to offer the knowhow of this technology to suitable entrepreneurs / industries in India. Capable manufacturing industries interested in acquiring this knowhow may write with details of their present activities, requirements and plans for implementation, infrastructure and technical expertise available with them, their own market assessment, if any, and plans for diversification to the address given below:

NewSpace India Limited (NSIL)

Email: [contact-nsil@isro.gov.in](mailto:contact-nsil@isro.gov.in)

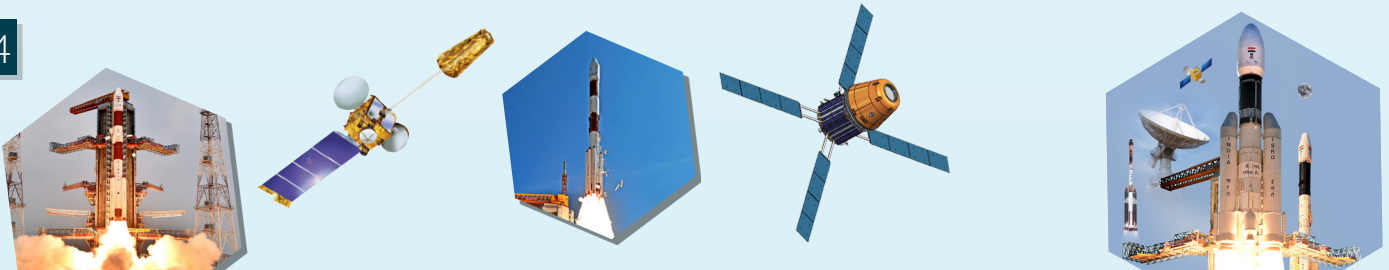



## Lithium Ion Cells

Lithium ion cells is a cost effective battery technology. It is a green alternative to fossil fuels. The technology is available for 1.5Ah, 50 Ah and 100 Ah cells.

### Salient Features

Capacity	50 Ah	100 Ah	1.5 Ah
Nominal Voltage	3.6 V		
Positive Electrode	Lithium Nickel Cobalt Aluminium Oxide		
Negative Electrode	Graphite		
Cell Case and Lid	Aluminium alloy		MS/SS
Terminal Seal	Ceramic to Metal		Plastic Compression
Separator	Polymeric Separator		
Electrolyte	Lithium salt dissolved in organic solvents		
Cell Dimensions in mm	130 x 123 x 50 (W x H x T) approx.	130 x 208 x 50 (W x H x T) approx.	18650 type
Cell Mass	~ 1.5 kg	~2.7 kg	40 g
Energy Density	≥140 Wh/kg		
Operating Temperature	10°C to 30°C		
Cycle life	>1500 cycles at 80% DOD		
Calendar life	>15 years		
Vibration	25 'g' in sine mode, 17.25 'grms' in random mode and Transportation 8 'g'		10 'g' in Sine mode, 13.5 grms in Random
Leak rate	Less than 10-8 mbar L/s		Less than 10-5 mbar L/s
Safety features	Rupture disc and Shutdown separator		Shutdown separator, PTC, CID

### Applications

Lithium ion cells find large societal applications in Electric Vehicle transport and communication areas.

### Technology Transfer from ISRO

ISRO is willing to offer the knowhow of this technology to suitable entrepreneurs / industries in India. Capable manufacturing industries interested in acquiring this knowhow may write with details of their present activities, requirements and plans for implementation, infrastructure and technical expertise available with them, their own market assessment, if any, and plans for diversification to the address given below:

NewSpace India Limited (NSIL)

Email: [contact-nsil@isro.gov.in](mailto:contact-nsil@isro.gov.in)

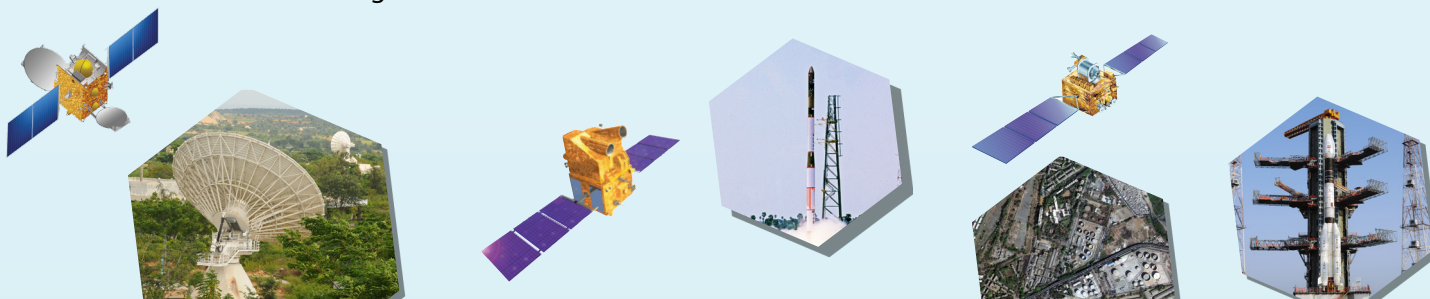

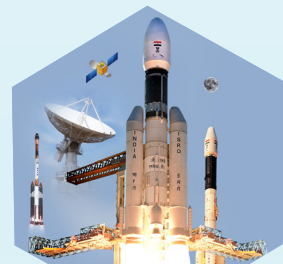
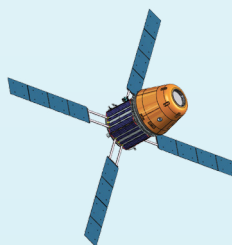
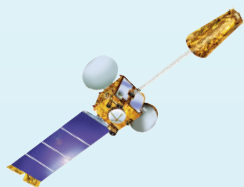

# C/Ku Ortho Mode Transducer for combined C/Ku Receive Feed Systems

Space Applications Centre has developed a C/Ku Ortho Mode Transducer for combined C/Ku receive feed systems. Such an Ortho Mode Transducer permits combination of separate C and Ku terminals into a single system thereby effecting infrastructure and cost savings.

## Technical Description

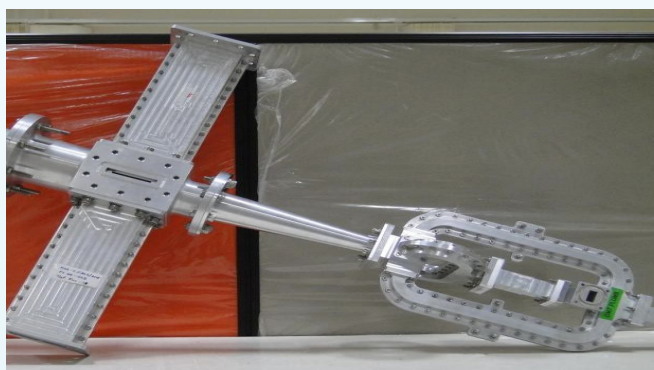

The polarization and frequency diplexing for combined C/Ku Feed system is carried out by two distinct OMTs on each for the respective bands. The Ortho Mode Transducers serves to separate the incoming signals depending on the polarization and the frequency and make them available at distinct ports for further processing. The configuration for OMTs in the respective bands differs as considerations for realizing requisite in band performance are different. The OMTs are connected by appropriate waveguide transitions.

## C Band OMT

The Cband OMT configuration comprises of a common circular waveguide with different diameters at both ends which communicates both C and Ku band signals. The signals of vertical and horizontal polarization are coupled through a pair of axial slots placed around

the periphery of the common circular waveguide at an angular interval of  $90^\circ$  between the slots. The slots are uniquely profiled for effecting coupling of the C band signals and not degrading the Ku band signals. The symmetrical configuration and unique profile of the slot ensures that no higher order modes are generated at such discontinuities which may degrade the Ku band signals. The branching waveguide network then communicate the coupled signals from each pair of slots to suitable power combining components such as Magic T, one each for the respective polarization.

## Applications

### VSAT Network

ISRO offers to transfer technology of combined C/Ku Receive feed system to industries in India with adequate experience and facilities. Enterprises interested in obtaining knowhow may write giving details of their present activities, infrastructure and facilities.

### Ku Band OMT

The Ku band OMT consist of a central circular waveguide closed at one end with four branching rectangular waveguides symmetrically arranged around it. A pair of such collinear rectangular waveguides communicates signals of the same polarization to the power combining network. The central circular waveguide consist of a unique matching element. The matching element serves to effect a good match for the incoming signals. The symmetrical configuration chosen is to circumvent that no higher order modes are generated at the common junctions. The power combining network

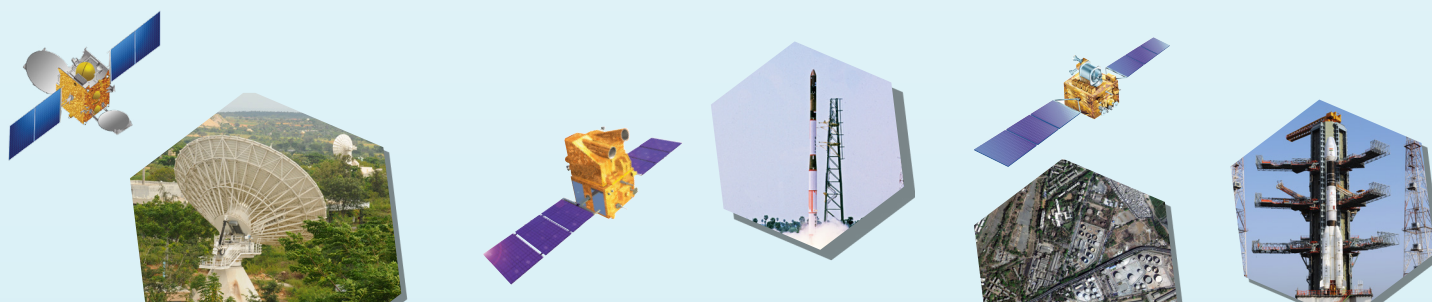

can either be effected with Magic T or simple E plane bifurcated waveguide power combiners.

## Specifications

### Frequency Bands

- C - Band : 3.7 GHz - 4.2 GHz
- Ku - Band : 10.95 GHz - 12.75 GHz

### Polarization

- Dual - Linear [ Lin- V/ Lin- H ]

### VSWR

- C -Band : 1.65 @3.7 GHz - 4.2 GHz
- Ku- Band : 1.4 @10.95 GHz - 12.75 GHz

### Insertion Loss

- C -Band : 0.5 dB [Typ] @3.7 GHz - 4.2 GHz
- Ku- Band : 0.7 dB [Typ] @10.95 GHz - 12.75 GHz

## Isolation

- C -Band Lin-V to Lin- H: 35 dB min
- C -Band to Ku-Band: 70 dB min
- Ku -Band Lin-V to Lin- H: 35 dB
- Ku-Band to C-Band: 70 dB

## Technology Transfer from ISRO

ISRO is willing to offer the knowhow of this technology to suitable entrepreneurs / industries in India. Capable manufacturing industries interested in acquiring this knowhow may write with details of their present activities, requirements and plans for implementation, infrastructure and technical expertise available with them, their own market assessment, if any, and plans for diversification to the address given below:

NewSpace India Limited (NSIL)

Email: [contact-nsil@isro.gov.in](mailto:contact-nsil@isro.gov.in)

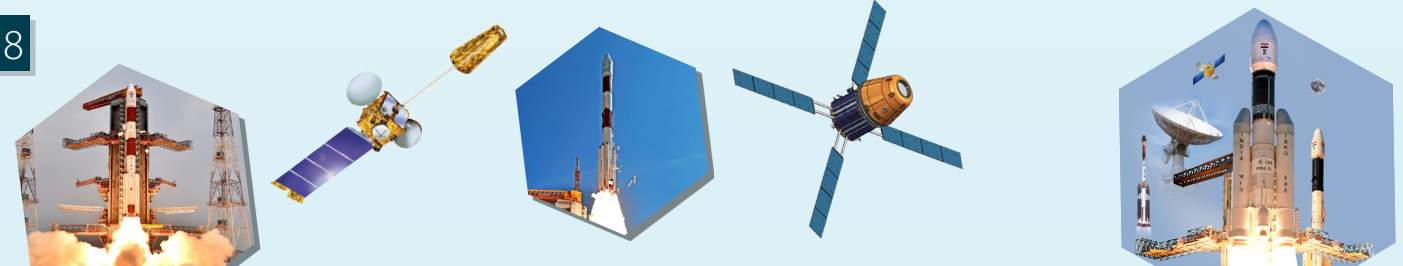

# Dual feed Square Patch antenna for Reporting Terminal

## Introduction

Designed and developed light weight compact volume profile Dual Feed Square Patch antenna for Reporting Terminal. Antenna is optimized with ABS radome & tested. Measured return loss is better than 17 dB over Transmit band. Measured gain and axial ratio is better than 2.5 dB and less than 3 dB up to theta  $\pm 45^\circ$  in all phi planes. Antenna with radome is tested in terminal from GSAT-6 Satellite.

## Developed Hardware:

## Features

S. No.	Parameters	Specifications
1.	Frequency band	2.67-2.69 GHz
2.	Return loss	Better than 17 dB
3.	Gain	2.5 dB at theta $\pm 45^\circ$ in all phi planes
4.	Axial ratio	Less than 3 dB at theta $\pm 45^\circ$ in all phi planes
5.	Size	44x44x3 mm <sup>3</sup>
6.	Weight	12 gm

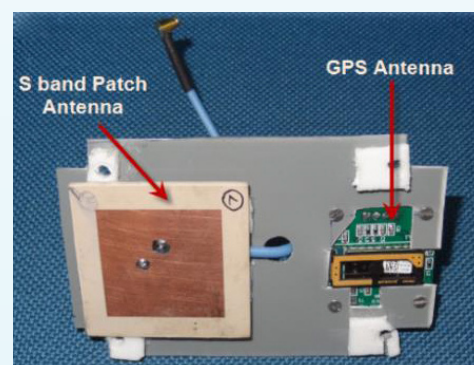

## Technology Transfer from ISRO

ISRO is willing to offer the knowhow of this technology to suitable entrepreneurs / industries in India. Capable manufacturing industries interested in acquiring this knowhow may write with details of their present activities, requirements and plans for implementation, infrastructure and technical expertise available with them, their own market assessment, if any, and plans for diversification to the address given below:

NewSpace India Limited (NSIL)

Email: [contact-nsil@isro.gov.in](mailto:contact-nsil@isro.gov.in)

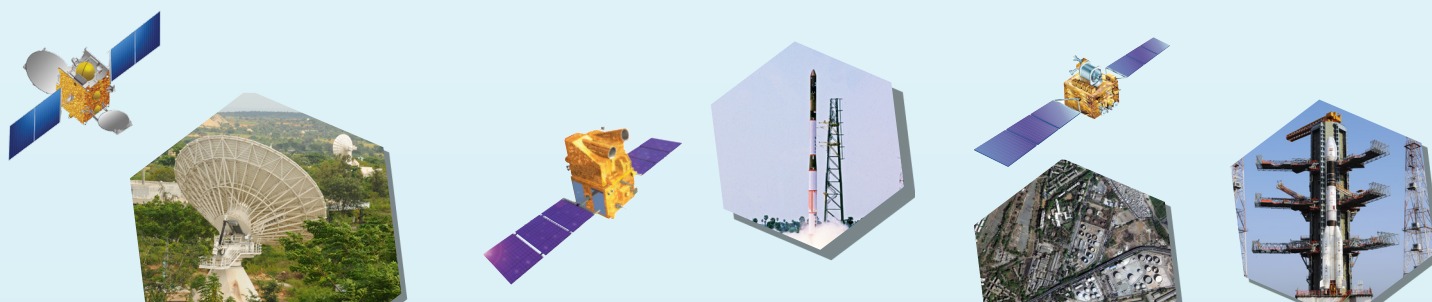

# Dual feed Square Patch antenna for Broadcast receiver

## Introduction:

Designed and developed light weight compact volume profile Dual Feed Square Patch antenna for Broadcast receiver. Antenna is optimized with ABS radome & tested. Measured return loss is better than 17 dB over receive S band. Measured gain and axial ratio is better than 2.5 dB and less than 3 dB up to  $\theta \pm 45^\circ$  in all phi planes. Antenna with radome is tested in terminal from GSAT-6 Satellite.

## Features:

S. No.	Parameters	Specifications
1.	Frequency band	2.56-2.59 GHz
2.	Return loss	Better than 17 dB
3.	Gain	2.5dB at $\theta \pm 45^\circ$ in all phi planes
4.	Axial ratio	Less than 3dB at $\theta \pm 45^\circ$ in all phi planes
5.	Size	70x70x5 mm <sup>3</sup>
6.	Weight	30 gm

## Developed Hardware:

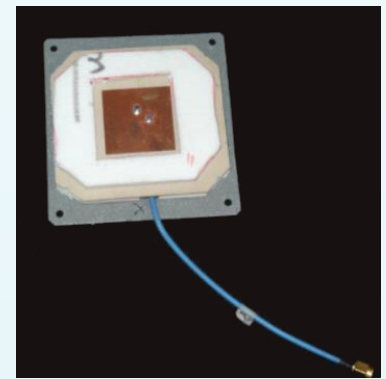

## Technology Transfer from ISRO

ISRO is willing to offer the knowhow of this technology to suitable entrepreneurs / industries in India. Capable manufacturing industries interested in acquiring this knowhow may write with details of their present activities, requirements and plans for implementation, infrastructure and technical expertise available with them, their own market assessment, if any, and plans for diversification to the address given below:

NewSpace India Limited (NSIL)  
Email: [contact-nsil@isro.gov.in](mailto:contact-nsil@isro.gov.in)

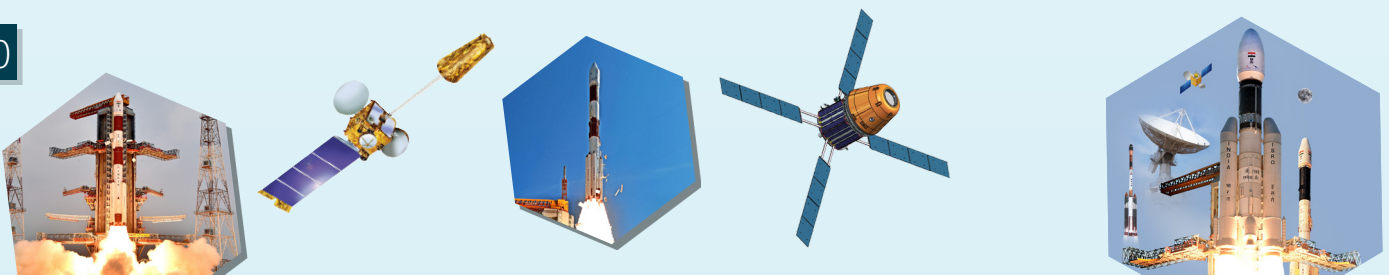

# Multilayer Printed Antenna Technology

Space Applications Centre of ISRO has developed multilayer printed antenna array technology. Salient features of the technology include light weight structure, can be made conformal to the surface, computer controlled automated fixture for aligning layers, inspection of layers and bonding of layers. There is an ever increasing demand of multilayer printed antenna from mobile communication to very sophisticated space qualified active phased array antenna systems.

The design includes the usage of new light weight & low dielectric constant material for high radiation efficiency, low surface wave propagation and low cross polar suppression. Development includes fixture capable of performing surface roughness using laser, inspection of PCB, high speed drilling, vacuum bagging for bonding all the antenna layers and vacuum gripping for pick and place.

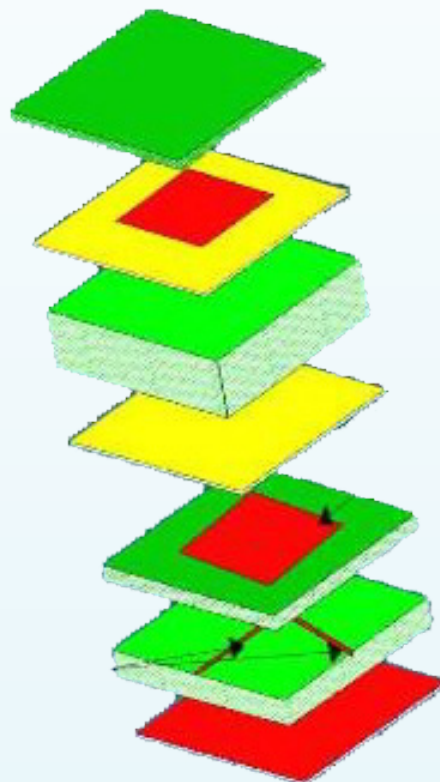

## Terminal Specifications

<b>Antenna Type</b>	: Planar
<b>Cross Polarization</b>	: Better than -30 dB
<b>Beam width and Gain</b>	: As per specifications (efficiency better than 60%)
<b>Bandwidth</b>	: Up to 40% (2.1 VSWR)
<b>Polarization</b>	: Vertical/Horizontal/Circular
<b>Size</b>	: Up to 1.2 M x 1.2 M
<b>Alignment</b>	: 20 micron
<b>Inspection</b>	: 10 micron
<b>Repeatability</b>	: 5 micron
<b>Curing Chamber</b>	: 1.3 M x 1.3 M
<b>Magnification</b>	: 50 x / 100 x
<b>Clean Room</b>	: Class 1 lac
<b>Drilling Speed</b>	: 40,000 rpm



NewSpace India Limited (NSIL)  
Email: [contact-nsil@isro.gov.in](mailto:contact-nsil@isro.gov.in)

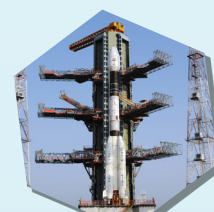
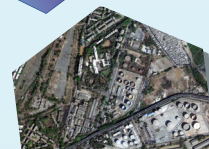
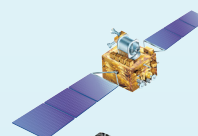
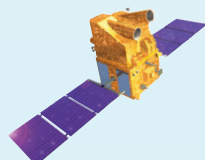
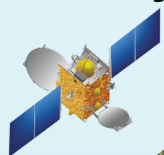

# Design Of Ku/C/L and S Band Cassegrain Feed

Space Applications Centre of ISRO has designed Ku/C/L/S band Cassegrain feed for its own payload missions. These feeds are used in earth station antenna.

Earth station antenna is used to provide communication and/or tracking, telemetry and tele-command to various in-orbit satellites. Earth station antenna for communication and/or tracking for geostationary orbit satellites typically consist of Main reflector, sub-reflector, feed system, LNA, power amplifiers, control units, network control management and its associated circuitry.

One of the most important elements in earth station antenna is feed system. Feed system is used to transmit/receive power from amplifier to sub/main reflector. It also serves to provide the desired radiation patterns to

reflectors to achieve the specified gain. Feed system combines / separates different polarizations and/or transmit/receive/tracking frequency bands. It is the feed system's insertion-loss, return-loss, tracking performance, radiation patterns, polarization and transmit/receive isolation, power handling capability – which determines the overall earth station antenna performance, governs EIRP and G/T.

So, ISRO offers to transfer technology of different feeds to industries in India with adequate experience and facilities. Enterprises interested in obtaining knowhow may write giving details of their present activities, infrastructure and facilities.

## Applications

Feed systems for Earth station Antenna

## Specifications

### Ku band Cassegrain feed for 7.2m antenna

S. No.	Item description	Specifications
1.	Operating Frequency Receive Transmit	10.70 GHz to 12.00GHz 12.75 GHz to 14.00GHz
2.	Feed Type	4 port LP rotatable frequency re-use feed. 2 ports for Tx and 2 ports for Rx.
3.	Feed Insertion Loss Receive Transmit	< 0.6dB < 0.5dB
4.	Feed VSWR at feed flange	1.3:1 Typical
5.	Power Rating	2.4 KW CW Per Port
6.	Waveguide Interface Receive Transmit	CPR 75 (square flange, four hole) CPR 75 (square flange, four hole)
7.	Isolation Tx-Tx Rx-Rx Tx-Rx XPD	> 35dB > 35dB > 85dB > 30dB

Note- Above is the specs of feed system which will be compliant to 7.2m Cassegrain antenna.

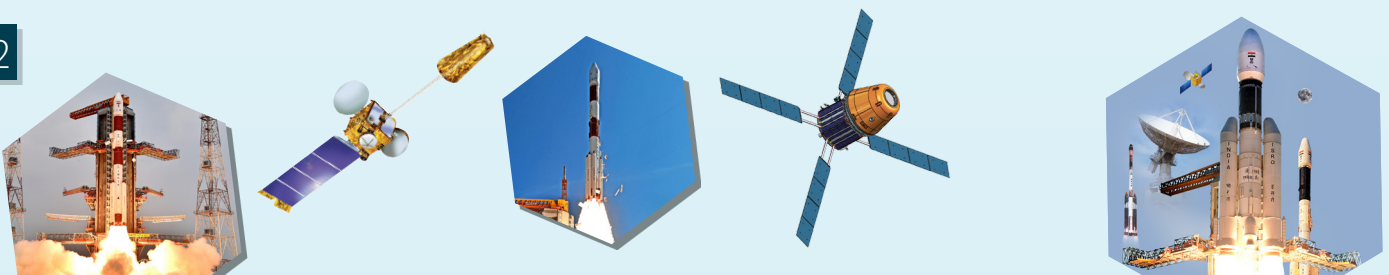



### C band LP/CP Cassegrain feed for 7.2m and 11m antenna

S. No.	Item description	Specifications
1.	Operating Frequency Receive Transmit	3.625-4.200 GHz 5.850-6.425 GHz
2.	Feed Type	4 port selectable LP/CP frequency re-use feed. 2 ports for Tx and 2 ports for Rx.
3.	Feed Insertion Loss Receive Transmit	< 0.9 dB < 0.8 dB
4.	Feed VSWR at feed flange	1.3:1 Typical
5.	Power Rating	2.0 KW CW Per Port
6.	Waveguide Interface Receive Transmit	WR 137 (for 6 GHz band) WR 229 (for 4 GHz band)
7.	Isolation Tx-Tx Rx-Rx Tx-Rx XPD	> 35 dB > 35 dB > 85 dB > 30 dB

Note- Above is the specifications of feed system which will be compliant to 7.2m and 11m Cassegrain antenna.

### L and S band Cassegrain feed for 11m antenna

S. No.	Item description	Specifications
1.	Antenna Size and Type	11 meter Cassegrain Antenna
2.	Feed type	4 port circularly polarized L & S Band receive only feed system
3.	Operating Frequency L Band S Band	1150 to 1650 MHz 2475 to 2540 MHz
4.	Gain at Feed Output	39.4 + 20 log (F/1.15) dBi (L Band Rx) 45.4 + 20 log (F/2.475) dBi (S Band Rx)
5.	G/ T at 5 deg. Elevation	17.9 dB/ deg K + 20 log (F/1.15) (L Band) 23.4 dB/ deg K + 20 log (F/2.475) (S- Band)
6.	Polarization ( Rx)	Dual Circular (RHCP/LHCP) in both the bands
7.	VSWR	1.5 : 1 Typical in both Receive Bands
8.	Axial Ratio within 1 dB BW	1.5 dB in both Receive Bands
9.	Feed Insertion Loss	<0.9 dB
10.	Rx to Rx port isolation in both bands	20 dB min.
11.	Rx Pattern	Shall conform to ITU-RS 580 <sup>-5</sup> . Typical first side lobe level shall be better than 14 dB.

Note- Above is the specifications of feed system which will be compliant to 7.2m and 11m Cassegrain antenna.

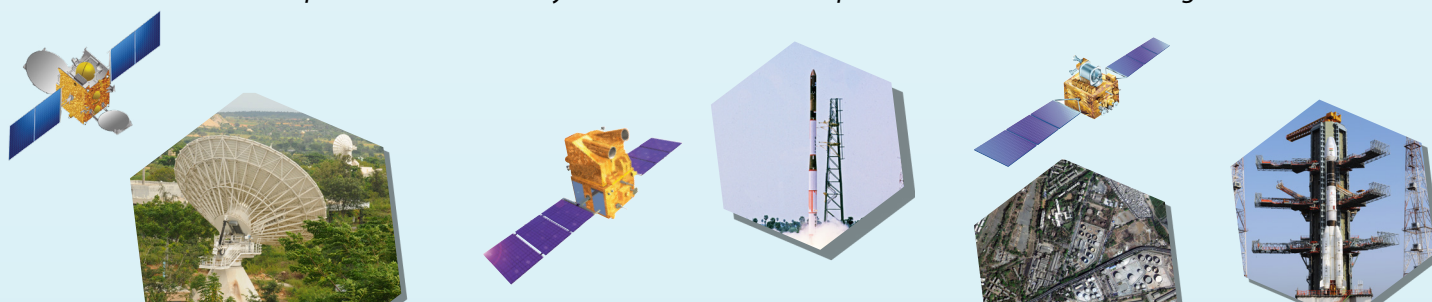

# Patch Array Antenna for Portable Multimedia Terminal

## Introduction:

Designed and developed light weight Electromagnetically coupled Stacked Patch array antenna. 8-element Dual Feed Square Patch array is used for required gain. Antenna is optimized with ABS radome & tested. Measured return loss is better than 17 dB over Transmit/Receive band. Measured gain and axial ratio is better than 15.5 dB and less than 1 dB. Antenna with radome is tested in terminal from GSAT-6 Satellite.

## Developed Hardware:

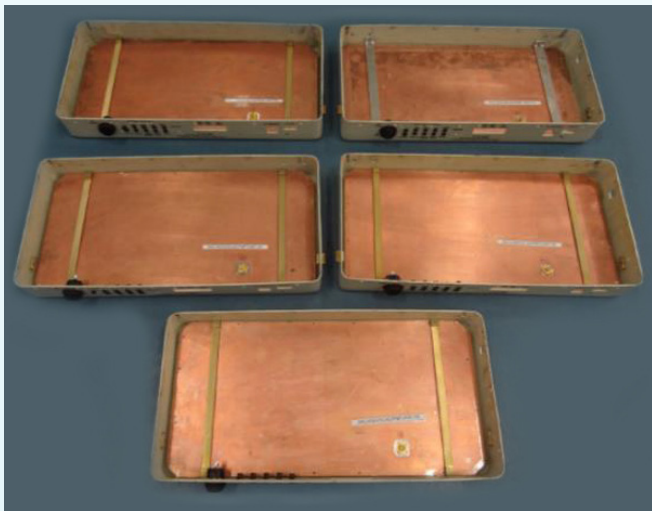

## Features:

S. No.	Parameters	Specifications
1.	Frequency band	Rx: 2.56-2.59 GHz Tx: 2.67-2.69 GHz
2.	Return loss	Better than 17 dB
3.	Gain	15.5 dB
4.	Axial ratio	Less than 3 dB
5.	Size	385x195x12 mm <sup>3</sup>
6.	Weight	280 gm

## Technology Transfer from ISRO

ISRO is willing to offer the knowhow of this technology to suitable entrepreneurs / industries in India. Capable manufacturing industries interested in acquiring this knowhow may write with details of their present activities, requirements and plans for implementation, infrastructure and technical expertise available with them, their own market assessment, if any, and plans for diversification to the address given below:

NewSpace India Limited (NSIL)  
Email: [contact-nsil@isro.gov.in](mailto:contact-nsil@isro.gov.in)



# X band Wide scan Active Phased Array Antenna

## Design Features

- Multilayer Microstrip antenna
- Suitable for wide scanning up to 60 degree
- Wide Bandwidth as compared to contemporary system
- Available simulation tools and customized code for planar antenna



Planar Array Antenna Facility



CATF Facility

## Major Specifications

- Frequency : L band to X Band
- VSWR : 1.5:1
- Gain : better than 20 dB
- Bandwidth : 5-10 %
- Polarization : Vertical, Horizontal & Dual
- Peak Power : up to 15% Duty Cycle
- Scanning Capability : Azimuth  $\pm 60^\circ$ , Elevation  $\pm 60^\circ$
- Measurement of Active Antenna Element Pattern

## Capabilities

- Multilayer Antenna development facility at SAC
- Qualified Materials for sustaining extreme temperature range
- Compact Antenna Test Facility for Accurate Pattern Measurement
- Developed & characterized wide scan active phased array antenna
- Developed 8X8 X band planar array antenna

## Applications

- Wide scanning antenna
- Tracking radar
- Phased array antenna

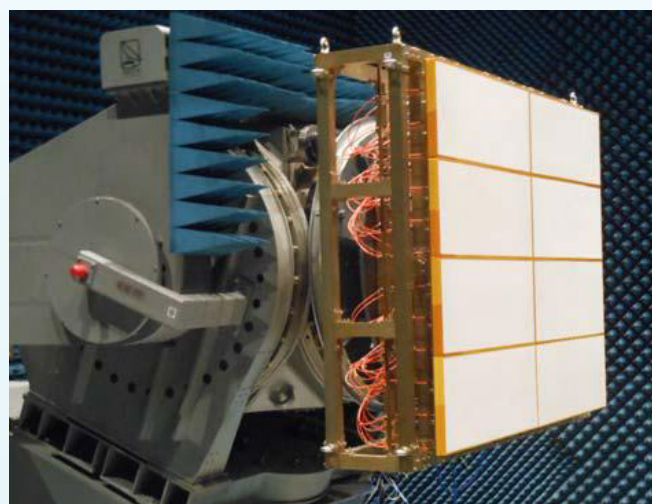

SAC designed Wide scanning Antenna at L band

## Technology Transfer from ISRO

ISRO is willing to offer the knowhow of this technology to suitable entrepreneurs / industries in India. Capable manufacturing industries interested in acquiring this knowhow may write with details of their present activities, requirements and plans for implementation, infrastructure and technical expertise available with them, their own market assessment, if any, and plans for diversification to the address given below:

NewSpace India Limited (NSIL)

Email: [contact-nsil@isro.gov.in](mailto:contact-nsil@isro.gov.in)

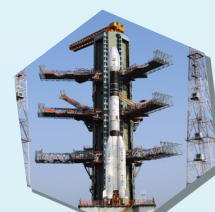
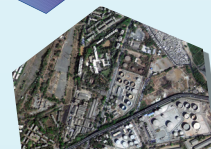
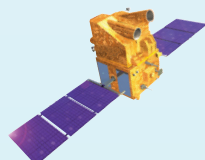
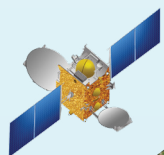

# Rapidly Deployable Multi-band VSAT Terminal for Disaster Management



minimal tools. It includes a multi-segmented glass fiber high density foam reflector, ensuring a very cost effective, light weight and excellent strength with very less deformation, even after being re-assembled hundreds of times. The m-VSAT terminal has a unique multi-band ring focus feed assembly allowing a change of frequency band in a matter of minutes simply by swapping out a quick release feed latches.

It is fully motorized and it can automatically acquire and track, even on inclined orbit satellites. Features such as fully adjustable wide spreading legs for high stability on any terrain.

For transportation it packs into its own mount which splits into two conveniently sized flight cases and one feed carrying case for transportation.

## Applications area

Highly useful in Disaster situations which quickly deployable, requiring minimal tools, light weight, easy to transport VSAT system. This system is compliant for ISRO satellite/commercial band.

A m-VSAT antenna terminal is designed specifically for any application requiring a compact, rugged, multi-band antenna which is rapidly deployable with no or

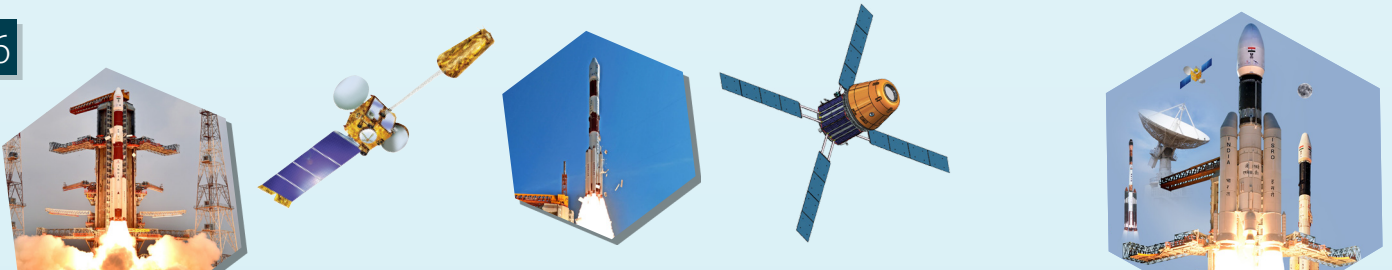

## Specifications:

S. No.	Key Specifications	
1.	Antenna Type	Circular, Axially Symmetric with Ring Focus with Central Hub plus 6 Petals
2.	Diameter	1.8 m
3.	Configuration	Gregorian Ring Focus
4.	Polarization	Linear, orthogonal transmit & receive
5.	Power Requirement	250 V AC Power Supply
6.	Temperature	-20 to +70° C- Transport & Storage -10 to +60° C- Operational
7.	Wind Rating	Operational- 60 km/h with gusts to 72 km/h Survival- 120 km/h
8.	Altitude	4500 m
9.	Humidity	100%
10.	Elevation Adjustment	0 to 90°
11.	Azimuth Adjustment	+/- 170°
12.	Polarization Adjustment	+/- 95°
13.	Packed Size	Box-1: 1 m x 1 m x 1.2 m Box-2: 1 m x 1 m x 0.5 m Box-3: 0.85 m x 0.43 m x 0.83 m
14.	Weight	Box-1: 90 kg Box-2: 30 kg Box-3: 30 kg

## Technology Transfer from ISRO

ISRO is willing to offer the knowhow of this technology to suitable entrepreneurs / industries in India. Capable manufacturing industries interested in acquiring this knowhow may write with details of their present activities, requirements and plans for implementation, infrastructure and technical expertise available with them, their own market assessment, if any, and plans for diversification to the address given below:

NewSpace India Limited (NSIL)

Email: [contact-nsil@isro.gov.in](mailto:contact-nsil@isro.gov.in)

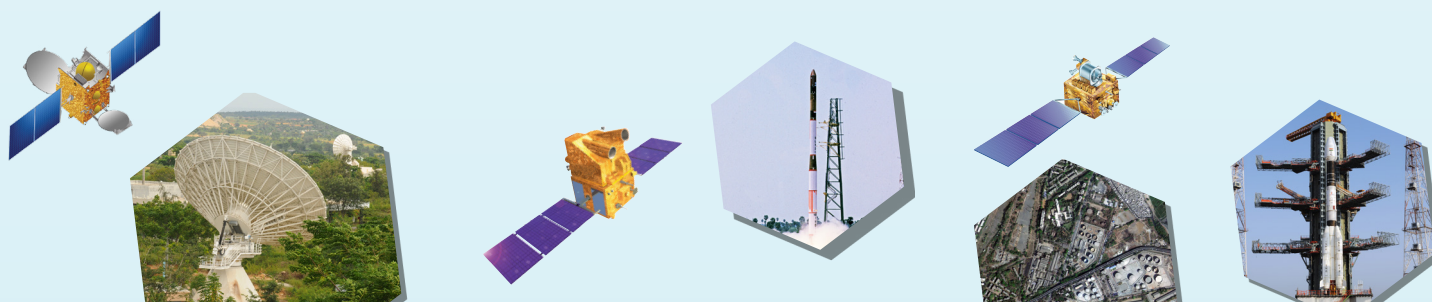

# Compact L5 Band Ceramic Antenna

Compact L5 band ceramic antenna is a compact RCP Microstrip patch antenna, designed and developed by VSSC/ISRO. This antenna uses a high dielectric constant ceramic substrate ( $\epsilon_r=65$ ) to achieve size reduction. The ceramic substrate is also indigenously developed by VSSC/ISRO and its technology is also available for transfer.

Portable navigation devices require compact antennas that can be accommodated with minimum space requirements. Compact L5 antenna can be effectively utilized in the NavIC receivers which requires a right circularly polarized (RCP) antenna operating at L5 (1176MHz) frequency with return loss less than 10dB and axial ratio less than 3dB.

## Applications area

- Can be used in navigation devices that work with NavIC/IRNSS or any other navigation system working on L5 frequency.

- Compact size of the proposed antenna makes it best suited for portable applications.

## Technology Transfer from ISRO

ISRO is willing to offer the knowhow of this technology to suitable entrepreneurs / industries in India. Capable manufacturing industries interested in acquiring this knowhow may write with details of their present activities, requirements and plans for implementation, infrastructure and technical expertise available with them, their own market assessment, if any, and plans for diversification to the address given below:

NewSpace India Limited (NSIL)  
Email: [contact-nsil@isro.gov.in](mailto:contact-nsil@isro.gov.in)

## Specifications of the antenna:

Parameter	Value	Remarks
Frequency	1176 MHz	
Band width	+5	@10 dB return loss
Peak Gain	-2 dBi	
Polarization	RCP	
Axial Ratio	<3 dB	@1176 MHz
Beam Width (3 dB)	120°	
Feed type	Coaxial	
Dimensions	25 mm x 25 mm x 4 mm	

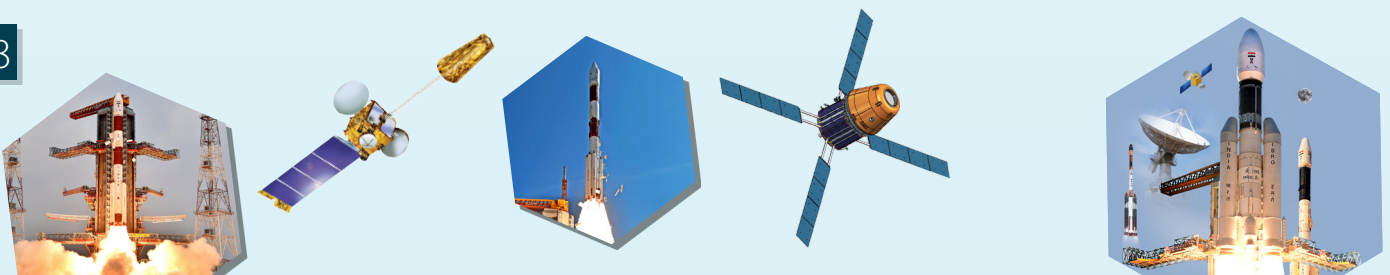

## Distress Alert Transmitter (DAT-SG)



Space Applications Centre (ISRO) has developed the Distress Alert Transmitter-Second Generation (DAT-SG) which is a UHF transmitter based on NavIC receiver module. This NavIC receiver module supports

position determination as well as broadcast messages reception called NavIC messaging service. The end users are mainly fishermen of small boats who can use this device for emergency messages reporting with position information and the unit can also help them receive useful information like Potential Fishing Zone, weather alerts etc. as supported by NavIC messaging service.

### Features

Modulation	BPSK/QPSK
Data Rate	300bps
Amp. Imbalance	±0.3 dB
Phase Imbalance	±3 deg.
Waveform	BPSK with rate 1/2 FEC
Output Power	5 W [37 dBm ± 1 dB]
Power supply	7.2V Primary Lithium Battery

### Features

- Emergency message reporting from Deep Sea to Control Station
- Processing and display of alert received at the Control Center (HUB) and dissemination of received emergency information to Maritime Rescue Coordination Centres
- Transmission of emergency position and Distress alerts

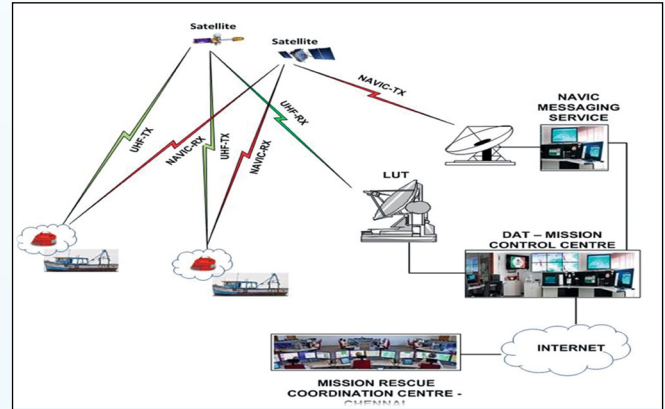

### Technology Deliverables

- Schematics, Gerber
- Hex code for firmware
- Limited Support for Development

### Present Platform details

- Microcontroller: MSP 430
- Frequency: UHF
- NavIC: SkyTraQ

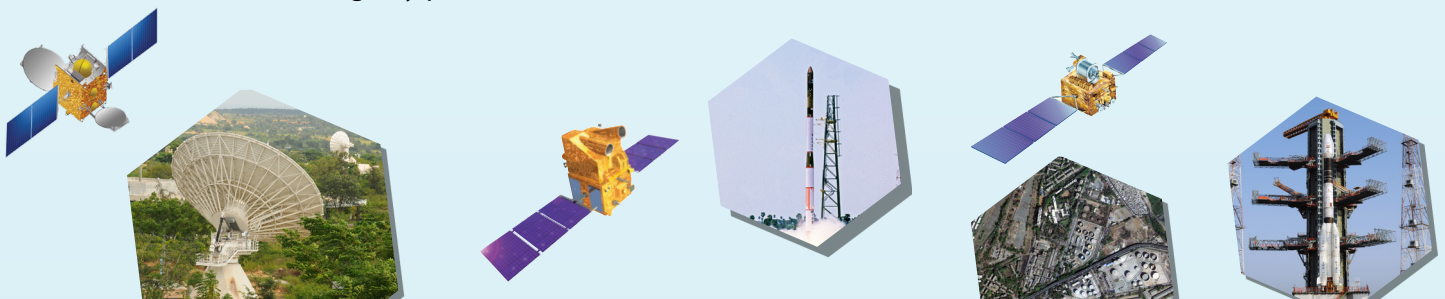
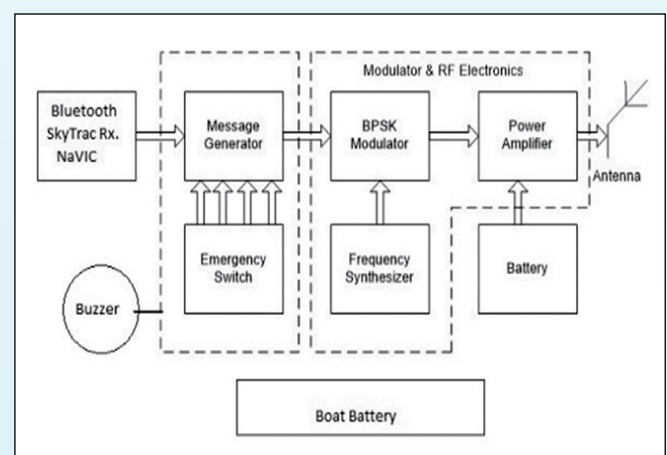

# Personnel Tracker

## Salient Feature

- Position information in TDMA / Aloha mode of operation
- Supports Small message as well as data transfer through satellite
- USB/Bluetooth user data Interface
- Handheld with battery operated
- Light weight and size within bond of 220x80x40 mm



## Specifications

- Single Patch antenna with minimum 2.5 dBi gain over  $\pm 45$  deg beam-width
- Terminal EIRP: -1 dBW with 0.5W Power Amplifier
- Burst Mode Transmission at 1.2/ 2.4 kbps with maximum payload of 80 char
- Convolution rate  $\frac{1}{2}$  coding for forward error correction
- BPSK/QPSK modulation
- Channel spacing: 10.0 KHz

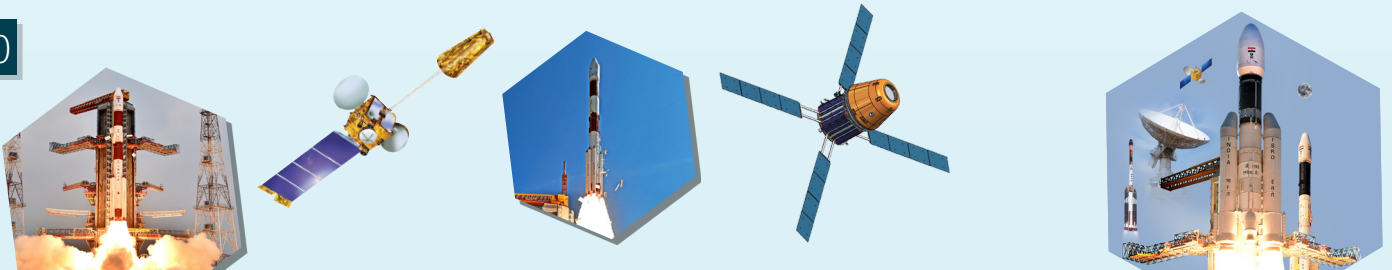



## MSS Network

- MSS Network with five user beams covering India
- User position display on GIS map in real-time
- Received user message forwarding from MSS HUB through Email, FTP etc.
- Web Based GIS support available



## Technology Transfer from ISRO

ISRO is willing to offer the knowhow of this technology to suitable entrepreneurs / industries in India. Capable manufacturing industries interested in acquiring this knowhow may write with details of their present activities, requirements and plans for implementation, infrastructure and technical expertise available with them, their own market assessment, if any, and plans for diversification to the address given below:

NewSpace India Limited (NSIL)

Email: [contact-nsil@isro.gov.in](mailto:contact-nsil@isro.gov.in)

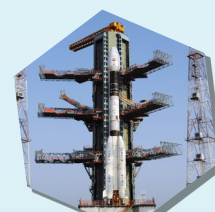
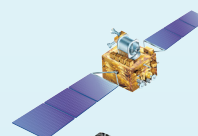
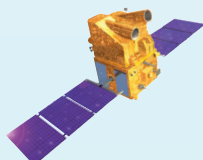
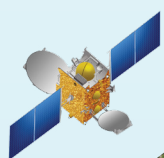

# Two Way MSS Terminal For Vessel Tracking

SAC, ISRO has developed low data rate two-way MSS terminal for tracking of small boats using in-house developed modem ASIC.



End usage: Vessel Tracking

It is developed for tracking of small boat, Other possible application be used for

- Message services
- Disaster warning dissemination
- Potential fishing zone dissemination
- Asset Tracking Services



Operating 24x7 in Indian Water



Real time tracking of Boat displayed on GIS

## Specifications

- Single patch antenna having 2.5 dBi gain over  $\pm 45$  deg beam-width
- Terminal EIRP: 3.0 dBW min.
- 250 ms time slot for reporting
- Rate  $\frac{1}{2}$  forward error correction
- QPSK Modulation
- Channel spacing 10.0 KHz

## Salient Features

- Forward Link: 9.6 kbps
- Return Link: 2.4 kbps
- Channel Access- Dynamic TDMA
- In-built GAGAN/ NavIC for position
- Bluetooth/Wi-Fi user interface
- Mast mountable
- IP65 compliance package
- Battery backup & light weight

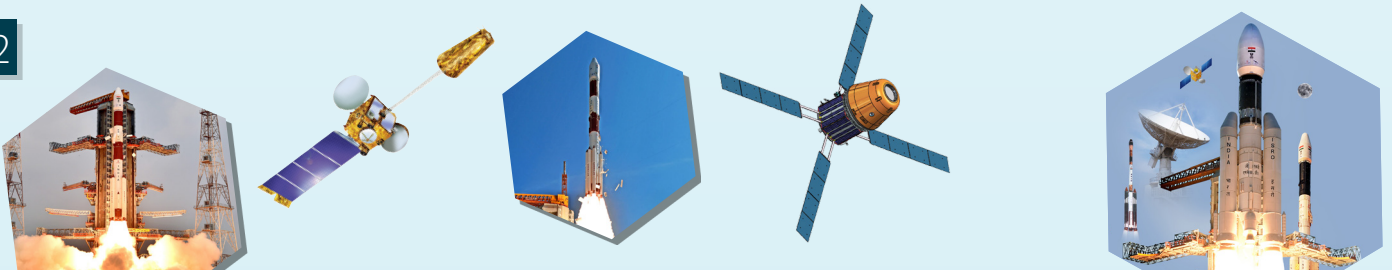
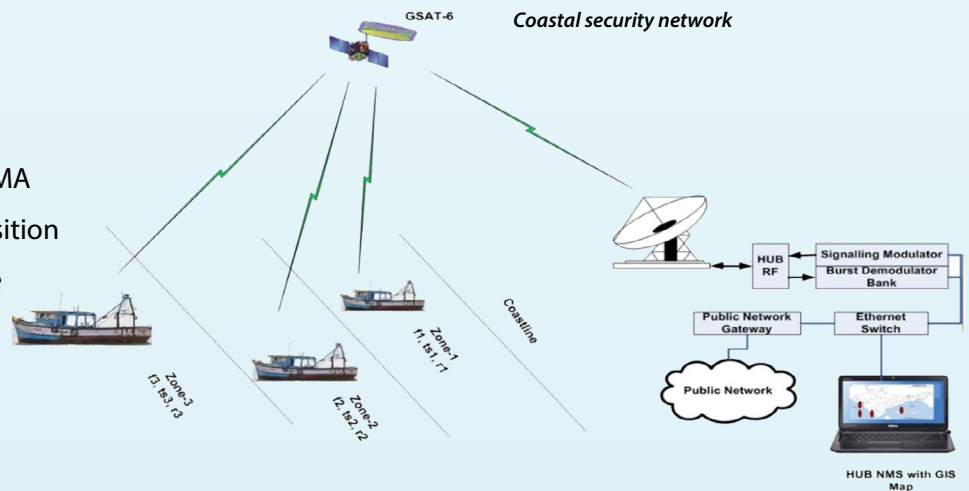

# Mobile Satellite Services Terminal

Broadcast Receiver (Handheld Receive only Terminal for multichannel reception of Audio and Video)

## Features

- Reconfigurable DVB-S Receiver: 512 Kbps to 5.5 MSPS
- USB Powered
- Supports Windows / Android OS
- Power Consumption: < 1.8W
- Weight: 180 gm (Without tablet/display)
- Broadcast Receiver for multichannel video, news, emergency message etc.

## Specifications

- Single patch antenna having 2.5 dBi gain over  $\pm 45$  deg.
- Terminal G/T: -23.0 dB/K
- DVB-S Waveform: QPSK Modulation with 1/2 Convolution + RS encoding (204,188)
- Bandwidth required: 1.5 MHz @ 1.024 Mbps
- Single carrier broadcast



## Major Applications

- Multichannel Reception of Audio, Video & Data (From Hub to terminal)
- Usable on moving vehicles

NewSpace India Limited (NSIL)  
Email: [contact-nsil@isro.gov.in](mailto:contact-nsil@isro.gov.in)

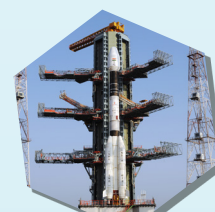
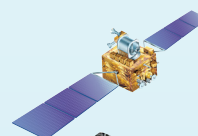
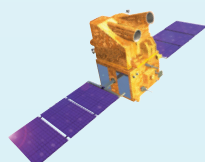
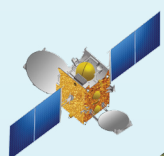

# Mobile Satellite Services Terminal

## Portable Multimedia Terminal

### Features

- Support video, voice and data communication between terminals
- Portable terminal
- QPSK Modulation
- Size: 400 x 200 x 55 mm
- Weight: 3.0 Kg



### Specifications

- 8 patch antenna having 15.5 dBi gain
- Terminal EIRP: 17.0 dBW at 2W power amplifier
- Terminal G/T: -9 dB/0K
- Data rate: 144 Kbps
- FEC: Convolution rate  $\frac{1}{2}$  / (Rate  $\frac{1}{2}$  Convolution + RS Code (112,126))
- Bandwidth required: 194.4 KHz
- Channel spacing: 200 KHz

### Major Applications

- Video-conferencing
- Two way IP based data-transfer
- Mobile Hot Spot
- IP Telephony



NewSpace India Limited (NSIL)  
Email: [contact-nsil@isro.gov.in](mailto:contact-nsil@isro.gov.in)

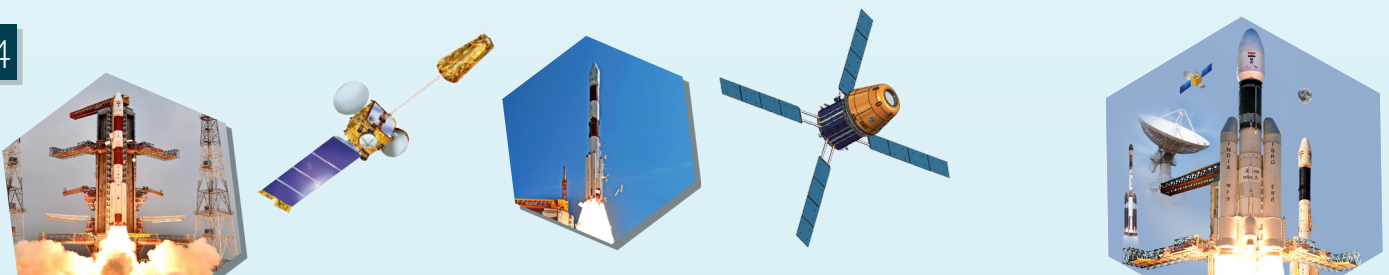

# Mobile Satellite Services Terminal

## Reporting Terminal (Handheld Data Reporting Terminal)

### Features

- Support 1.2 Kbps data rate from terminal to HUB
- Small message reporting
- In-built GPS to provide position
- RS232/USB/ Bluetooth user data interface
- Low Power & Weight
- Handheld with Size: 220 x 88 x 40 mm
- Weight: 450 gm (with battery) 160 gm (without keypad & display)

### Specifications

- Single patch antenna having 2.5 dBi gain over  $\pm 45$  deg
- Terminal EIRP: -1 dBW at 0.5W power amplifier
- Burst mode transmission rate 1.2 Kbps (Terminal to HUB)
- 1 sec. time slot to accommodate large no of terminal in single carrier
- Rate  $\frac{1}{2}$  forward error correction
- BPSK Modulation
- Band width required 3.2 KHz
- Channel spacing 10.0 KHz

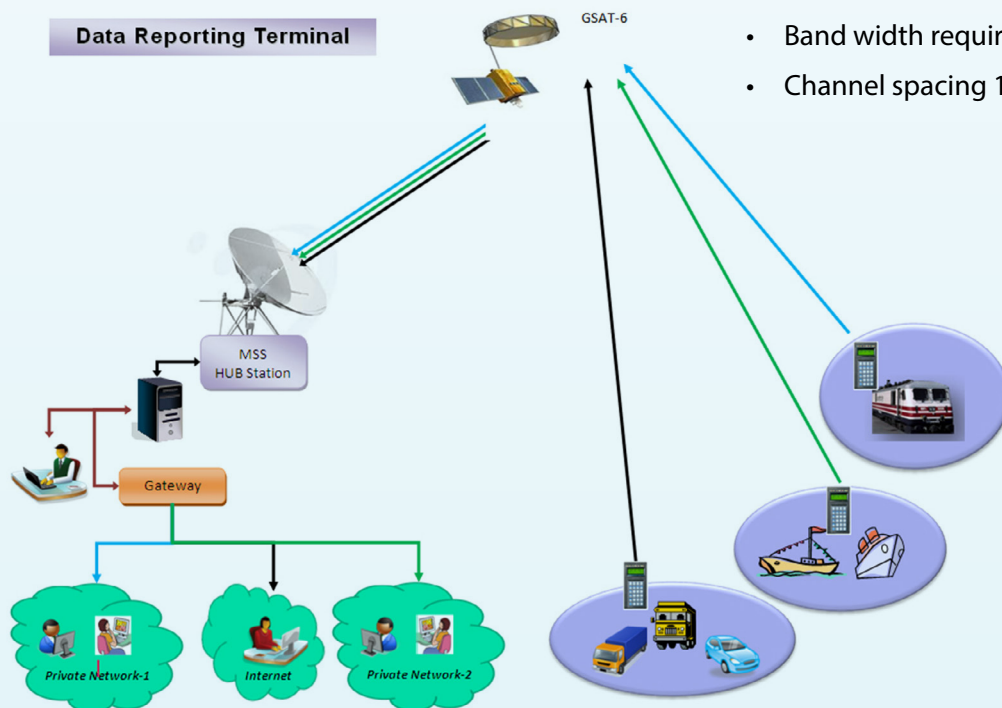

### Major Applications

- Terminal to Hub Location Reporting
- Data collection platforms
- Short Message Services
- Asset Tracking Services

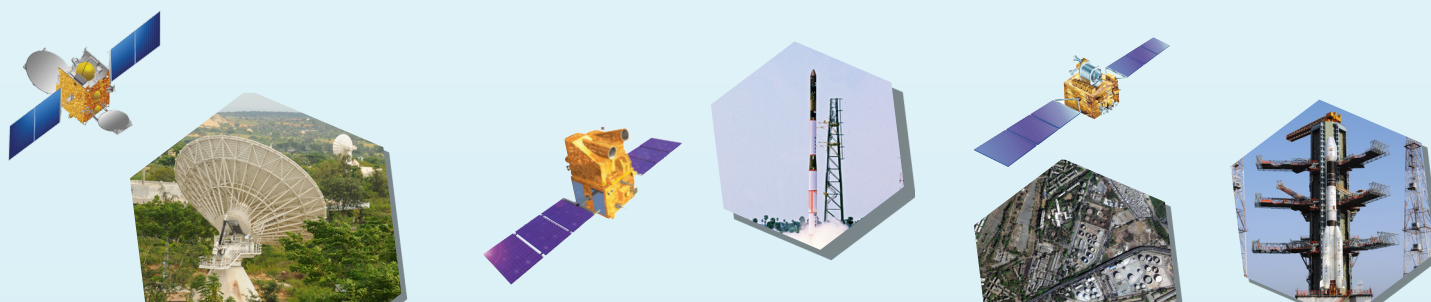

# Mobile Satellite Services Terminal

Satellite Mobile Radio (Handheld terminal for two way voice and text Message Comm.)

## Features

- Support voice communication between terminal and any other telecom network PSTN & Mobile network
- Small message communication between terminals
- Handheld with Size: 155 x 200 x 80 mm
- Weight: 1.25 Kg

## Specifications

- Antenna with 2.5 dBi gain over  $\pm 45$  deg
- Terminal EIRP: 0.5 dBW at 1 W power amplifier
- Terminal G/T: -23.0 dB/OK
- Voice compression at 2.4 Kbps gives voice quality better than 3.5 MOS
- Transmission rate: 2.7 Kbps
- Convolution Rate  $\frac{1}{2}$  forward error correction
- BPSK/QPSK Modulation
- Band width required: 3.7 KHz
- Channel spacing: 10.0 KHz

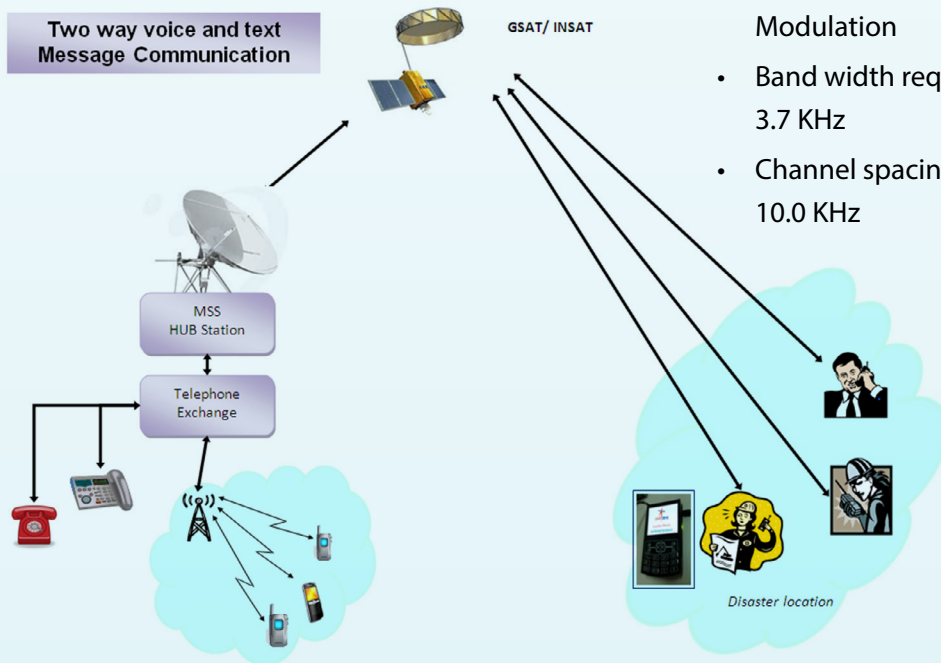

## Major Applications

- Voice communication
- Terminal to Terminal
- Terminal to PSTN/Mobile Network
- PSTN/Mobile Network to Terminal
- Small Text Message Communication

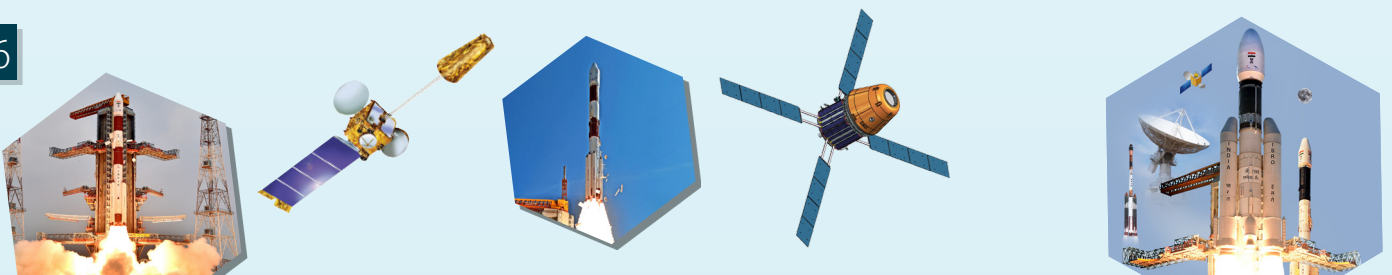

# Two-Channel Digital Monopulse Tracking Receiver for Earth Station

The two-channel digital monopulse tracking receiver for earth station is a 70-MHz monopulse tracking receiver. The monopulse tracking receiver is one of the sub-systems of monopulse antenna tracking system in large earth stations. It generates DC error

signals proportional to antenna off-pointing by processing the input IF signals in digital domain. These output error signals are used to drive the antenna in appropriate direction to correct the off-pointing error.



## Applications

- GEO Satellite Earth Station Antenna Tracking
- LEO Satellite Earth Station Antenna Tracking

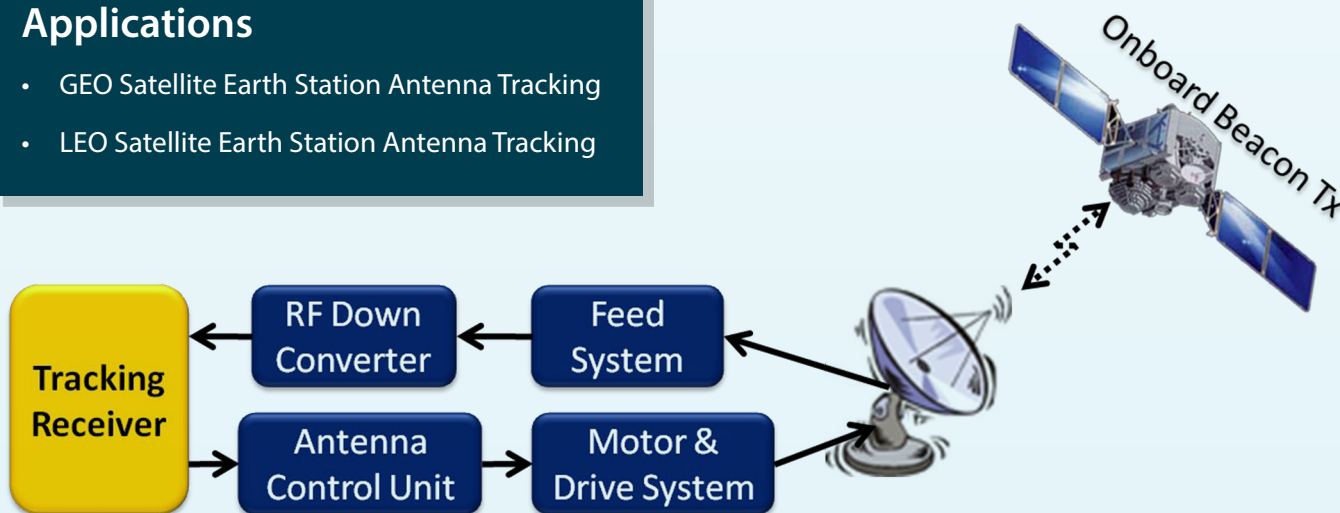

NewSpace India Limited (NSIL)  
Email: [contact-nsil@isro.gov.in](mailto:contact-nsil@isro.gov.in)

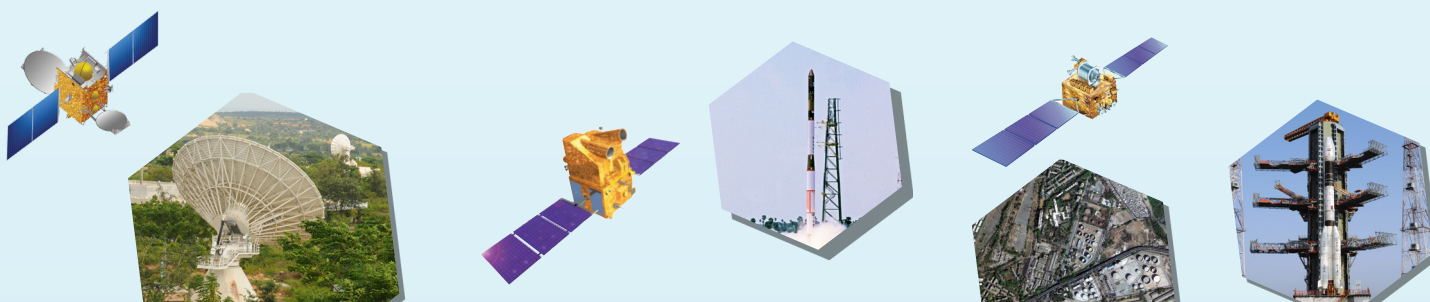

## Salient Features

- Wide Tracking Range : 70 MHz  $\pm$  250 KHz
- Wide dynamic range: 80 dB
- Selectable loop BW: 300 Hz, 1 KHz and 3 KHz
- Low input C/No threshold : 36 dBHz
- Selectable Tracking Range: 50 KHz, 150 KHz & 250 KHz
- User friendly Monitoring & Control for Local and Remote operation
- Save/ Recall configuration for different satellite
- DC Error signals output : Analog and Digital
- Low cost, flexible, easier production
- 19 inch rack mountable 3U chassis

## Testing

- POC model has been tested using Stimulus Generator in laboratory
- Completed in-system-testing at MCF, Bhopal and successfully tracked various satellites

## Technology Transfer from ISRO

ISRO is willing to offer the knowhow of this technology to suitable entrepreneurs / industries in India. Capable manufacturing industries interested in acquiring this knowhow may write with details of their present activities, requirements and plans for implementation, infrastructure and technical expertise available with them, their own market assessment, if any, and plans for diversification to the address given below:

NewSpace India Limited (NSIL)

Email: [contact-nsil@isro.gov.in](mailto:contact-nsil@isro.gov.in)

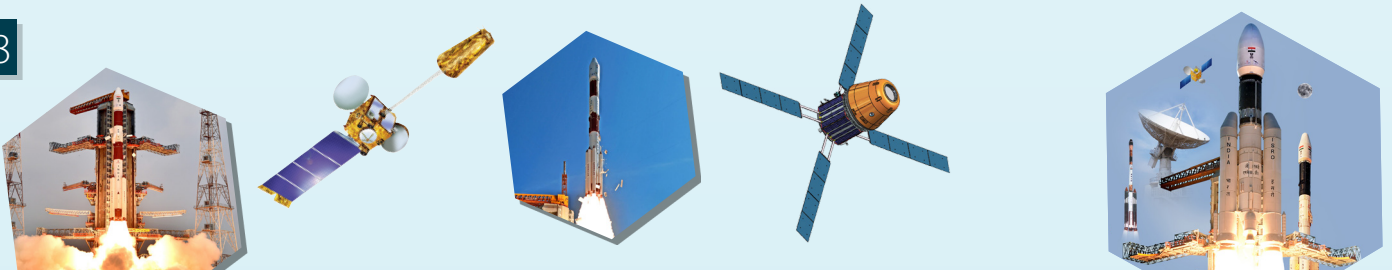



# NavIC Messaging and Positioning Receiver

## Introduction

NavIC Satellite Constellation have a wide coverage area up to 1500 km around the Indian main land. They are mainly designed for Regional Navigation Services. In addition to their primary functionality, they allow broadcasting of additional short messages. These messages can be related to alerts, forecast and directives on the occurrence of natural disasters like floods, earthquake, tsunami, cyclones, landslides etc. and dangers for the safety of life in areas with poor or no communication infrastructure. The NavIC Messaging Receiver is conceptualized and developed at Space Applications Centre (SAC), ISRO, Ahmedabad for reception and display of these messages. The receiver transmits raw data over Bluetooth link. An application running on a smart device like mobile phone or tablet having Bluetooth connectivity can decode and display the messages for users. This receiver is designed as battery operated low power device. This note describes hardware architecture and requirement for product.

## Objective

SAC has developed working prototype hardware. Product can also be used by fishermen/ marine applications in deep sea. IP67 packaging is to be designed by vendor along with battery charging option. Vendor participation is invited for production of same hardware in large numbers.

## Design

NavIC Messaging receiver has been designed to provide positioning along with messaging. NavIC module can be procured from ANTRIX Corporation Limited, Bengaluru, a commercial arm of ISRO. In

addition to the NavIC chipset, it uses ATmega328P microcontroller and HC-05 Bluetooth(BT) module. The controller provides configuration for chipset and BT module. Microcontroller acts as an interface between chipset and BT. The TPS573633DBVT LDO converts 5V to 3.3V. It is designed to draw power from battery or power bank. The power consumption of the receiver is around 100mA @ 5V. The receiver can work for about 4 days using a 10000mAh power bank. The block diagram of NavIC messaging and positioning receiver is as shown in Figure-1. Currently all the data from NavIC receiver is passed over BT to mobile which is consuming more power in both receiver and mobile. The blocks in dotted section are getting implemented as future enhancement. The idea is to save power in both mobile and device. This will be achieved by filtering out the messages in microcontroller and pass only needed messages to the mobile application. Figure 2 shows actual photograph of NavIC messaging receiver. The current size of PCB is 41mm x 46mm. The size of PCB with enhance feature is 70mm x 50mm.

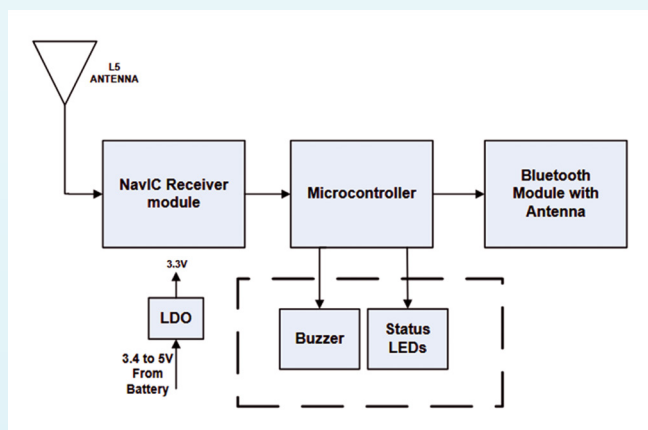

Block Diagram NavIC Messaging and Positioning Receiver

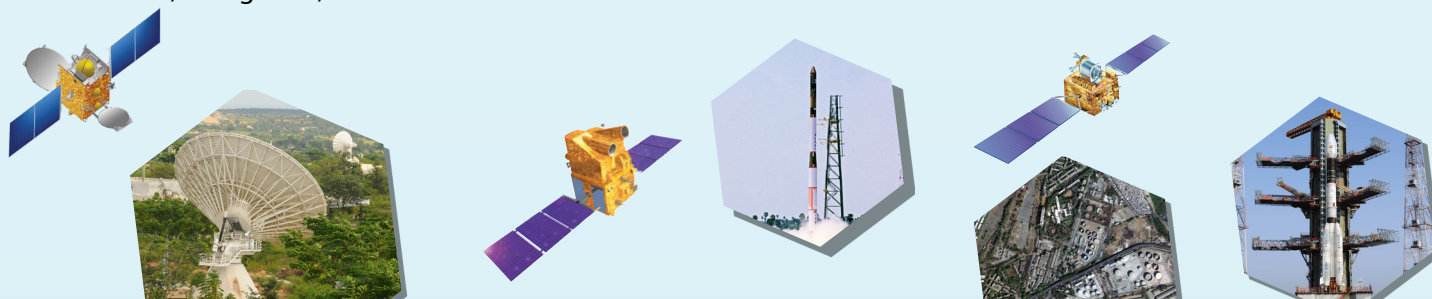

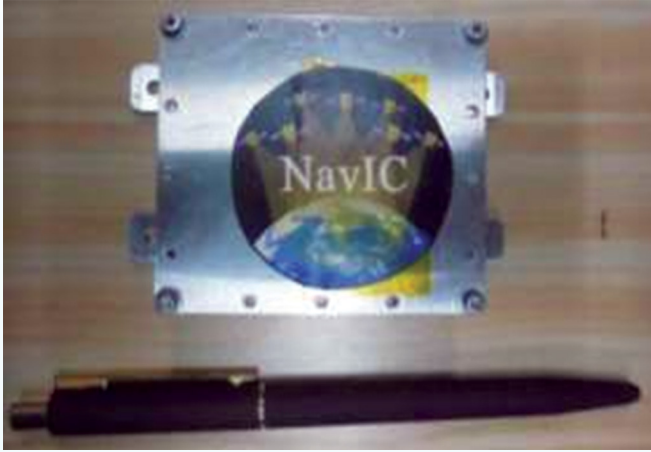

NavIC Messaging and Positioning Receiver

Above figure shows set up of receiver which has external antenna and it is drawing power from power bank. The receiver has been developed, tested, demonstrated and delivered to many users. An Android application is also developed to display the messages on Mobile phone / tablet. Messages broadcasted by INCOIS can be received using this application.

## Vendor Responsibility

Interested vendor has to fabricate the receiver PCB and design packaging including all the three components. The package has to be IP 67 compliant. The option of using power bank or some rechargeable battery is left to vendor.



NavIC Messaging and Positioning Receiver Setup with power bank and Antenna

## Technology Transfer from ISRO

ISRO is willing to offer the knowhow of this technology to suitable entrepreneurs / industries in India. Capable manufacturing industries interested in acquiring this knowhow may write with details of their present activities, requirements and plans for implementation, infrastructure and technical expertise available with them, their own market assessment, if any, and plans for diversification to the address given below:

NewSpace India Limited (NSIL)

Email: [contact-nsil@isro.gov.in](mailto:contact-nsil@isro.gov.in)

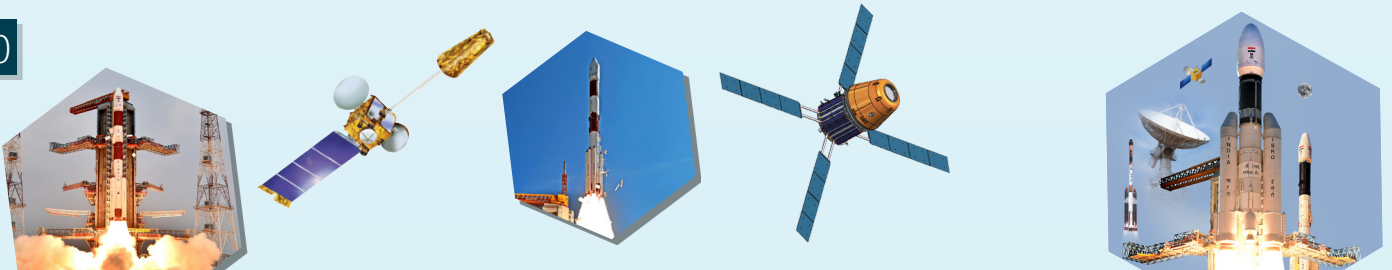

# Radiosonde

PisharotySonde system is an indigenous GPS Sonde (Radiosonde) system developed by VSSC/ISRO using commercially off the shelf components (COTS) for high quality atmospheric parameter measurement.

The Sonde system consists of the balloon borne segment referred as PisharotySonde and the ground segment referred as PisharotySonde Ground Station. PisharotySonde uses sensors for measuring the atmospheric temperature & relative humidity and GPS receiver module for acquiring the wind parameters, altitude, date and time. Pressure information can be derived from the height and temperature information using software. Sensor and GPS data are processed and transmitted to

ground station. PisharotySonde Ground Station consists of the Antenna Assembly & LNB, Receiver and Data Processing & Display unit. Sonde system incorporates the software for solar radiation correction on temperature measurement.

The Sonde system also generates the WMO specified 'temp' messages for reporting the data. This indigenous low cost system is compact and light weight (125 grams). PisharotySonde system is validated by comparison ascents with various internationally available Sonde systems and the performance is confirmed. The system performance is evaluated independently by IMD and cleared for meteorological applications. More than 12000 Sondes have been already realized by ISRO.



Fig. Sonde on ascent

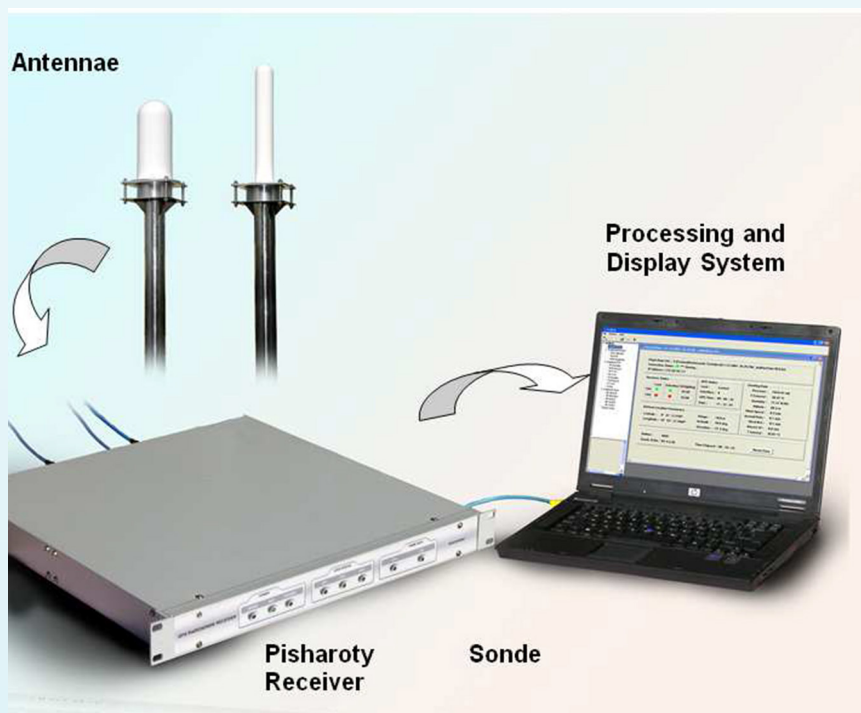
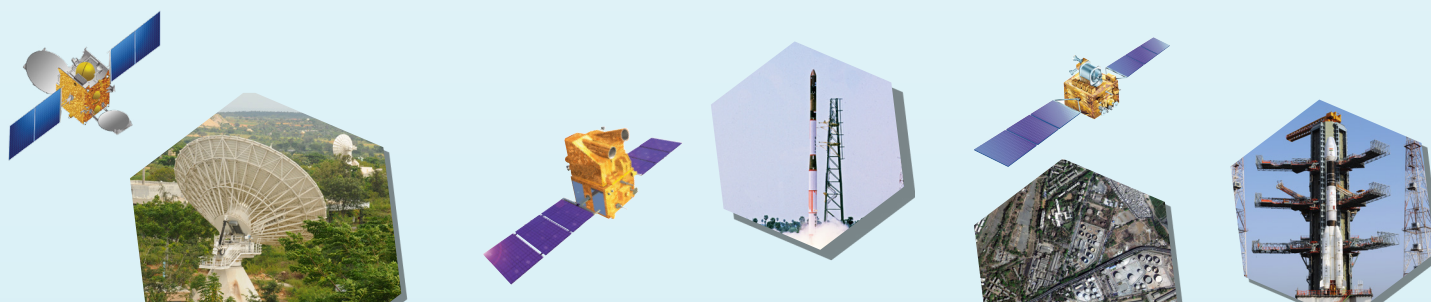

Fig. Sonde Ground Station



## Specifications of PisharotySonde System

### A. Sonde

- Frequency : 400 to 406 MHz (user programmable)
- Power : 17 dBm (50 mW)
- Size : 12 cm x 11.5 cm x 9 cm
- Weight : 125 gm
- Battery : up to 4 hours operation

### B. Ground Station Receiver

- Frequency : 400 to 406 MHz (user programmable)
- Sensitivity : -117 dBm @  $1 \times 10^{-3}$  BER
- Connectivity : Ethernet
- Power Supply : 220-230 V AC, 50 Hz
- Battery Backup : 6 Hours
- Size : 47.5 cm x 23.5 cm x 4.5 cm (19" rack mountable)

Description	Range	Accuracy	Resolution	Response time
Pressure*	0 to 1030 hPa	$\pm 1.4$ hPa ( $>100$ hPa) $\pm 0.5$ hPa ( $\leq 100$ hPa)	0.01hPa	NA
Temperature	-90 to 60 °C	$\pm 1$ °C	0.1°C	1s
Relative Humidity	0 to 100%	$\pm 5$ %	0.1%	5s
Velocity range	0 to 500 m/s	0.1 m/s	0.01 m/s	NA

\*Pressure is derived from altitude

## Applications

The PisharotySonde System is used by scientists for boundary layer studies and upper atmospheric observations. PisharotySonde system is used by Space Physics Laboratory (SPL) VSSC, MET TERLS VSSC, MET/SHAR, SAC, NESAC, NRSC and various universities for atmospheric studies. Data from the System is used regularly to support ISRO's satellite launches. The System is identified as part of network of weather stations for thunderstorm observation in SAARC countries. Huge market demand also exist in atmospheric measurements by IMD, defence and academic institutions.

## Technology Transfer from ISRO

ISRO is willing to offer the knowhow of this technology to suitable entrepreneurs / industries in India. Capable manufacturing industries interested in acquiring this knowhow may write with details of their present activities, requirements and plans for implementation, infrastructure and technical expertise available with them, their own market assessment, if any, and plans for diversification to the address given below:

NewSpace India Limited (NSIL)

Email: [contact-nsil@isro.gov.in](mailto:contact-nsil@isro.gov.in)

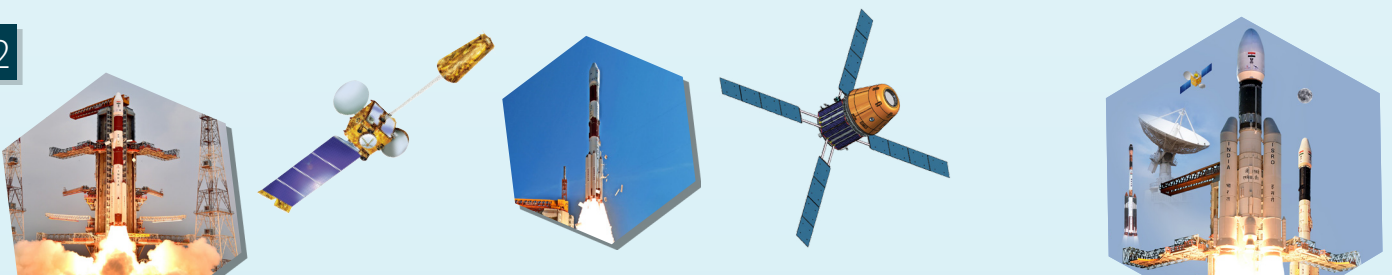

# Satellite Gateway Unit (SGU)

The Satellite Gateway Unit (SGU) is useful to interface two different types of network – LAN and synchronous serial communication over satellite. The SGU is a low cost solution to transport IP/Ethernet frame over satellite network. It supports both unicast and multicast mode of communication. It can handle satellite channel signaling and conferencing call signalling that is useful in many SATCOM applications. All commercially available gadgets for packet based data communication like – VoIP, Video phone etc., are having LAN interface, to introduce those equipment into satellite network, SGU required that efficiently

converts the IP data format into a synchronous HDCL format and vice versa. It is having proper routing/ filtering mechanism to restrict unwanted traffic flows into the satellite link.

Satellite Gateway unit converts data between RS-422 to Ethernet. The unit is designed to work with internal clock or external clock selectable via jumper selection. The unit consists of total 8 communication channels and 1 control channel. The control channel is used to individually reset the communication channel via Ethernet port or via RS 485 port.



Front panel of 9-channel SGU



Back panel of 9-channel SGU

## Applications area

- MSS services Hub base band systems as a gateway between synchronous serial interface of satellite systems and IP based hub baseband systems
- VOIP phone over satellite network

## Specifications:

No. of Communications Channels	: 8, can be configured independently
No. of M&C port/channel	: 1, can be configured independently
No of Processors per channels/m&c	: 1, RABBIT 6710 (total 9 processors)
Ethernet ports at Front panel per channel	: 1, 10/100 Ethernet RJ45 with Link And Activity Indicator
Ethernet Protocols supported	: TCP, IP, UDP, RTP, HTTP
Communication Interface	: RS422 synchronous (Tx data, Tx Clock, Rx Data, Rx clock)
Input Data Rate	: 2.4 Kbps to 384Kbps or higher
Clock selection	: Internal, External, Selectable
Communication interface protocols	: HDLC, Bi-sync, selectable

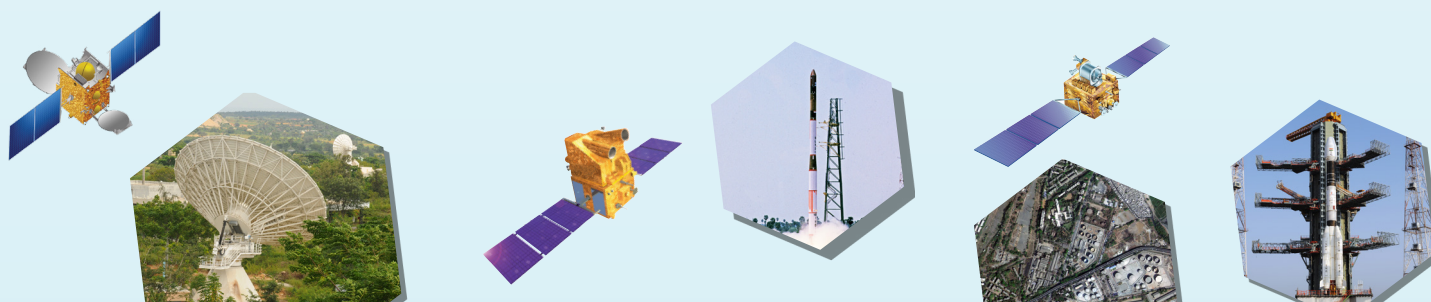

Communication Interface Connectors Back panel	: 9 PIN D type –male per channel
Communication LEDS	: 3 nos (RXD, TXD, link) per channel Front Panel
Operating System	: Rabbit Bios
M&C interface	: RS485 and RS232, selectable
M&C Interface connectors- Back Panel	: 9 PIN D type -female
M&C LEDS- Front Plate	: 3 nos. (RXD, TXD& link)
Push type master reset switch	: On Front Panel
Enclosure	: Standard 19",standard 1U size,
Rack Mountable Cooling Fan	: 2, one as inlet and second as outlet
Power supply with EMI/RFI filter	: 230VAC with standard 3 pin Connector on Rear panel with Power supply cable
Power on/off switch – front panel	: Yes
Power indicator-front panel	: Yes
Temperature range	: 0 to +50 deg C
Humidity	: 5% to 95%, non-condensing

SGU is being used as a part of operational GSAT-6 MSS services Hub base band system for portable multimedia services and satellite Mobile Radio services (two way voice communication) at DES and at AES.

## Technology Transfer from ISRO

ISRO is willing to offer the knowhow of this technology to suitable entrepreneurs / industries in India. Capable manufacturing industries interested in acquiring this knowhow may write with details of their present activities, requirements and plans for implementation, infrastructure and technical expertise available with them, their own market assessment, if any, and plans for diversification to the address given below:

NewSpace India Limited (NSIL)

Email: [contact-nsil@isro.gov.in](mailto:contact-nsil@isro.gov.in)

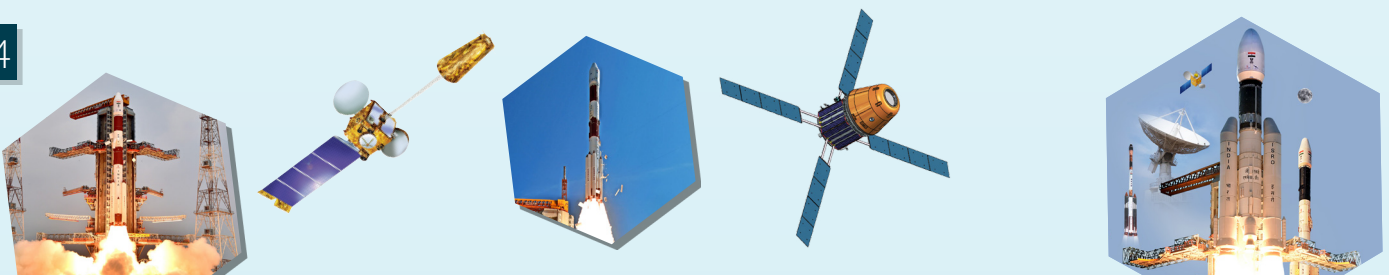

# Low Cost Multi Standard Satellite Receiver (Data Dth) Technology



*Integrated module, size:1U (can be further decreased by vertical PCBs stacking)*

Space Applications Centre (SAC) has developed a low cost satellite receiver by Interfacing a USB TV tuner and Raspberry pi supporting multiple digital TV standards such as DVB-C/T/S/S2/S2x with tuning range from 950-2150 MHz at 1-45 Msps symbol rate for DVB-S/S2 standard and is successfully tested with GSAT-19 satellite link for the reception of Audio, video and data simultaneously for different symbol rates. In-house developed Akashganga application (A data repository application for admin and client side) is successfully deployed and tested on developed low cost receiver. The developed system can serve as an improvement for existing DTH set top box with data port at low cost.

## Specifications

- A common power supply has been designed for the integrated module working at standard 230V AC for easy operation. Earlier design required separate power supplies for both Tuner and Raspberry Pi.
- Receiver supports multiple standards such as DVB-C/T/S/S2/S2x with tuning range from 950-2150 MHz at 1-45 Msps symbol rate for DVB-S/S2.
- Receiver works on Linux based Operating System (Raspbian) which offers added security aspect as compared to windows.
- Single line terminal commands to scan, tune and lock the receiver.
- Receiver is IPTV supportable.
- Wi-Fi functionality in receiver allows user to connect it via mobile/Tablet and access

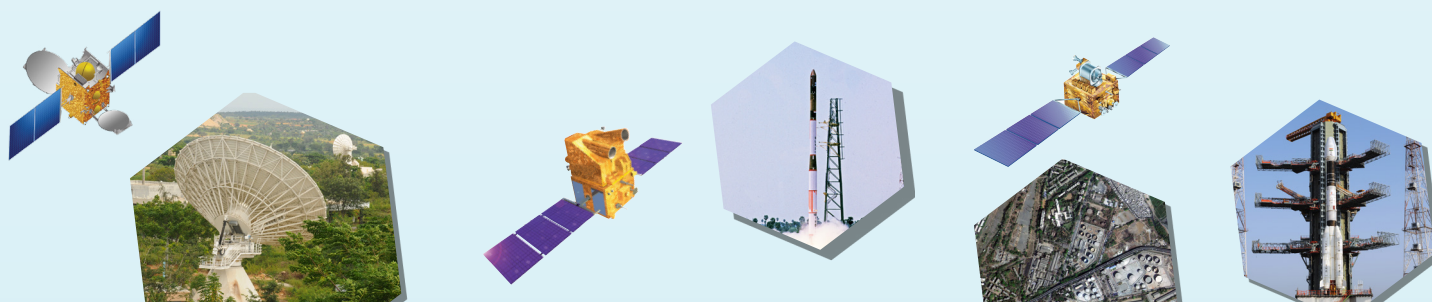

information/data remotely.

- Standard F-Type(Female) RF/LNB input connector.
- Lock state and power indicator LED is provided.
- Small size and low cost.

## Future developments

- System modification in progress to make it DVB-S2X reception compatible too which will further enhance its performance.
- To make it more compact and portable i.e. battery operated.

## Program Linkage/Application Areas

- ISRO's Tele-Education broadcasting program and Disaster Warning System.
- Can be deployed at information Kiosks at remote locations where terrestrial network is not available.

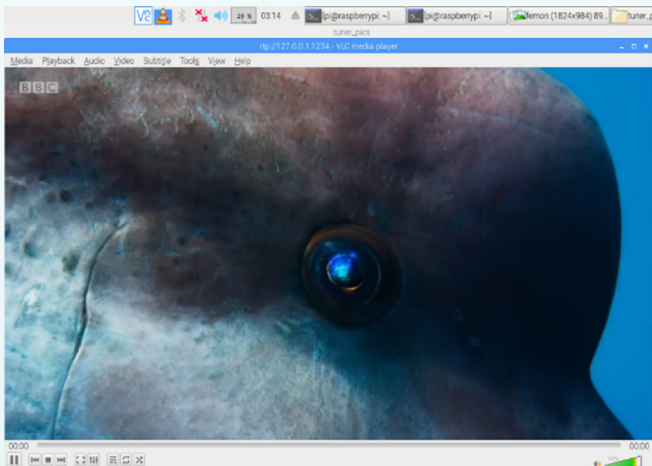

Reception of High definition Audio video and data simultaneously on the developed receiver

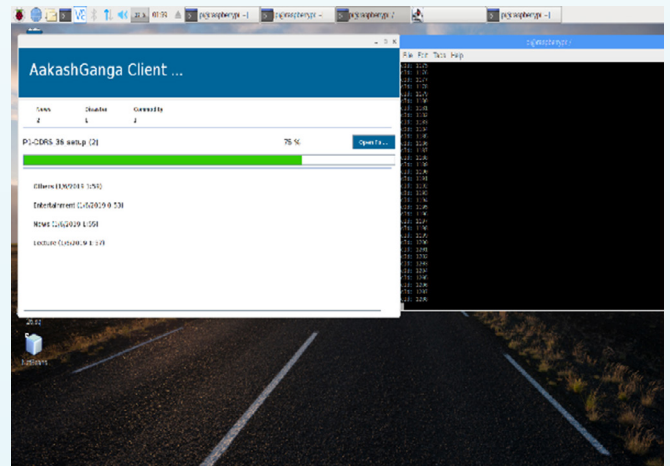

## Technology Transfer from ISRO

ISRO is willing to offer the knowhow of this technology to suitable entrepreneurs / industries in India. Capable manufacturing industries interested in acquiring this knowhow may write with details of their present activities, requirements and plans for implementation, infrastructure and technical expertise available with them, their own market assessment, if any, and plans for diversification to the address given below:

NewSpace India Limited (NSIL)

Email: [contact-nsil@isro.gov.in](mailto:contact-nsil@isro.gov.in)

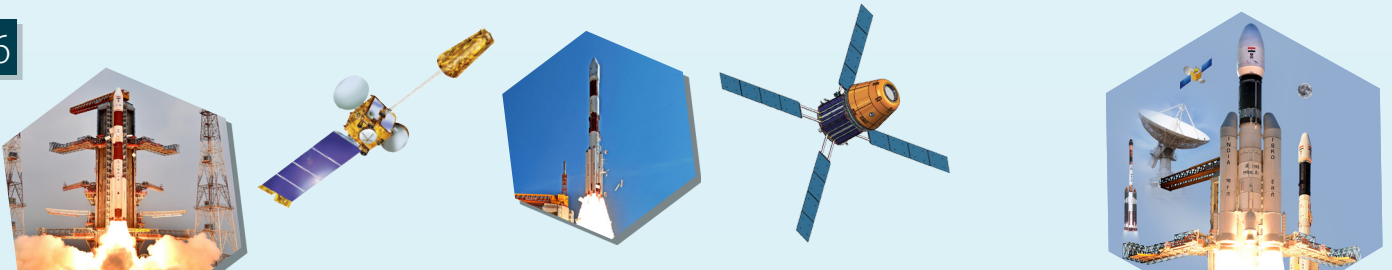



# Pseudolite Based Navigation System



*Tx Antenna for Pole*

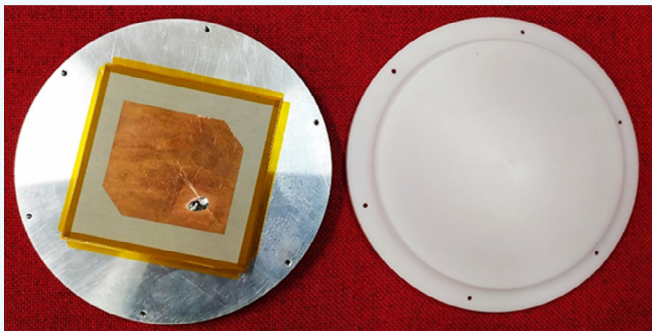

*Rx Antenna for Pole*

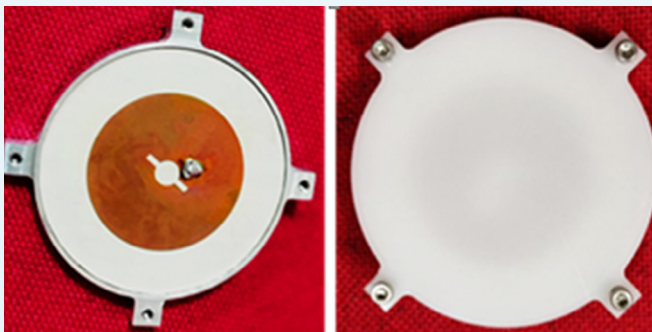

*Rx Antenna for onboard receiver*

Space Applications Centre (SAC) has developed Pseudolite based navigation system (PBNS) which is a standalone ground-based navigation system and provides an alternate means for navigation without using any Global Navigation Satellite System (GNSS). PBNS is a kind of NavIC system on ground with coverage up to 10 km range. Pseudolite Based Navigation System has two major segments which includes Ground Segment and User Segment. Ground segment consists of 10 pseudolite transceivers which generate BPSK modulated navigation signals and transmits them at S-band frequency in pulse-CDMA mode. User receiver which is on-board an aircraft receives signals from ground based transmitters and processes them to compute user position after time synchronization.

## Application Areas

The developed system will be helpful in minimizing the impact of the degradation of the GNSS services when used with in combination with GNSS as well. PBNS is also expected to support the positioning services for key operational capabilities for aircraft landing while maintaining full system capacity and also will support GAGAN for Cat III precise landing in future. PBNS will also be useful for navigation of unmanned aerial vehicles in both civil and strategic domains and interplanetary missions such as navigation on Mars as well.

Such a standalone system will also be worthy in scenarios where:

- GNSS is not available
- GNSS is compromised/denied
- GNSS is not feasible to be use

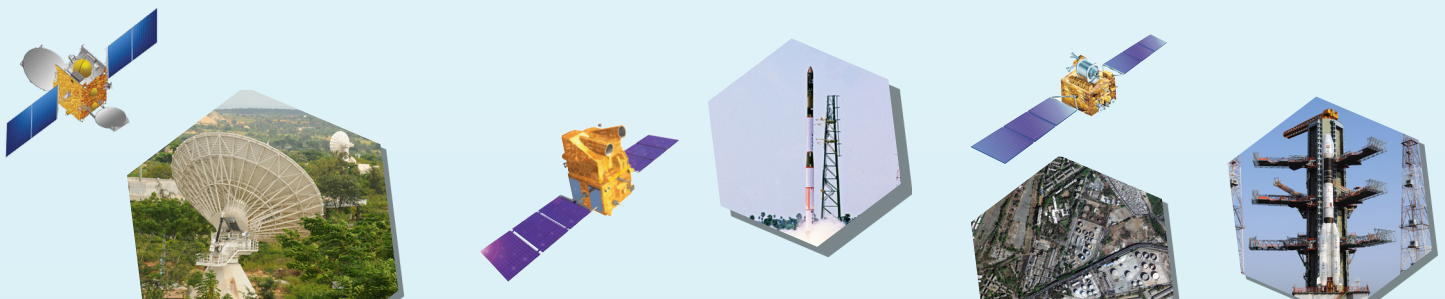

### Specifications:

- PBNS is a standalone system which works without any GNSS.
- PBNS works with low-cost pseudolite transceivers and do not use atomic clocks.
- PBNS is a passive ranging self-synchronized system.
- PBNS uses S band ISM license free spectrum.

Parameter	Unit	Value
Transmit Frequency	MHz	2414.28
EIRP	dBW	6 (maximum)
Transmit Mode	0 to 100%	Pulsed
Duty Cycle	%	10

Pseudolite System Parameters

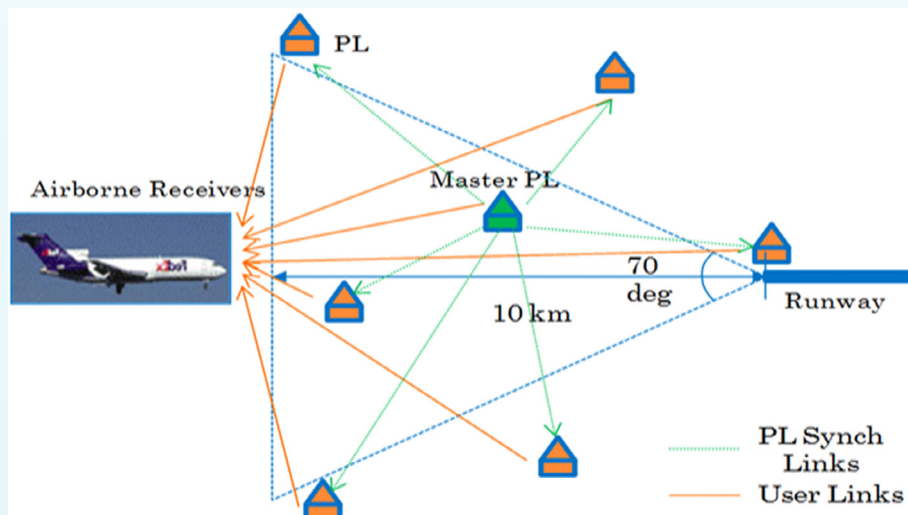

Concept of Pseudolite-Based Navigation System

### Technology Transfer from ISRO

ISRO is willing to offer the knowhow of this technology to suitable entrepreneurs / industries in India. Capable manufacturing industries interested in acquiring this knowhow may write with details of their present activities, requirements and plans for implementation, infrastructure and technical expertise available with them, their own market assessment, if any, and plans for diversification to the address given below:

NewSpace India Limited (NSIL)

Email: [contact-nsil@isro.gov.in](mailto:contact-nsil@isro.gov.in)

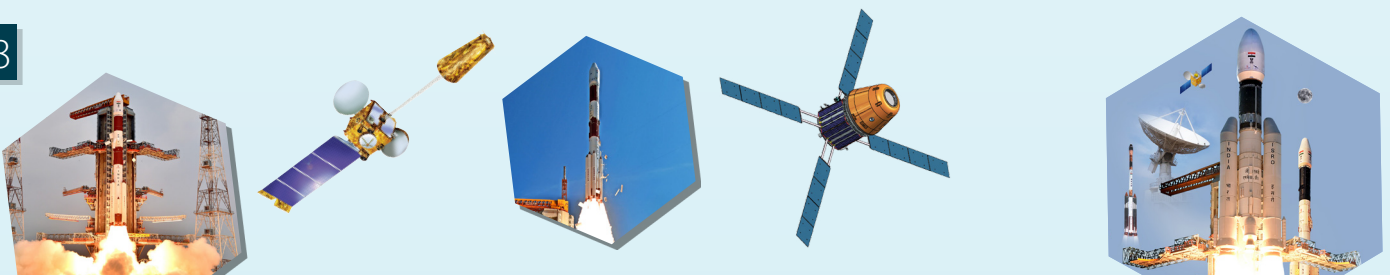

# Ferrite based Wave guide Circulators and Isolators

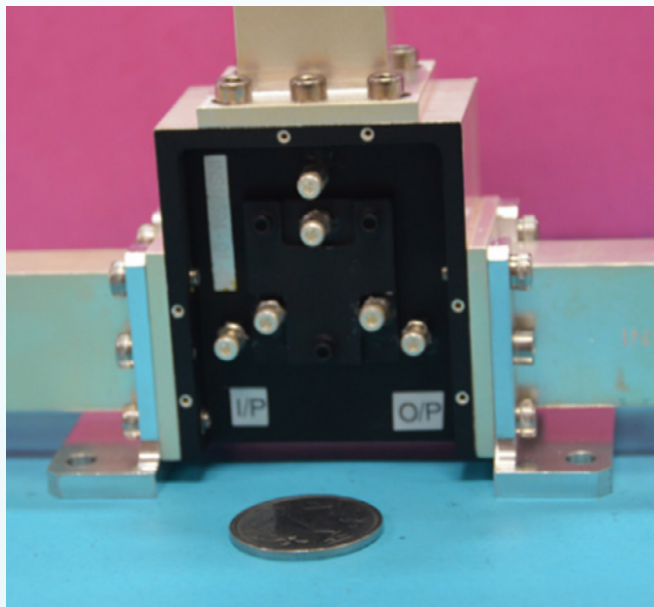

*Ku Band HP WG Circulator*

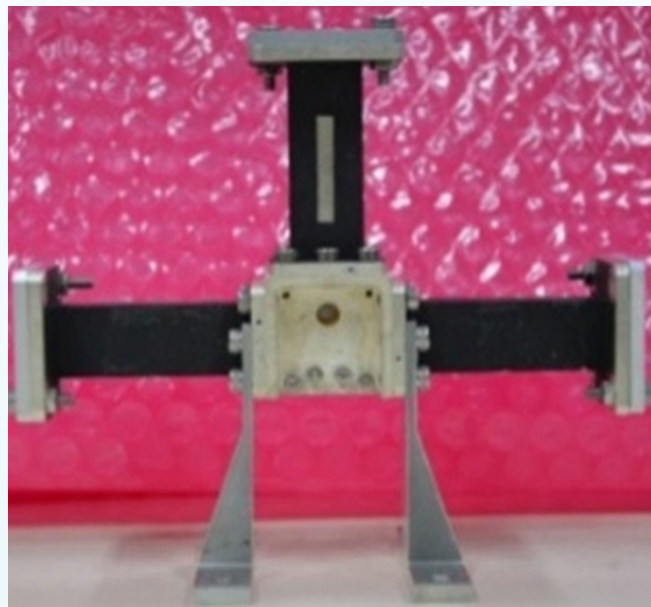

*Ka Band HP WG Circulator*

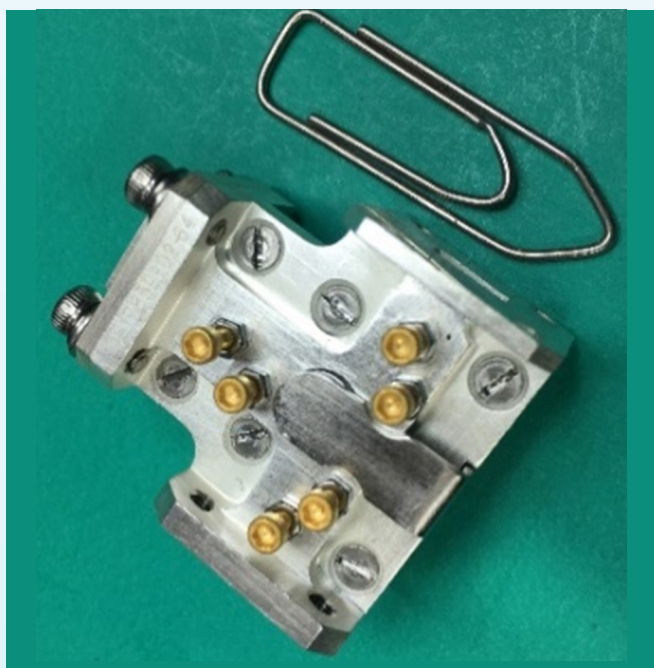

*Ka Band Low power Isolator*

Space Applications Centre (SAC) has developed Ferrite based high power waveguide circulators at Ku band and Ka band and low power isolators at Ka band and have been successfully qualified for space use.

A circulator is an important non-reciprocal device which has wide applications in conventional communication and radar systems both as a duplexer and an isolator. It is used to provide perfect match conditions to devices connected at its input and output by isolating them.

## Applications area

Industries involved in the development of high power transmitters and low power receivers for space based and terrestrial applications at these frequencies are the potential users.

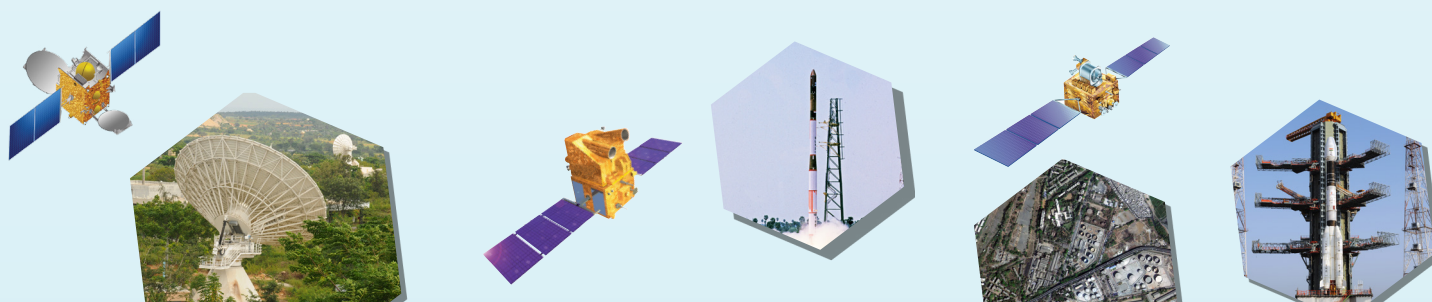

## Specifications:

- Y – junction ferrite waveguide circulator
- State of the art design with similar performance
- Thermally stable performance over -10 to 75 °C due to excellent thermal design for handling high power
- Wide band design to cover entire allocated frequency bands at Ku and Ka band

S. No.	Parameter	Specification		
		Ku Band High Power	Ka Band High Power	Ka Band Low Power
1	Frequency Range (GHz)	10.7-12.75	17.7-20.7	27.5-30.5
2	Insertion Loss (dB)	< 0.15	< 0.2	< 0.2
3	Return Loss (dB)	> 21	> 21	> 20
4	Isolation (dB)	> 21	> 21	> 20
5	Power Handling (W)			
	Average (Forward+Reverse) Peak	210 840	130 520	Low Power

## Technology Transfer from ISRO

ISRO is willing to offer the knowhow of this technology to suitable entrepreneurs / industries in India. Capable manufacturing industries interested in acquiring this knowhow may write with details of their present activities, requirements and plans for implementation, infrastructure and technical expertise available with them, their own market assessment, if any, and plans for diversification to the address given below:

NewSpace India Limited (NSIL)

Email: [contact-nsil@isro.gov.in](mailto:contact-nsil@isro.gov.in)

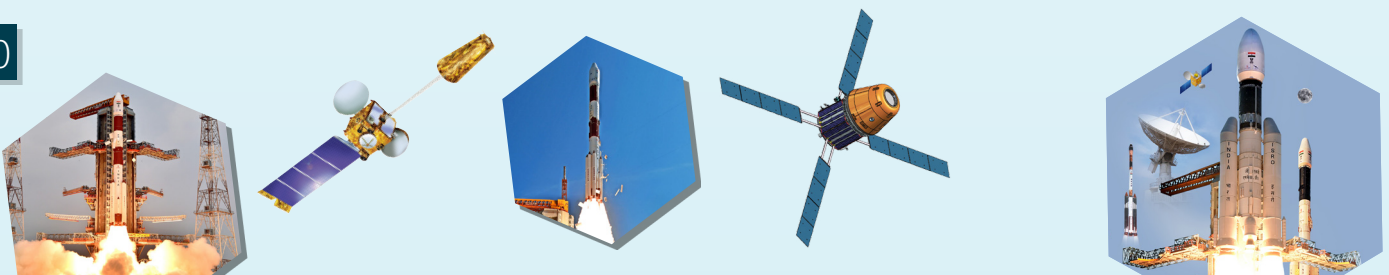

# High Power Circulator-Switch Assembly

The X-Band circulator-switch assembly is a 3 port system for signal duplexing between the payload transmitter and receiver systems in SAR payloads where a single antenna is used for both transmission and reception of signals. It protects the receiver during transmit window and isolates the transmitter during receive window. It consists of 01 ferrite circulator and 02 ferrite switches inside each unit. It has switching time of under 2.5us and is capable of handling up to 2kW peak power and 440W average power in space. The switches are commanded by a 5V TTL input from the payload controller which synchronizes the CSA with the transmit and receive timings of the payload.

## Specifications:

- Very fast switching speed of under 2.5 us
- Isolation of 60dB between transmitter and receiver during transmit window.
- Transmit loss of 0.25dB and receive loss of 0.85dB over 600 MHz at operating temperature range
- Capable of high RF power handling. Tested for power handling and multipaction up to 500W average and 6kW peak RF power at thermo-vacuum conditions.
- In-built driver for generating magnetic flux based on external TTL input.
- The unit has undergone thorough space qualification including
  - S-parameter characterization from -150C to 550C at vacuum
  - Qualification level vibration & mechanical shock.
  - Multipactor & vacuum power handling testing at 6kW peak and 440W average power respectively

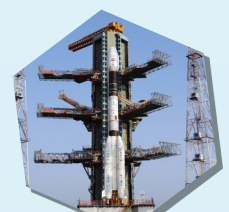
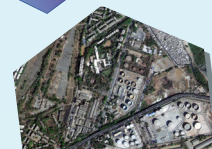
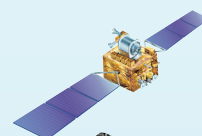
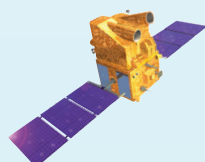
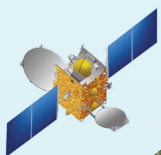
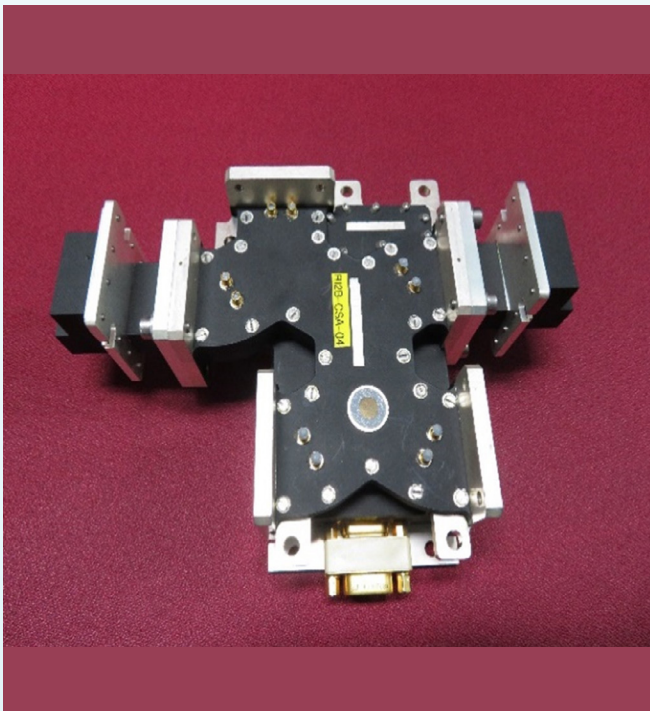

## Applications

The Circulator-Switch Assembly is the crucial front-end element of high power microwave remote sensing payloads where a common antenna is shared by the high power transmitter and the low power receiver. It protects the receiver by providing more than 60dB of isolation during the transmit window. With switching speed as low as 2.5us, it is also the duplexing mechanism between transmit and receive signals of the payload. The CSA is subject to the full payload output power and hence tested up to 6kW of peak power and 440W average power. Typical transmit loss of the unit is better than 0.25 and receive path loss better than 0.85dB over 600 MHz bandwidth at 9.6 GHz center frequency.

Specifications for 8 X 8 Butler Matrix	
Parameter	Specifications
Frequency	9.3 – 9.9 GHz
Transmit path Loss (over 600 MHz)(from -15°C to 55°C)	0.25 dB (max)
Receive path Loss (over 600 MHz) (from -15°C to 55°C)	0.85 dB (max)
Return Loss (600 MHz)	16 dB(min)
Peak Power Handling	2 KW
Average Power Handling	440W
Full power operating temperature (base-plate)	-10°C to 50°C
Switching Speed	2.5us (max)
Interface	WR90 waveguide
Mass	0.7 kg (max)

## Technology Transfer from ISRO

ISRO is willing to offer the knowhow of this technology to suitable entrepreneurs / industries in India. Capable manufacturing industries interested in acquiring this knowhow may write with details of their present activities, requirements and plans for implementation, infrastructure and technical expertise available with them, their own market assessment, if any, and plans for diversification to the address given below:

NewSpace India Limited (NSIL)

Email: [contact-nsil@isro.gov.in](mailto:contact-nsil@isro.gov.in)

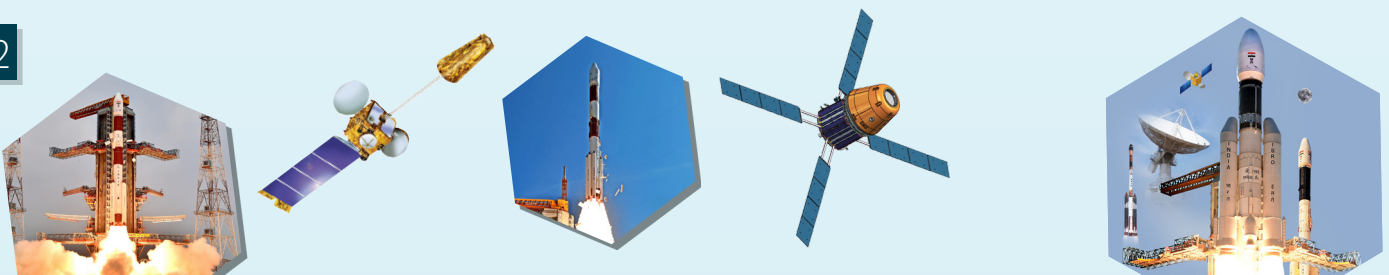

# MiniSAR: X band Airborne SAR

## Salient Features

- A miniaturized airborne synthetic aperture radar@X band.
- Spatial resolution of around one foot.
- Swath: 5 km.
- Imaging in stripmap mode.
- Single, dual or circular polarization.
- Weight: 5.5kg SAR electronics.
- SAR designed for airborne platform height of 3km to 10 km @ maximum Velocity of 120 m/s.

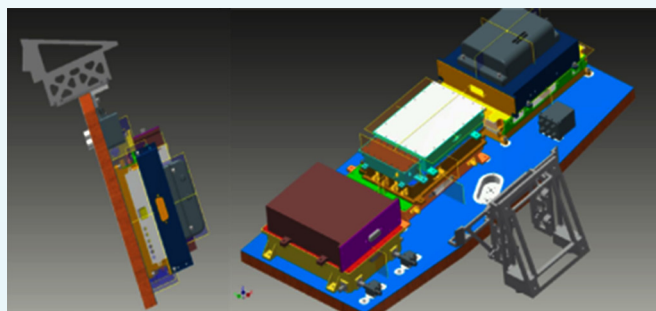

speed, wide band direct digital chirp synthesis based Chirp Generator.

- Inbuilt Payload Controller for Control, Coordination and status monitoring and timing and control signal generation for different subsystems.
- Operator Console software.
- High speed miniaturized Solid State Recorder.

## Potential Applications

- High resolution imaging
- Disaster management
- Urban planning
- 'Anytime imaging', day or night from airborne platform

## MiniSAR : Technology

- Light weight, dual polarized, broadband, X-band, planar Antenna.
- Compact GaN MMIC based dual polarized Solid state Power Amplifier with pulse modulators.
- MMIC based multi frequency and broadband X Band LFM Frequency Generator on single board.
- LTCC based dual polarized, Low noise, high gain Receiver.
- Miniaturized Pulsed/CW electronic power conditioners.
- High speed quad channel digitizer and High

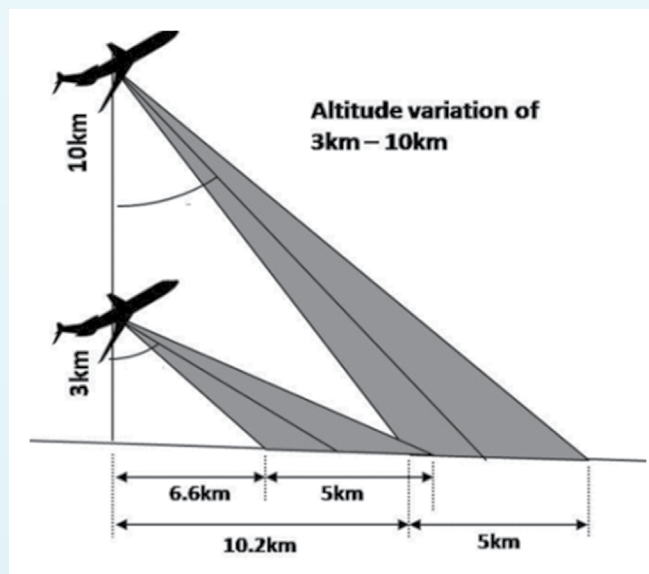

Imaging Geometry

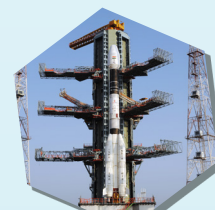
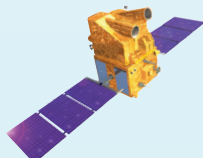
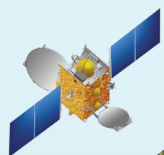

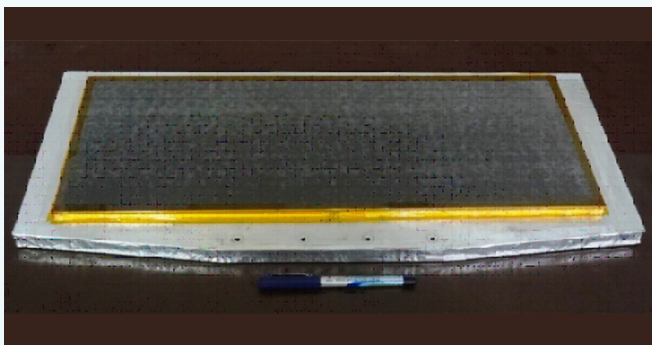
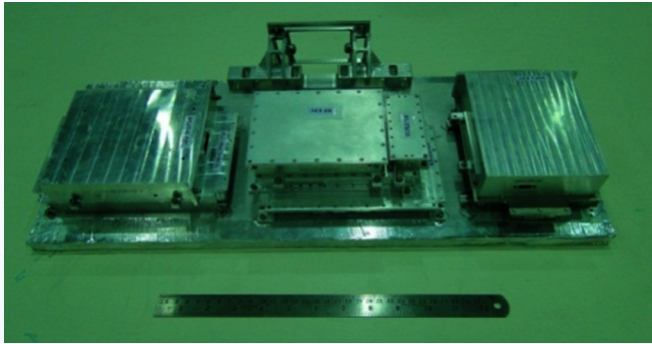

**Weight :5.5Kgs**  
**Size : 260mm X 590 mm X110mm**  
**DC Power : 130W**

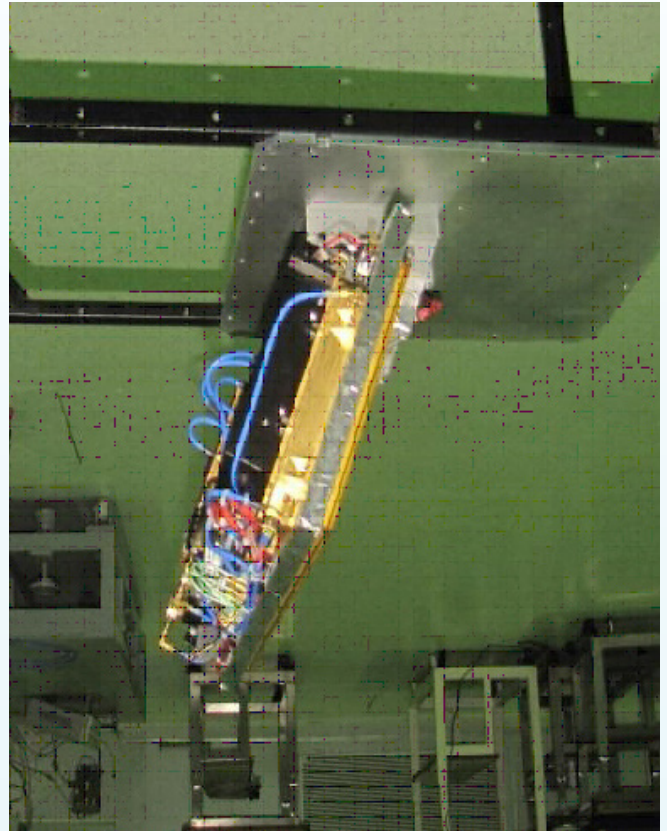

## Technology Transfer from ISRO

ISRO is willing to offer the knowhow of this technology to suitable entrepreneurs / industries in India. Capable manufacturing industries interested in acquiring this knowhow may write with details of their present activities, requirements and plans for implementation, infrastructure and technical expertise available with them, their own market assessment, if any, and plans for diversification to the address given below:

NewSpace India Limited (NSIL)  
Email: [contact-nsil@isro.gov.in](mailto:contact-nsil@isro.gov.in)

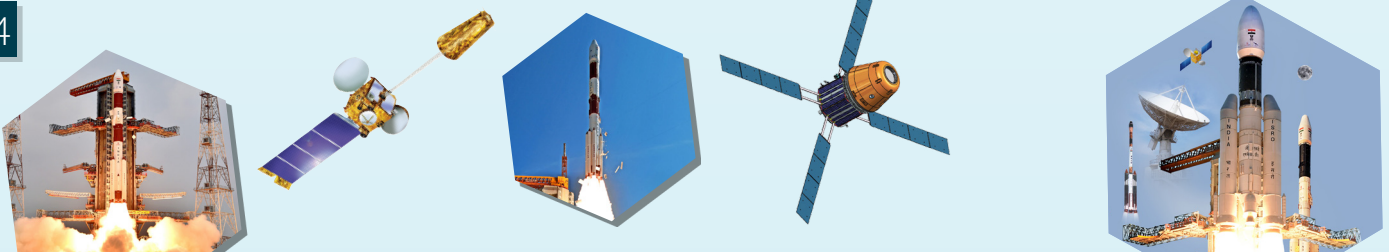



## SCPC Modem IP Core

SAC has designed and developed a SCPC modem IP core performs modulation & demodulation for enabling two communications through satellite network. Modem takes binary data from user, performs scrambling, FEC encoding & pulse shaping operations and provides modulated complex baseband samples for DAC. Similarly, it demodulates the modulated signal & performs FEC decoding & descrambling operations and provides binary data at output. SCPC modem has serial synchronous data interface with HDLC encapsulation option for packet type data.

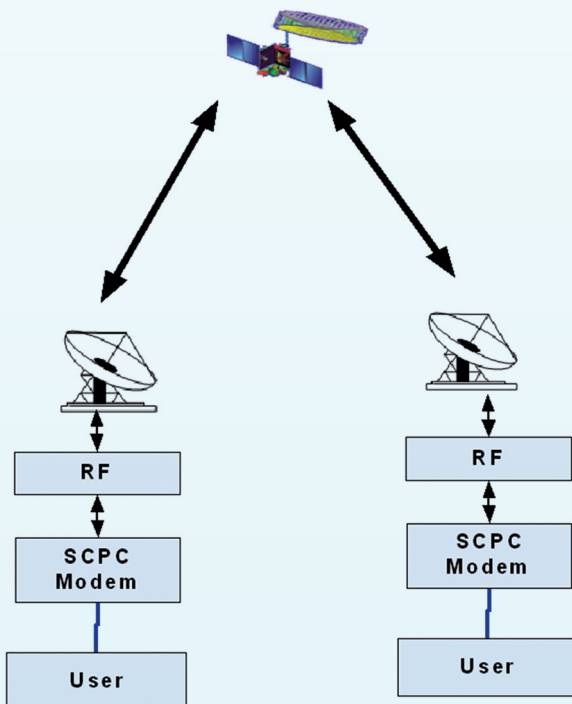

Typical Diagram of SATCOM link with SCPC Modem

### Applications

- In SATCOM Hub stations & terminals for enabling two-way point to point communication in continuous mode
- Two-way Audio/video & data communication over satellite network

### Features

Modulation	BPSK/QPSK
Data Rate	32Kbps-2Mbps
Data Interfaces	Serial Synchronous
Forward Error Correction(FEC)	Conv. (K=7, R= 1/2, 3/4) +Reed Solomon (short)-optional
Scrambler	V.35 (IESS-308)
Phase Ambiguity	Differential Encoding/Decoding
Acquisition Range	< ±Symbol Rate/8
Encapsulation	HDLC / Custom (details to be provided)
Required Eb/No for BER of 1x10 <sup>-6</sup>	6.0 dB (including implementation margin)
Dynamic Range	30 dB
ADC/DAC interface	12 bit I/Q Samples

### Deliverables

- Bit file/Encrypted Netlist of the HDL IP is provided.
- One time(limited) HDL IP porting support is provided

### Present Platform Details

FPGA	Xilinx Artix-7
RF Transceiver	AD9364/AD9361
Tx/Rx Frequency	L-Band
Data Interface	Serial/Ethernet

NewSpace India Limited (NSIL)

Email: [contact-nsil@isro.gov.in](mailto:contact-nsil@isro.gov.in)

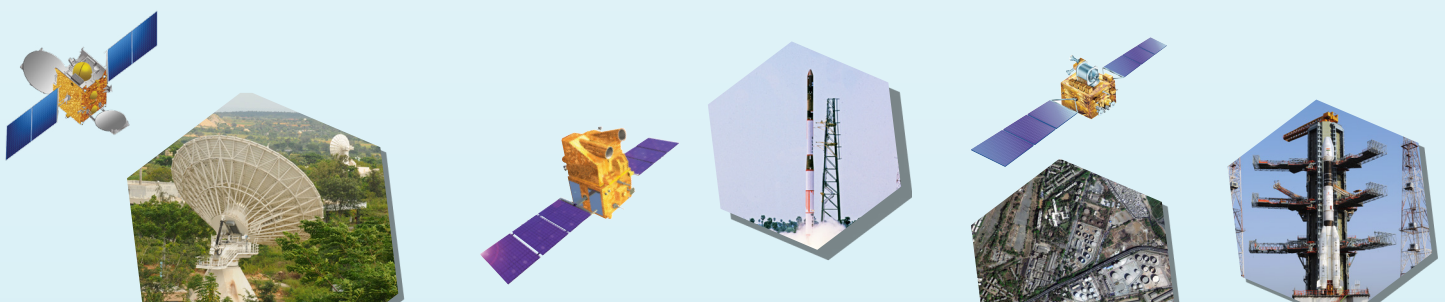

# V Band Low Noise Amplifier

Space Applications Centre of ISRO has developed a low noise amplifier designed at V band. It operates at 50 – 60GHz and gives a gain of 7-10dB. The typical noise figure is less than 5dB. It is also a medium power amplifier with 14 dB output power at 1dB gain compression. The amplifier has waveguide WR-15 interface at the input and output

## Typical Applications

- EW Receivers
- Weather & Military ultra wideband radar applications
- Ultra wideband communication networks

## Salient Features

- Frequency : 50-60GHz
- Noise Figure : 5 dB
- Gain : 8.5dB (Higher Gain option available)
- Output Power at (@P1dB) : 14dBm
- DC power consumption : 80mA , 3V
- Input / Output : Waveguide WR15

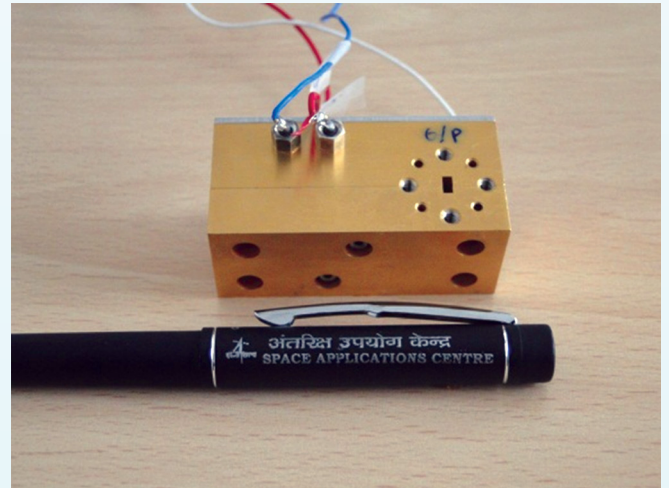

Frequency (GHz)	Gain (dB)	Noise Figure (dB)	P1dB (dBm)	DC Bias
50-60	8.5dB±1.5dB	5	14	3V,80mA

## Technology Transfer from ISRO

ISRO is willing to offer the knowhow of this technology to suitable entrepreneurs / industries in India. Capable manufacturing industries interested in acquiring this knowhow may write with details of their present activities, requirements and plans for implementation, infrastructure and technical expertise available with them, their own market assessment, if any, and plans for diversification to the address given below:

NewSpace India Limited (NSIL)  
Email: [contact-nsil@isro.gov.in](mailto:contact-nsil@isro.gov.in)

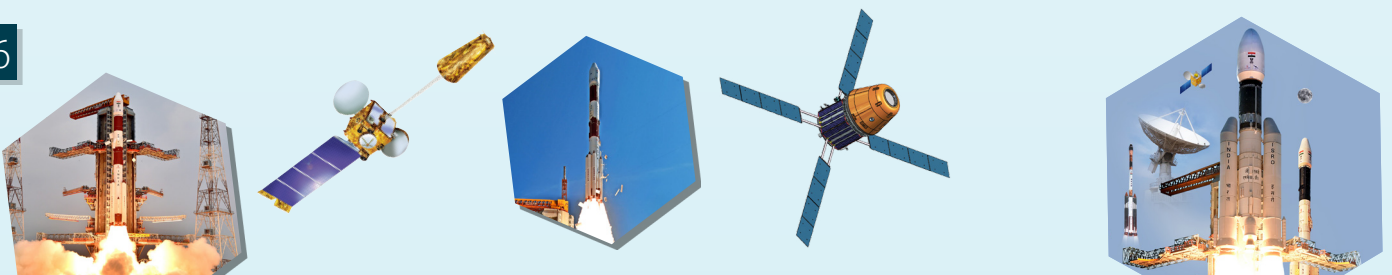

# 21 NA Pressure Transducer

Indian Space Research Organization (ISRO) at its Liquid Propulsion Systems Centre has developed a novel 21 NA Pressure Transducer, which will find wide industrial and commercial applications.

## Principle of Operation

21NA Pressure transducers which is space qualified has outstanding features such as light weight, high accuracy and ruggedness. These transducers are intended for absolute pressure sensing. The active element is a

stainless steel membrane which senses the pressure to be measured. The membrane transmits a force in proportion to the pressure, to an isostatic beam on which four active strain gauges are bonded in a wheat stone bridge circuit. These transducers are totally enclosed, adequately temperature compensated and are designed to operate even under adverse environmental conditions. They are hermetically sealed and suitable for high humidity environment as well. Any failure of the sensing element will be contained within the sensor and no catastrophic damage outside is ensured. These transducers have a heritage of long term use in satellites



as well. These sensors have 30 years heritage in ISRO launch vehicle programmes. These transducers are mainly meant for application in the areas of aerospace, process industries, air and gas compressors, oil and gas, wind tunnel studies etc.

## Advantages & Salient Features

- Compact & Light weight
- Hermetically Sealed
- Can withstand Shock 50grms
- Vibration resistance upto 30grms
- High Dynamic response
- Compatible with corrosive fluid environments.

## Application

- Aerospace
- Defense
- Process Industries
- Atomic energy
- Air and Gas Compressors
- High Dynamic response
- Compatible with corrosive fluid environments.
- Oil and gas industry.
- Automobiles Wind
- Tunnel Studies etc.
- Oceanography

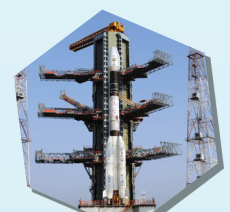
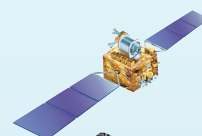
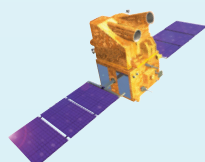
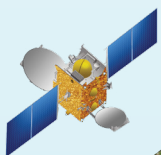

## Specifications

Measuring Ranges (Bar)	0-3, 0-5, 0-7, 0-10, 0-15, 0-20, 0-30, 0-50, 0-70, 0-100, 0-200, 0-300 and 0-330 Bar.
Nominal Excitation	10 V DC $\pm$ 5 m V
Safe over load For 0-3 to 0-20 bar For 0-30 bar For 0-50 to 0-200 bar For 0-300 to 0-330 bar	2X Nominal pressure 40 bar 2X Nominal pressure 500 bar
Full Scale Output (FSO) For 10 Volts Excitation	20 to 21 m V
Non Linearity + Hysteresis For 0-30 to 0-300 Bar For 0-330 Bar	$\leq$ 0.7% FSO $\leq$ 0.85% FSO
Hysteresis	$\leq$ 0.5% FSO
Sensitivity	$2_{-0}^{-0.1}$ mV/V
Zero & Nominal point drift in temperature	$\leq 2 \times 10^{-4}$ / FSO/ $^{\circ}$ C
Noise Due to Vibration	$\leq$ 1% FSO
Mass	$\leq$ 100 grams
Electrical interface	Multi-pin hermetically sealed connector

## Technology Transfer from ISRO

ISRO is willing to offer the knowhow of this technology to suitable entrepreneurs / industries in India. Capable manufacturing industries interested in acquiring this knowhow may write with details of their present activities, requirements and plans for implementation, infrastructure and technical expertise available with them, their own market assessment, if any, and plans for diversification to the address given below:

NewSpace India Limited (NSIL)

Email: [contact-nsil@isro.gov.in](mailto:contact-nsil@isro.gov.in)

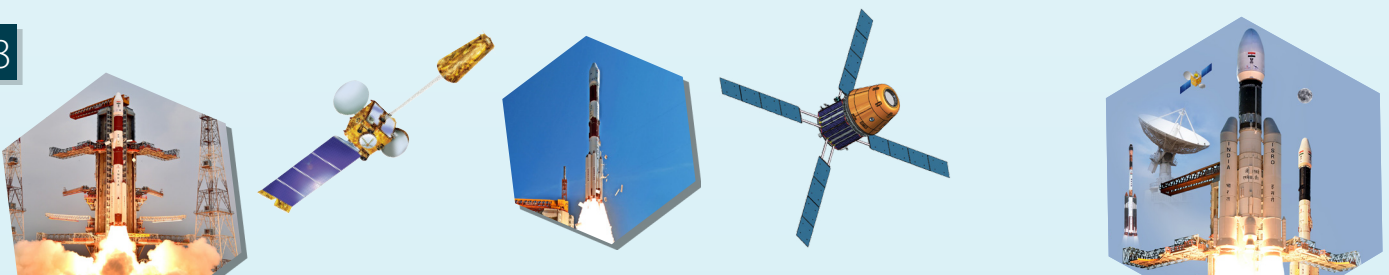

# Differential Pressure Transducer (DPT)

Indian Space Research Organization (ISRO) at its Liquid Propulsion Systems Centre has developed a novel Differential Pressure Transducer (DPT), which will find wide industrial and commercial applications.

## Principle of Operation

A DPT is used where the difference in pressures at two points are to be measured. The forces developed due to these pressures (say P1 and P2) act on a balanced beam called sensing element. Four resistance foil strain gauges are bonded on this sensing element beam which deforms proportionately to the difference between P1 and P2. The electrical output signal is positive when P1 is greater than P2 and vice versa. A mechanical stopper limits the deflection of sensing beam within the specified limits.

The DPT can be used for liquid medium or gaseous medium or even a combination of both. They are

hermetically sealed and suitable for high humidity environment as well. Any failure of the sensing element will be contained within the sensor and no catastrophic damage is caused to the system.

## Advantages & Salient Features

- Rugged
- Hermetically Sealed
- Vibration resistance
- Compatible with corrosive fluid environments.

## Application

- Aerospace
- Atomic energy
- Process Industries
- Air and Gas Compressors
- Oil and gas industry's

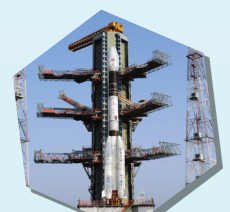
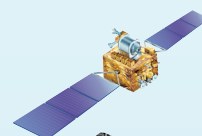
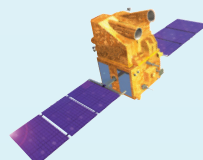
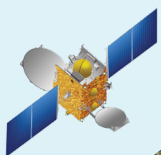

## Specifications

Differential pressure range	$\pm 3, \pm 5, \pm 7, \pm 10, \pm 20$
Line pressure	65 bar Safe
overload	75 bar
Excitation	$10V \pm 5 mV$
Output	$10mV \pm 5 mV$
Non Linearity + Hysteresis	$\leq 0.5\% \text{ F.S.O}$
Hysteresis	$\leq 0.3\% \text{ F.S.O}$
Sensitivity	$\pm 1mV/V \pm 0.1$
Zero & F.S.O drift in temperature	$\pm 3 \times 10^{-4} / \text{F.S.O} / ^\circ \text{C}$
Noise due to vibration	$\leq 1\% \text{ F.S.O Mass}$ $\leq 950 \text{ gms}$
Maximum current	28 mA @ 10 V.D.C
Wetted parts	Stainless steel, 316L/304L
Electrical interface	Multi-pin hermetically sealed electrical connector

## Technology Transfer from ISRO

ISRO is willing to offer the knowhow of this technology to suitable entrepreneurs / industries in India. Capable manufacturing industries interested in acquiring this knowhow may write with details of their present activities, requirements and plans for implementation, infrastructure and technical expertise available with them, their own market assessment, if any, and plans for diversification to the address given below:

NewSpace India Limited (NSIL)

Email: [contact-nsil@isro.gov.in](mailto:contact-nsil@isro.gov.in)

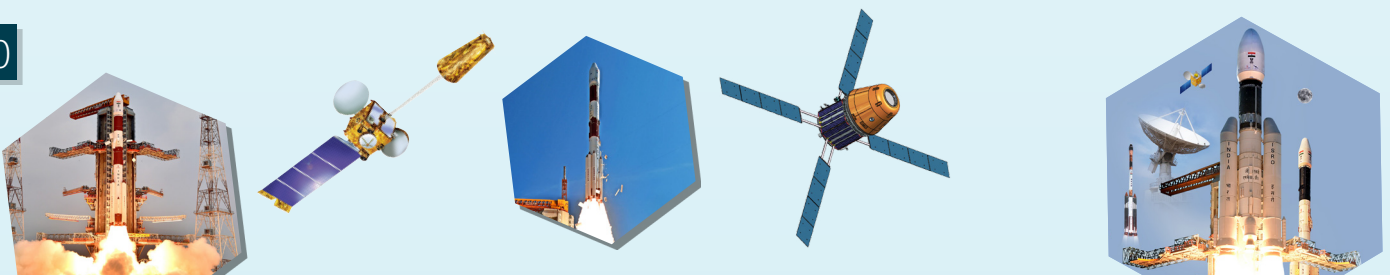

# HLP-85 Temperature Sensor

Indian Space Research Organisation (ISRO) at its Liquid Propulsion Systems Centre has developed a novel HLP-85 Temperature sensor, which will find wide industrial and commercial applications.

## Principle of Operation

Accurate and reliable measurement of temperatures in high pressure gaseous and liquid media requires dedicated and specialized thermocouple probes. The Thermocouple probe HLP-85, developed at ISRO, is qualified for measuring temperature under severe environmental conditions posed by the propellants high pressure and corrosive nature. The sensor has a heritage of 25 years in ISRO launch vehicle programmes.

The sensor uses basic elements like Chromel / Alumel with sheath and thermo well materials like 5.5 AISI 304/316/Inconel. The sensor uses unique construction techniques to obtain noise immunity and high response.

## Advantages & Salient Features

- Fast response
- Wide Temperature ranges
- Less Weight
- Shock & Vibration resistance
- Highly linear

## Application

- Space application
- Process Industries
- R&D Laboratories
- Defence Application
- Atomic
- Commercial Application
- Oil & Gas Industries

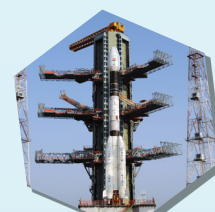
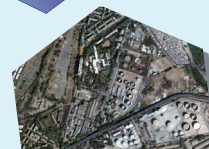
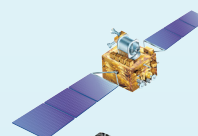
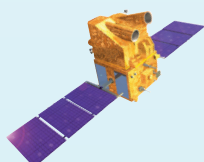
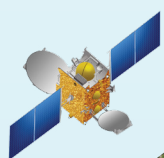

## Specifications

Temperature Range	-196 °C To +250 °C
Thermo Couple	K Type (0.5 Φ) Chromel-Alumel
Junction	Ungrounded
Pressure (Max)	350 Bar
Time Constant	≤ 0.3 s
Material Of Sheath	AISI 304 L/Z2 CN 18-10 (SS)
Insulating Material	MgO
Sensitivity	41μV/ °C
Accuracy	0 to 100 °C ±3 °C; 0 to -196 °C ±7 °C
Mass	
Electrical interface	Multi pin hermetically sealed connector.

## Technology Transfer from ISRO

ISRO is willing to offer the knowhow of this technology to suitable entrepreneurs / industries in India. Capable manufacturing industries interested in acquiring this knowhow may write with details of their present activities, requirements and plans for implementation, infrastructure and technical expertise available with them, their own market assessment, if any, and plans for diversification to the address given below:

NewSpace India Limited (NSIL)

Email: [contact-nsil@isro.gov.in](mailto:contact-nsil@isro.gov.in)

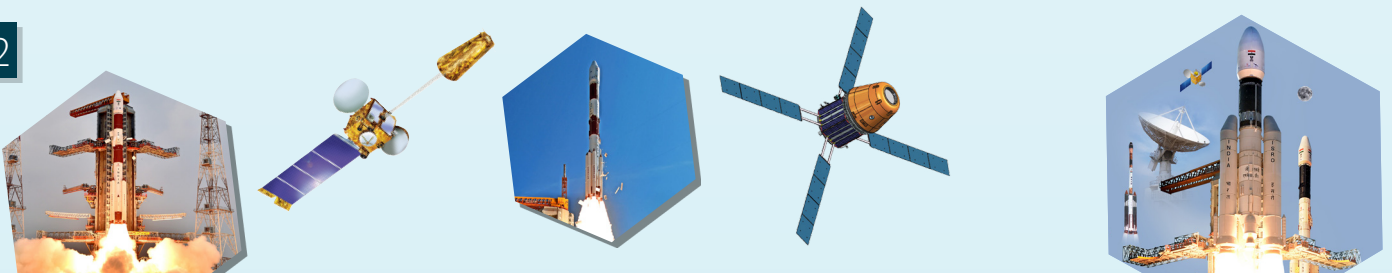



# IDLV Pressure Transducer

Indian Space Research Organisation (ISRO) at its Liquid Propulsion Systems Centre has developed a novel IDLV Pressure Transducer, which will find wide industrial and commercial applications.

## Principle of Operation

The IDLV stands for Integral diaphragm type pressure transducer, which is an absolute pressure sensor that is space qualified. The transducer has the unique characteristic like high accuracy output, rugged construction and hermetic sealing.

It has 5 fabricated parts and is especially suited for high volume production due to ease of fabrication and assembly. It has a machined diaphragm made of stainless steel for 0-30 bar to 0-500 bar pressure ranges. Four foil strain gauges are bonded on the diaphragm to measure the strain developed in it. The diaphragm is specially cryo treated to ensure high long term stability. In order to reduce power consumption 1000Ω strain gauges are selected.

Another advantage of this transducer is that it can be customized to operate in any range from 30 bar to 500 bar. Additionally, any damage to the sensing element will be contained within the sensor thus avoiding any sort of catastrophic damage in the system.

## Advantages & Salient Features

- Any range from 30 to 500 bar can be custom designed and manufactured.
- Compatible with corrosive & Harsh fluid environments

- Fully Stainless Steel Constructed
- E.B Welded and hermetically sealed
- Low Cost
- High Accuracy
- Rugged
- Shock 50grms
- Vibration resistance upto 30grms
- High Dynamic response

## Application

- Space
- Defense
- Oceanography
- Atomic energy
- Oil and gas industry
- Automobilen
- R & D laboratories
- Biomedical engineering
- Mining safety etc.,
- Process industries

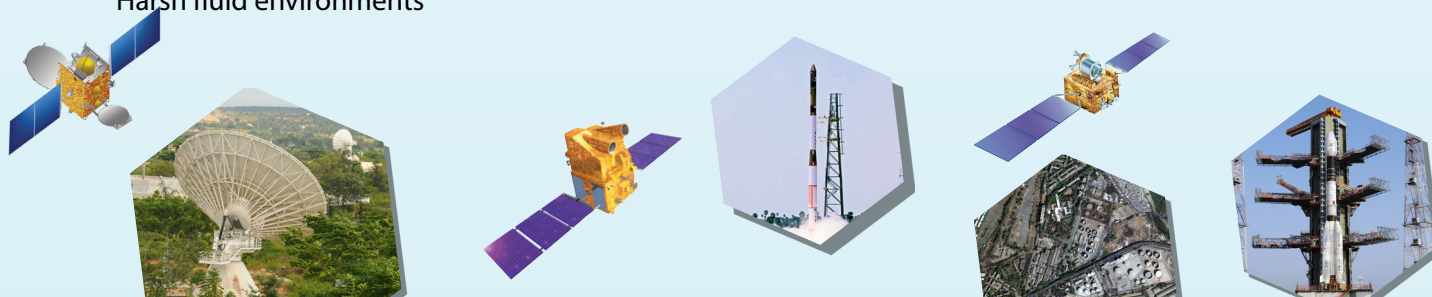

## Specifications

Range in bar	30, 50, 70, 100, 200, 300, 330 & 500 Bar (currently manufactured ranges).
Safe overload (Proof Pressure)	2 times operating pressure for all ranges
Secondary Containment Pressure	Upto 800 Bar
Nominal Excitation	10 V DC nominal
FSO for 10 V Excitation	20 mV + mV
Temperature drift of zero and FSO	$< \pm 2.0 \times 10^{-4} / \text{FSO} / ^\circ\text{C}$
Non linearity + Hysterisis	$< \pm 0.5 \% \text{ FSO}$
Sensitivity	$2 \pm 0.1 \text{ m V/V}$
Dimension / Mass	$\Phi 25 \times 72 \text{ mm} / 105 \text{ gms.}$
Electrical interface	Multi-pin hermetically sealed connector

## Technology Transfer from ISRO

ISRO is willing to offer the knowhow of this technology to suitable entrepreneurs / industries in India. Capable manufacturing industries interested in acquiring this knowhow may write with details of their present activities, requirements and plans for implementation, infrastructure and technical expertise available with them, their own market assessment, if any, and plans for diversification to the address given below:

NewSpace India Limited (NSIL)

Email: [contact-nsil@isro.gov.in](mailto:contact-nsil@isro.gov.in)

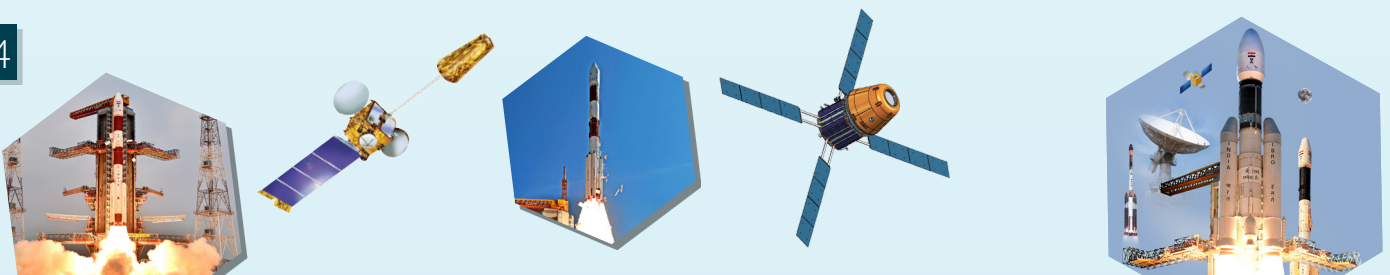

# MEMS based Pressure Transducer

Indian Space Research Organisation (ISRO) at its Liquid Propulsion Systems Centre has developed a novel MEMS Pressure Transducer, which will find wide industrial and commercial applications.

## Principle of Operation

MEMS Stands for Micro Electro Mechanical System. In the MEMS pressure transducer the Silicon technology integrates the mechanical sensing with the signal conditioning electronics making the sensor highly compact and equally accurate. In addition to its reduced weight the sensor requires only lesser power and offers high system reliability. These sensors are fabricated fully with stainless steel material and are hermetically sealed using EB welding process.

## Advantages & Salient Features

- Low power
- High accuracy
- Miniature / Low cost

- Less Weight
- High output
- Extremely low hysteresis
- Shock and vibration resistant
- High dynamic response
- High long term stability
- Suitable for low pressure measurement with high accuracy

## Application

- Suitable for control systems in all industries
- Automotive
- Defence
- Oceanography
- Atomic
- Vacuum pressure measurement
- Process and chemical Industries
- Automatic weather stations
- Space applications

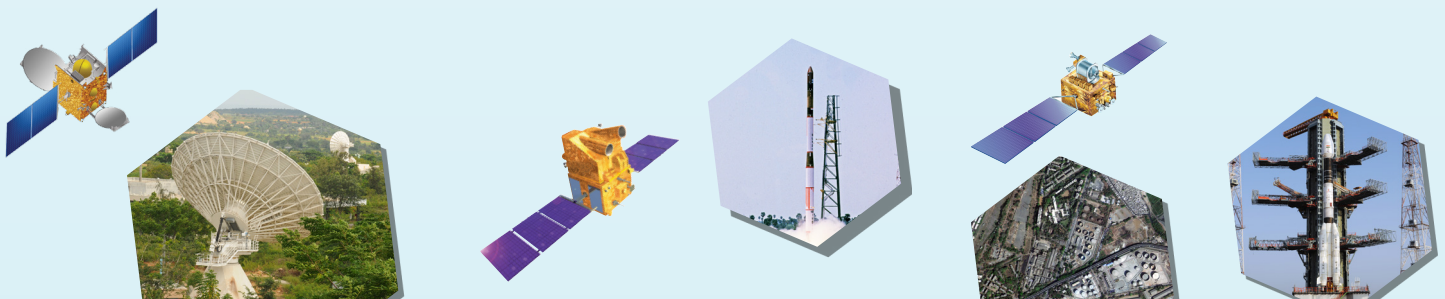

## Specifications

Pressure Range	1 bar to 250 bar (Absolute)
Excitation	5 <sup>+0.1</sup> V DC -0.0
Output Span	4 <sup>+0.1</sup> V DC (Optional) -0.0
Sensitivity	3.9 to 4.1 V/bar (Optional)
Accuracy	
Non Linearity + Hysteresis	< 0.3% FSO
Mass	75 gms
Dimensions	Ø25 x 55 mm length max
Electrical interface	Multipin hermetically sealed connector.

## Technology Transfer from ISRO

ISRO is willing to offer the knowhow of this technology to suitable entrepreneurs / industries in India. Capable manufacturing industries interested in acquiring this knowhow may write with details of their present activities, requirements and plans for implementation, infrastructure and technical expertise available with them, their own market assessment, if any, and plans for diversification to the address given below:

NewSpace India Limited (NSIL)

Email: [contact-nsil@isro.gov.in](mailto:contact-nsil@isro.gov.in)

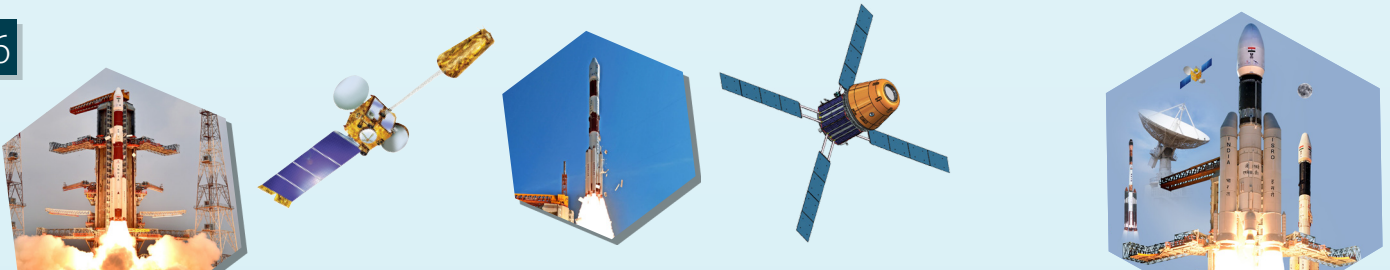

# PTS-84 Temperature Sensor

Indian Space Research Organisation (ISRO) at its Liquid Propulsion Systems Centre has developed a novel Temperature sensor, which will find wide industrial and commercial applications.

## Principle of Operation

Accurate and reliable measurement of temperatures in high pressure gaseous and liquid media requires dedicated and specialized thermocouple probes. The PTS-84 an RTD type temperature sensor, developed at ISRO, is qualified for measuring temperature under severe environmental conditions posed by the propellants high pressure and corrosive nature.

The basic element used here is a wire wound platinum sensor which has  $100\Omega$  at  $0^\circ\text{C}$  and encapsulated with S.S AISI 304/316/Inconel material. The sensor uses unique construction techniques to achieve noise immunity and high response.

## Advantages & Salient Features

- Accurate
- Reliable Measurement
- Linear
- Rugged
- Less weight
- Can withstand high flow rate
- Stable

## Application

- Space application
- Process Industries
- Atomic Purposes
- R&D Laboratories
- Defense Application
- Commercial Application
- Oil & Gas Industries

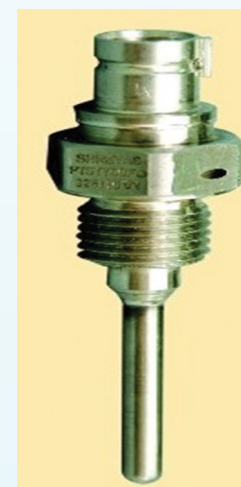

## Specifications

Temperature Range	-196°C To 250 °C
Time Constant	$\leq 3.0$ s
Material of Sheath	AISI 304L/Z2 CN 18-10 (S.S.)
Sensitivity	$0.39 \mu\text{V} / ^\circ\text{C}$
Accuracy	
Resistance at $0^\circ\text{C}$	$100.0 \pm 0.25$ ohms
Mass	$\leq 100$ g
Max. Pressure	300 Bar.
Electrical interface	Multi-pin hermetically sealed connector.

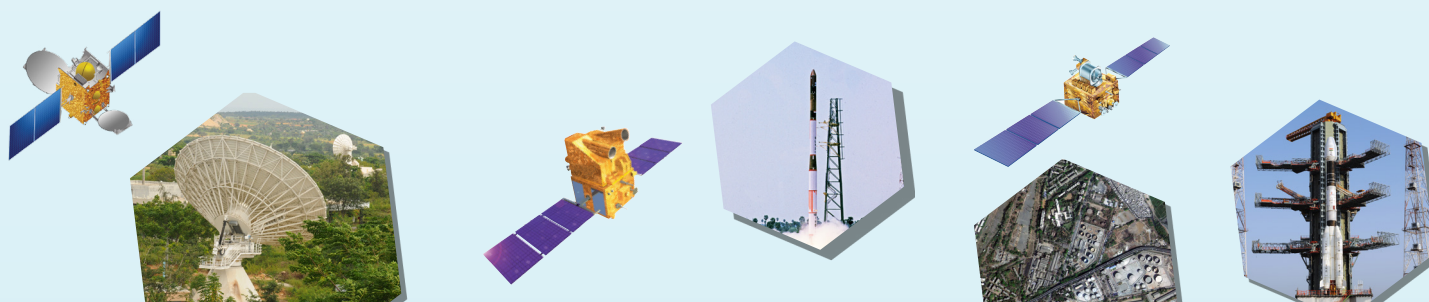

# TCP-84 Temperature Sensor

Indian Space Research Organisation (ISRO) at its Liquid Propulsion Systems Centre has developed a novel TCP-84 Temperature sensor, which will find wide industrial and commercial applications.

## Principle of Operation

Accurate and reliable measurement of temperatures in high pressure gaseous and liquid media requires dedicated and specialized thermocouple probes. The Thermocouple probe TCP-84, developed at ISRO, is qualified for measuring temperature under severe environmental conditions posed by the propellants high pressure and corrosive nature. The sensors have been tested for the temperature range of 0°C to 1100°C. The sensors have a heritage of 25 years in ISRO launch vehicle programmes.

The sensor uses basic elements like Chromel / Alumel with sheath and thermo well materials like S.S

## Specifications

Temperature Range	0 To 800°C
Thermo Couple	K Type (Chromel-Alumel)
Junction	Ungrounded (Φ 1.0)
Pressure (Max)	350 Bar
Time Constant	≤ 0.3 s
Material Of Sheath	AISI 304 L or Equivalent
Insulating Material	MgO
Sensitivity	41µV/ °C
Accuracy	0 to 400 °C ± 3 °C > 400 °C ± 0.75% of Reading
Mass	
Electrical interface	Multi-pin hermetically sealed connector.

AISI 304/316/Inconel. The sensor uses unique construction techniques to obtain noise immunity and high response.

## Advantages & Salient Features

- Fast response
- Wide Temperature ranges
- Less Weight
- Shock & Vibration resistant

## Application

- Space application
- Process Industries
- R&D Laboratories
- Defense Application
- Commercial Application
- Oil & Gas Industries

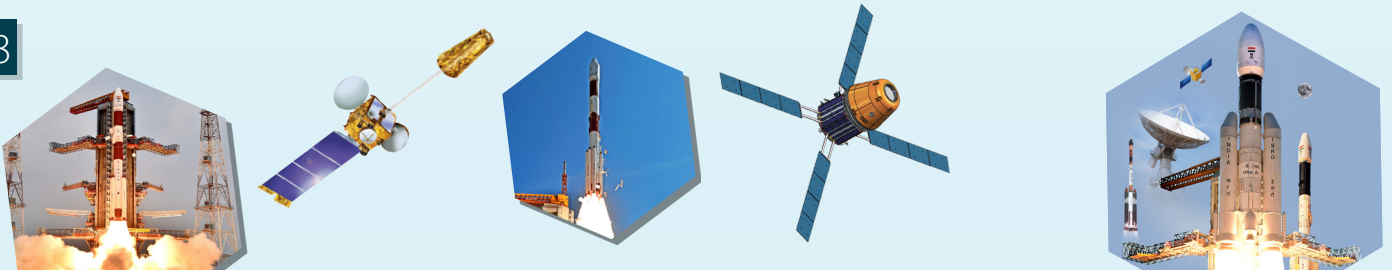

# Ultrasonic Liquid Level Sensor (USLS)

Indian Space Research Organisation (ISRO) at its Liquid Propulsion Systems Centre has developed a novel level sensor, which will find wide industrial and commercial applications.

## Principle of Operation

USLS does the function of sensing the presence of liquid medium between its sensing gap. The Standard sensor is typically integrated with the sensing element called the "SENSOR HEAD" and electrically connected to a 5 pin Lemo electrical connector. The sensor is constructed using AISI 304L stainless steel.

One Ceramic disc the "TRANSMIT TRANSDUCER" is used to convert electrical signal to an ultrasonic signal which is then transmitted across the sensing gap. The other Disk "RECEIVE TRANSDUCER" receives the ultrasonic signal and converts it into an electrical signal. The attenuation of ultrasound signals between the transmitter and receiver varies with the medium.

## Specifications

Immersion Length	125mm (Approx)
Level detection	75 mm below mounting flange
Working liquids	N <sub>2</sub> O <sub>4</sub> , UDMH & water
Fluids pressure	10 bar (Abs)
Test pressure	15 bar (Abs)
Operating Temperature	0 to 70°C
Material	SS 304 L
Vibration Resistant	13.5g, 20-2000 Hz Random
Electrical interface	Multipin electrical connector

The attenuation is high for air and low for liquids. This change in signal level enables the electric control unit (separate unit) to sense the presence or absence of liquid.

## Advantages & Salient Features

- Miniature/low cost
- Less Weight
- High output
- Low hysteresis
- Shock and vibration resistant
- High dynamic response

## Application

- Automotive
- Defense
- Oceanography
- Vacuum pressure measurement
- Process and chemical Industries
- Automatic weather stations
- Space applications

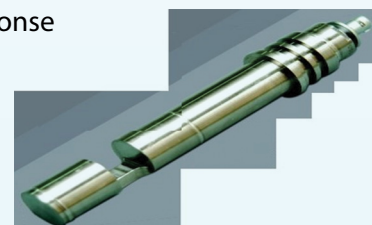

## Technology Transfer from ISRO

ISRO is willing to offer the knowhow of this technology to suitable entrepreneurs / industries in India. Capable manufacturing industries interested in acquiring this knowhow may write with details of their present activities, requirements and plans for implementation, infrastructure and technical expertise available with them, their own market assessment, if any, and plans for diversification to the address given below:

NewSpace India Limited (NSIL)

Email: [contact-nsil@isro.gov.in](mailto:contact-nsil@isro.gov.in)

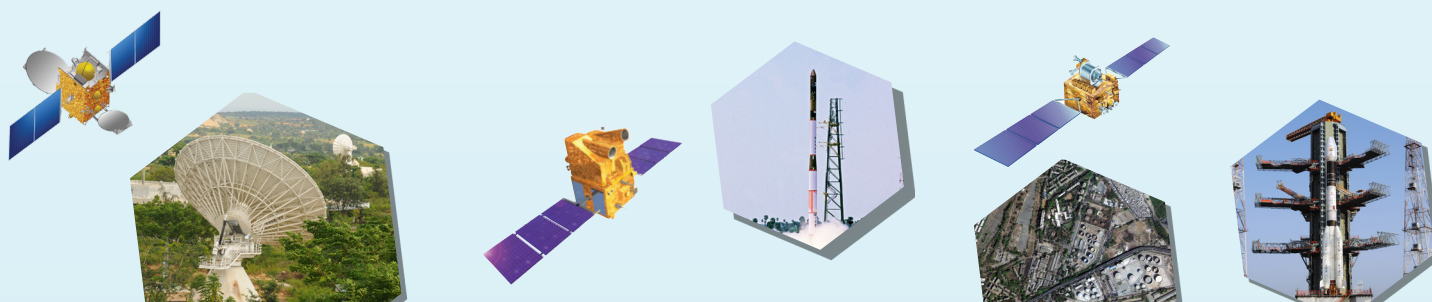

# Burst Demodulator IP Core

Space Applications Centre (ISRO) has developed a burst demodulator which performs the demodulation of PSK modulated signal being transmitted in burst mode. The demodulator expects the quantized, complex baseband samples from analog to digital convertor and recovers timing, frequency and phase of the complex baseband symbols. In addition, core handles the Viterbi decoding, Data De-scrambling & HDLC decoding for data. The core can forward the data on UART/Ethernet interface.

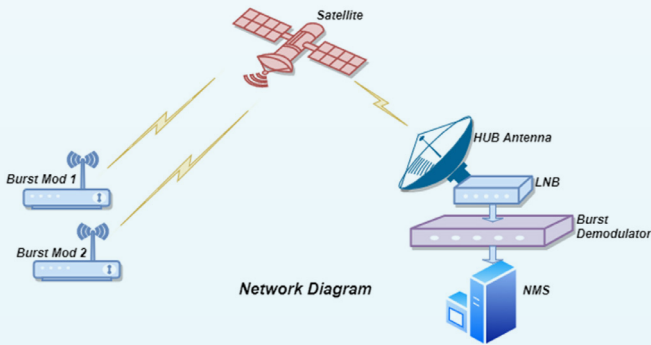

Typical Diagram of SATCOM link with Burst Demodulator

## Applications

- As Signalling demodulator in SATCOM Network at HUB station.
- In receive station enabling burst mode of communication for services like Position reporting, Asset tracking etc.

## Features

Modulation	BPSK/QPSK
Data Rate	1.2 Kbps/2.4 Kbps
Payload Length	Configurable (10-100 bytes)
Forward Error Correction (FEC)	Convolutional Rate Half 1/2, K=7
Scrambler	$1+x+x^{15}$
Data Integrity Check	HDLC (CRC-16)
Acquisition Range	Less than $\pm 4 \times$ Symbol Rate
Eb/N0	7 dB & above
Packet Error Rate(PER)	1% or less at 7 dB
Dynamic Range	10 dB
Input Format	12 bit I/Q Samples
Data Output	UART / Ethernet

## Deliverables

- Bit file/Encrypted Netlist of the HDL IP is provided.
- One time(limited) HDL IP porting support is provided

## Present Platform Details

FPGA	Zynq7035(SDR)
RF Transceiver	AD9364/AD9361
Receive Frequency	L-Band
Output Interface	UART/Ethernet

Interested vendors in India with adequate experience and manufacturing facilities can contact us on:

NewSpace India Limited (NSIL)  
Email: [contact-nsil@isro.gov.in](mailto:contact-nsil@isro.gov.in)

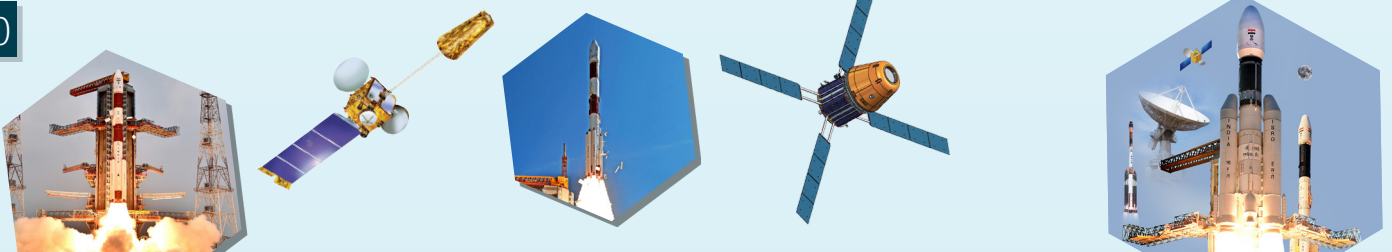



# Solid State Recorder (SSR)

SAC has designed and developed a Solid State Recorder (SSR) based on non-volatile flash memory for applications requiring high speed large volume data recording. Industry standard NAND Flash has been used to take advantage of their ever increasing density and cost reduction as technology advances. These SSRs make ideal data capture media for airborne imaging sensors as well as other applications requiring high data ingest rate real-time capacity including ground testing and archival of data. The architecture has been specially optimized for imaging sensor applications and mass, volume and power parameters. Various input connectivity options allow these recorders to be readily applied with most data heavy sources.

## Features

- Real-time recording
- ONFI Flash device based storage
- Scalable and Flexible Design
- Optimized for mass and power
- Host-based file management



## Technical Specifications

Parameter	Specifications
Sustained Input Data Rate	1.0 Giga Baud
Storage Capacity	4 Tb
Temperature Range	-20°C to +75°C
Storage Medium	NAND Flash
Mass	< 0.75 Kg
Power	< 8 Watts
Data Retrieval	USB 2.0
Input Interface	SERDES / LVDS Serial / LVDS Parallel / RS422 serial and RS232 serial
Operational Voltage	5-12 Volts (non-isolated) 9-36/18-72 Volts (Isolated)
Package Size	220 mm x 50 mm x 25 mm
Operator Interface	Custom Utility (Windows)

## Applications

- Imaging Data Recording
- High Speed Sensor Data Acquisition
- Airborne Applications
- Ground Testing and Data Archival

NewSpace India Limited (NSIL)  
Email: [contact-nsil@isro.gov.in](mailto:contact-nsil@isro.gov.in)

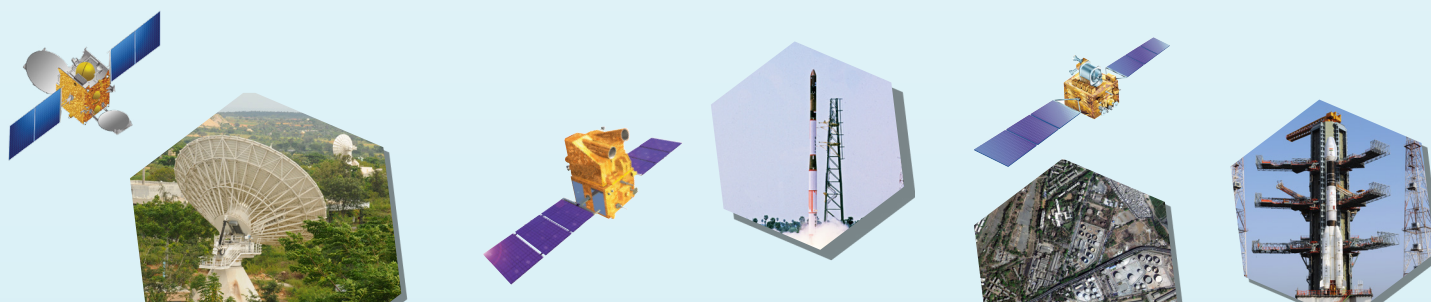

# Transmit-Receive Module

Space Applications Centre of ISRO has developed a transmit receive (TR) module which is very useful as both transmit and receive chains are accommodated in a single small housing for achieving higher gain. This MMIC based TR module is flown in Radar Imaging Satellite (RISAT- 1). It is a building block for radars and finds its applications in weather radar, ground based radar etc. Each TR Module consists of a low power TR switch to select either of the transmit or receive paths. It has a weight of 420 gms.

ISRO offers to license this technology of Transmit Receive Module to industries with adequate experience and facilities. Enterprises interested in obtaining knowhow may write giving details of their present activities, infrastructure and facilities to us.

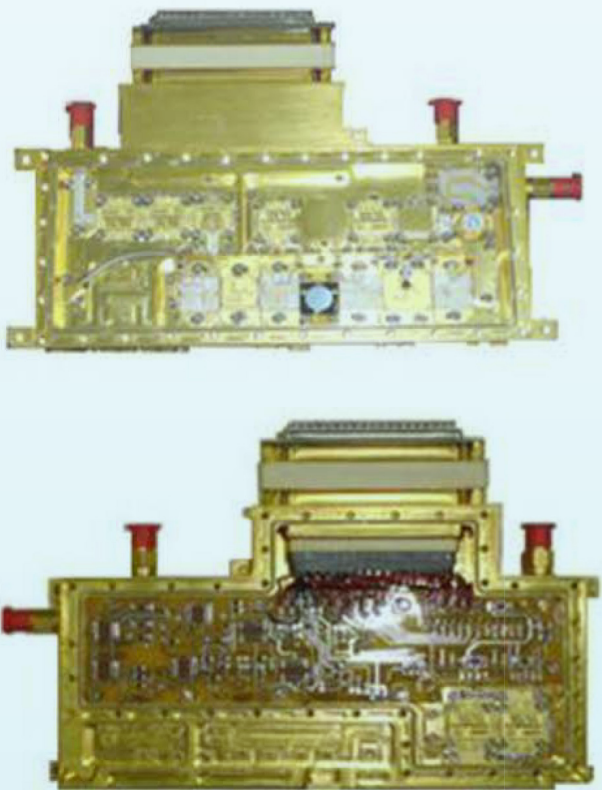

Parameter	Specifications
Frequency	5350 GHz
Bandwidth	225 MHz
Phase Control	6 bits, 360 deg range/ 5.625 deg step
Gain Control	6 bits, 31.5 dB range/ 0.5 dB step
Coupling of Coupler	20 dB
<b>Transmit Path Characteristics</b>	
Input Power	-10 dBm
Peak Output Power	10W
Transmit Pulse Duration	20µs, 10% duty
<b>Receive Path Characteristics</b>	
Noise Figure	4 dB
Gain @ 0 dB Attenuation	30 dB
SPST Isolation	35 dB

## Technology Transfer from ISRO

ISRO is willing to offer the knowhow of this technology to suitable entrepreneurs / industries in India. Capable manufacturing industries interested in acquiring this knowhow may write with details of their present activities, requirements and plans for implementation, infrastructure and technical expertise available with them, their own market assessment, if any, and plans for diversification to the address given below:

NewSpace India Limited (NSIL)  
Email: [contact-nsil@isro.gov.in](mailto:contact-nsil@isro.gov.in)

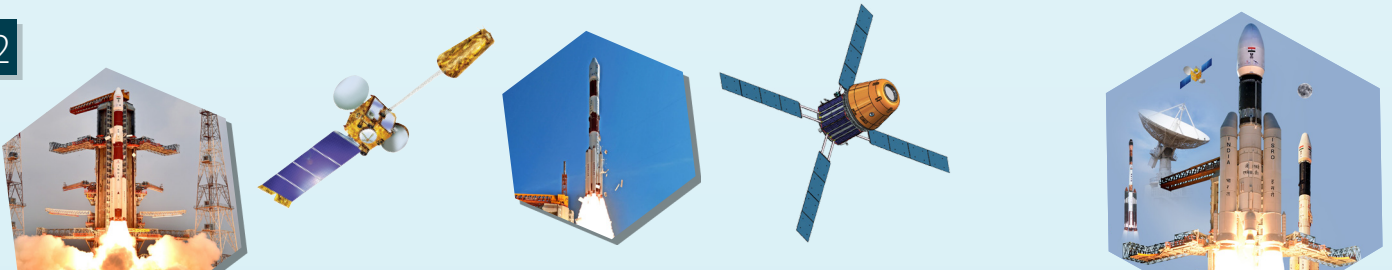

# Power Conditioning and Processing Unit

SAC has developed a Power Conditioning and Processing Unit (PCPU) for use in microwave remote sensing missions. PCPU is a very complex multi output dc - dc converter that delivers around 100W of peak power and around 10W of average power. Here, Planar magnetics is used for the first time which was realized using 18 and 16 layer PCBs.

## Salient Features of PCPU

- Powers a pair of V&H TR Modules and a TRC unit
- 10 outputs: 8 pulsed+ 2 continuous
- 59W pulse output power
- 9.1W average output power
- High BW pulse modulators for fast rise & fall times on pulsed outputs
- In-built EMI filter isolates the satellite bus from the pulsed load transients

## Technological Features

- Thick film technology
- SMT technology
- Planar Magnetics
- Magnesium alloy for weight reduction
- Hybrid Micro- Circuits

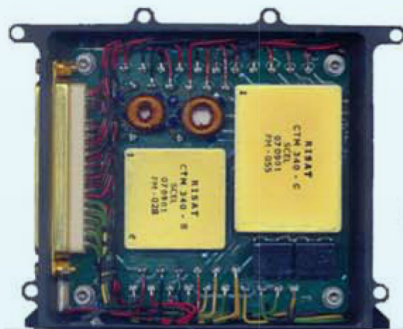

ISRO offers to license this technology of PCPU to industries with adequate experience and facilities. Enterprises interested in obtaining knowhow may write giving details of their present activities, infrastructure and facilities to us.

NewSpace India Limited (NSIL)  
Email: [contact-nsil@isro.gov.in](mailto:contact-nsil@isro.gov.in)

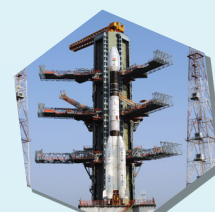
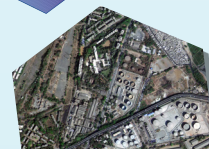
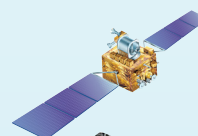
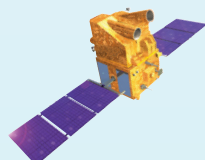
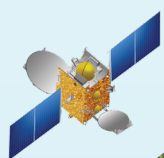

# L-BAND True Time Delay Phase Shifter

Space Applications Centre of ISRO has developed an integrated 6-bit GaAs MMIC digital phase shifter featuring two MMIC dies catering to 1024 ps delay requirement. It operates at 1.25 GHz with 250 MHz bandwidth, providing 1024ps of delay coverage, with a resolution of 16 ps. It features very low RMS delay error of 8 ps. This TTD Phase shifter requires an external driver circuit and works on negative control logic of 0/-5V. It is internally matched to 50 ohms and is ideal for integration into Multi chip Modules (MCMs) due to its small size.

## Typical Applications

- EW Receivers
- Weather & Military ultra wideband Radars
- Beam Forming Modules

## Salient Features

- 6 bit TTD-Phase Shifter
- Wide Dynamic range: 1024 ps
- Fine Resolution: 16 ps
- Novel Topology of self switched band pass network for 256 ps delay bit
- Novel topology of compensated network for 512 ps delay bit

LSB1-LSB5 bit

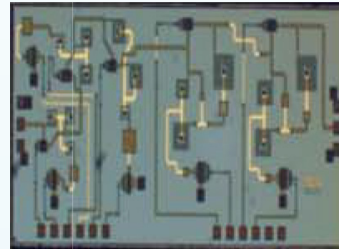

5.5 mm X 2.3 mm

LSB6 Bit

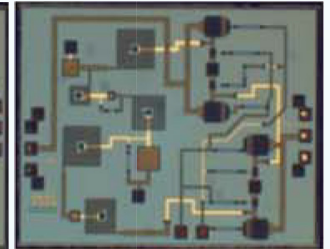

3 mm X 2.3 mm

## Interface Diagram

Switch Control from external TTL-MESFET driver  
-5V = OFF state 0V = ON state

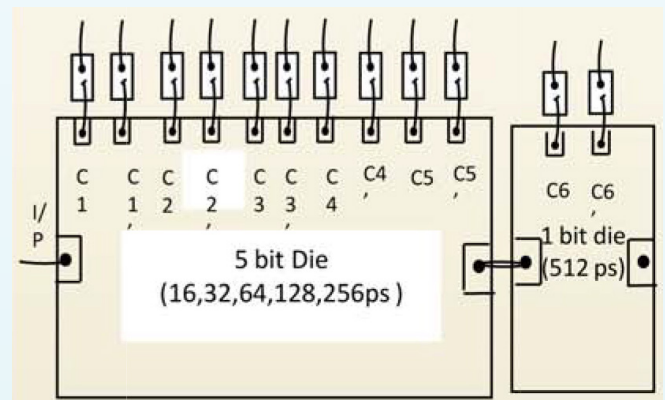

Frequency (Ghz)	Max. Insertion Loss (dB)	Delay Range (ps)	I/O Return Loass Max. (dB)	Max. RMS Error (ps)	Control Input
1.25 ± 0.125	15	16 to 1024	12	8	0/-5V

ISRO offers to license this technology of L band true time delay phase shifter to industries with adequate experience and facilities. Enterprises interested in obtaining knowhow may write giving details of their present activities, infrastructure and facilities to us.

NewSpace India Limited (NSIL)

Email: [contact-nsil@isro.gov.in](mailto:contact-nsil@isro.gov.in)

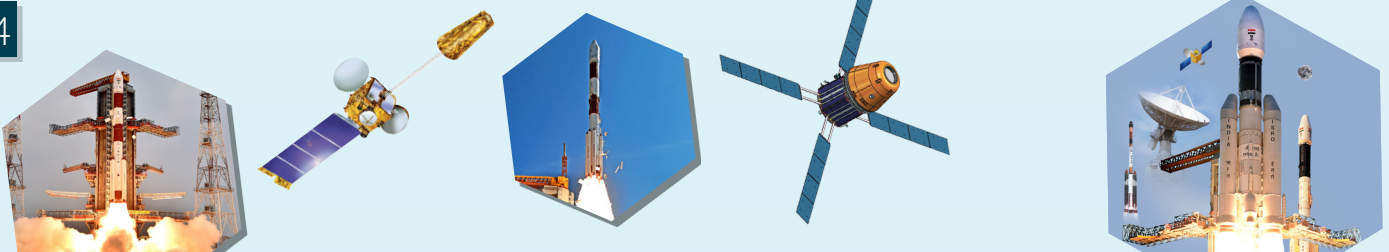

# Ka Band 5W Solid State Power Amplifier

5 watt Ka-Band (29.6 30.2 GHz) SSPA was successfully designed, developed and integrated in the ground terminal of GSAT-4 project. The technology has also been transferred to the Industry (ASTRA MW).

## Salient Features of SSPA

The MMIC based SSPA at Ka-Band (30 GHz) with 5 Watt of output power is first time developed in SAC, India. It makes use of indigenously developed waveguide based extremely low loss symmetric 3 dB Quadrature coupler to derive the 5 Watt of output power

## Major Specifications:

Frequency Range : 29.6 - 30.2 GHz

Output Power : 37 dBm

Small Signal Gain : 40 dB

Gain Flatness: :  $\pm 0.6$

Return loss : > 17 dB

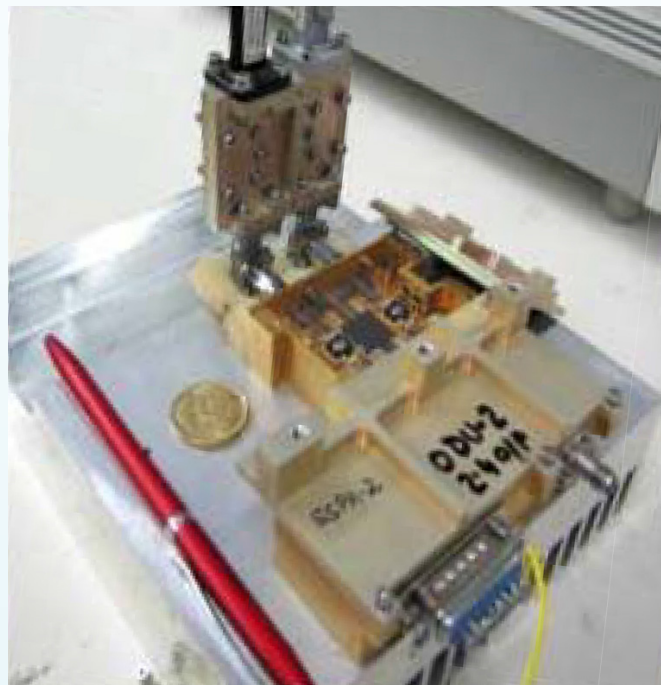

## Technology Transfer from ISRO

ISRO is willing to offer the knowhow of this technology to suitable entrepreneurs / industries in India. Capable manufacturing industries interested in acquiring this knowhow may write with details of their present activities, requirements and plans for implementation, infrastructure and technical expertise available with them, their own market assessment, if any, and plans for diversification to the address given below:

NewSpace India Limited (NSIL)

Email: [contact-nsil@isro.gov.in](mailto:contact-nsil@isro.gov.in)

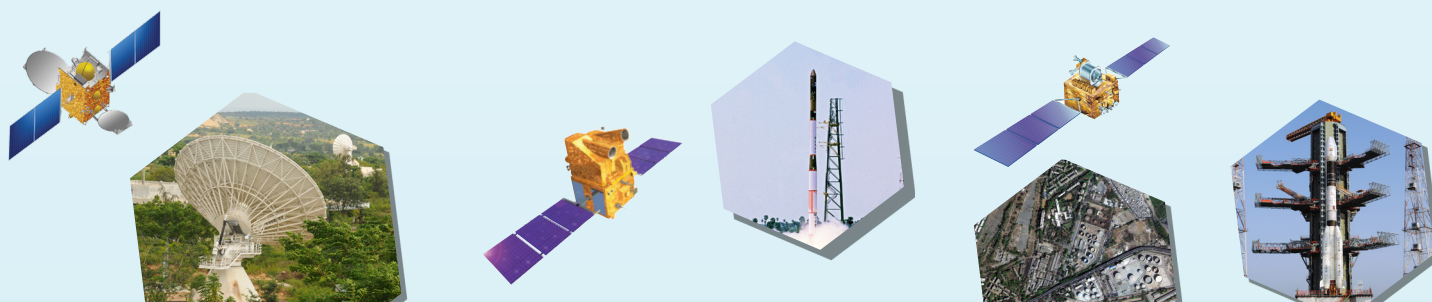

# 15W C Band Solid State Power Amplifier

The GEOSAT program of ISRO is conceived to address the nation's growing need for satellite based connectivity for broadcast, communications and networking applications. The growing demand for bandwidth to support such applications is calling for a large number of transponders to be deployed in the coming years.

Solid State Power Amplifiers (SSPAs) are used extensively in such transponders. Space Applications Centre (SAC), ISRO has developed and qualified a design for normal C band operation, tailored to meet this requirement on board GEOSAT satellites. ISRO invites interested and capable parties to whom this technology can be transferred. Under this arrangement, qualified vendors will be enabled to undertake fabrication, testing, optimization and delivery of the RF assemblies required in these SSPAs. The SSPA consists of RF Assembly and an Electronic Power Conditioner [EPC] Assembly.

## Attenuators

The SSPA has two PIN attenuator circuits. One is a two section commandable attenuator providing up to 24 dB of attenuation for on-board gain control. The second attenuator is used for compensation of gain variation against temperature. Each attenuator section employs 3 dB Lange couplers with two PIN diodes.

The commandable attenuator is externally controlled through serial commands. These commands are processed within the SSPA using a decoder comprising integrated circuits CD4050, CD40174, CD4015, CD40106 and CD4051. This decoder, along with biasing arrangements for all devices, is implemented on a PCB which is housed in a separate section of the RF assembly. The temperature compensation network is also included on this card.

## RF Amplifier

The RF Assembly consists of low, medium and high power amplifier stages along with two attenuators.



The nominal RF output power of the SSPA is 15 Watts (41.8 dBm) in the specified operating frequency band. Nine amplifier stages provide the required 86 dB gain. The small signal stages employ five CFY25-20 devices in a 3 + 2 chain. These small signal stages will drive the medium power stages based on MGF2407 & MGF2430. All these stages are housed in one section of the RF package. The output of this section (i.e. small and medium power stages) is fed to the Power Amplifier section of the same housing, via co-axial cable. The Power Section houses the MGF38V and MGF44V devices, the latter being a 25 Watt output device. The space between the low power and high power sections is occupied by interconnections and harnessing.

## Technology Transfer from ISRO

ISRO is willing to offer the knowhow of this technology to suitable entrepreneurs / industries in India. Capable manufacturing industries interested in acquiring this knowhow may write with details of their present activities, requirements and plans for implementation, infrastructure and technical expertise available with them, their own market assessment, if any, and plans for diversification to the address given below:

NewSpace India Limited (NSIL)

Email: [contact-nsil@isro.gov.in](mailto:contact-nsil@isro.gov.in)

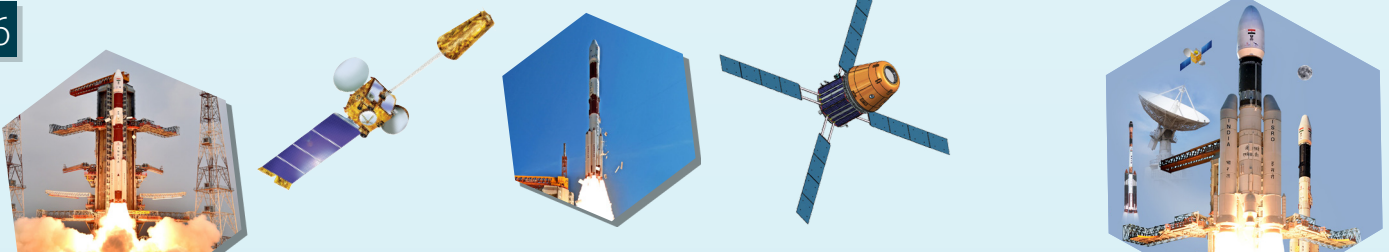

# C Band Active Radar Calibrator

SAC has developed a C band active radar calibrator for calibration of microwave imaging sensors. It is a ground based equipment developed indigenously.



ISRO offers to license this technology of Active Radar Calibrator to industries with adequate experience and facilities. Enterprises interested in obtaining knowhow may write giving details of their present activities, infrastructure and facilities to us.

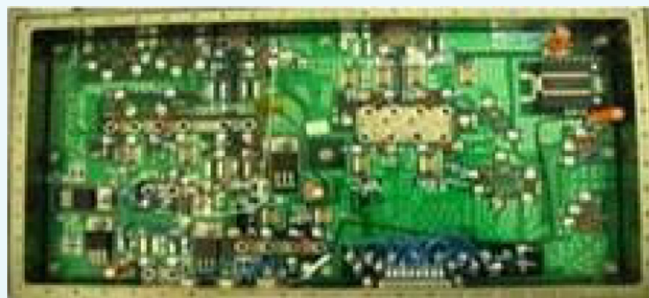
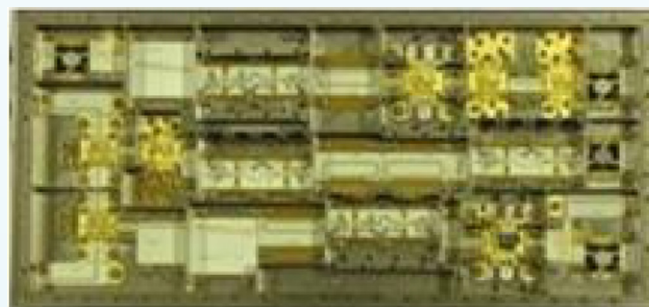

## Features :

- Can calibrate individual Like and Cross-Polarised C-band SAR Channels; W, HH, VH, HV & Circular Polarisation using two ARC Rxs.
- Dual Polarized broadband (7%) multilayer microstrip antenna of 23 dB gain and cross polarization better than -40 dB.
- Antenna protected by radome using inverted patch.
- Receiver Input Signal range: -25 to -60 dBm, Max Tx signal: +20 dBm.
- Each Channel contains Selectable Gain with Digital control (Step: 1dB) & 6 bit Digital Phase Control in steps of 5.625 deg.

## Technology Transfer from ISRO

ISRO is willing to offer the knowhow of this technology to suitable entrepreneurs / industries in India. Capable manufacturing industries interested in acquiring this knowhow may write with details of their present activities, requirements and plans for implementation, infrastructure and technical expertise available with them, their own market assessment, if any, and plans for diversification to the address given below:

NewSpace India Limited (NSIL)

Email: [contact-nsil@isro.gov.in](mailto:contact-nsil@isro.gov.in)

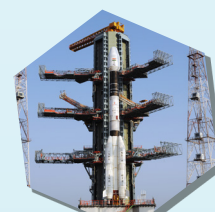
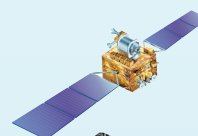
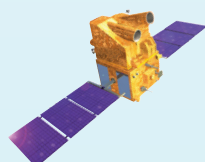
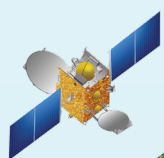

# Miniaturised High Frequency DC DC Converter

Indian Space Research Organisation (ISRO) at its Vikram Sarabhai Space Centre (VSSC) has developed a Miniaturised, High Frequency, Surface Mount Technology (SMT) based DC DC Converter. These converters are designed for aerospace applications and can also be used for commercial/Industrial applications.



SMT DC DC converters have usage heritage in all ISRO's launch vehicles programme and orbital platform experiments. These DC-DC converter modules can meet

the environments of aerospace applications and can withstand Vibration test, Shock test, Humidity test, Temperature soak tests. The converters are based on fixed frequency single ended forward topology with magnetic feedback and have an internal built in EMI filter to meet the conducted emissions and conducted susceptibility requirements of MIL-STD-461C. These converters are production friendly as these are based on surface mount technology. Thermal management is provided by conductive heat transfer and by using potting compounds. Design is tested at an ambient of 70°C for 320 hours.

## Features

- Input voltage range 26 V to 32 V<sub>DC</sub>  
*Note: Can be modified to 24V-40 V<sub>DC</sub> or 12V- 24V<sub>DC</sub>*
  - with minor modification
- Built in EMI filter to meet MIL STD 461 C
- Voltage feedforward topology

- Single and dual output models
- Up to 50 watts of output power
- Indefinite short circuit protection
- +5V/1.8A, +5.25V/1.8A, +7.5V/1.2A, +10V/2.5A, +15V/1A, +28V/0.9A, ±5V/0.5A & ±15V/0.5A
- Without Short circuit protection
  - +5V/1.8A, +5.25V/1.8A, +7.5V/1.2A, +10V/2.8A, +15V/1A, +24V/1.5A, +28V/1A, +28V/1.8A, +32V/1A, ±5V/1A & ±15V/0.5A

*Note : Can be modified to any other voltage levels (from 5V- 32V) by minor design modification*

- Fully isolated, magnetically coupled feedback
- Isolation resistance : 100MΩ @ 50V DC
- Fixed High Frequency switching
- Efficiency from 70-80%
- Typical output ripple is 50 mV
- Load regulation < 1%
- Line regulation < 0.2%
- Case size : 97 mm × 44 mm × 24.5 mm (Flanged)
- Weight : 125 gms

## Technology transfer from ISRO

ISRO is willing to offer the knowhow of this technology to suitable entrepreneurs/industries in India. Capable manufacturing industries interested in acquiring this knowhow may write with details of their present activities, requirements and plans for implementation, infrastructure and technical expertise available with them, their own market assessment, if any, and plans for diversification to the address given below.

NewSpace India Limited (NSIL)

Email: [contact-nsil@isro.gov.in](mailto:contact-nsil@isro.gov.in)

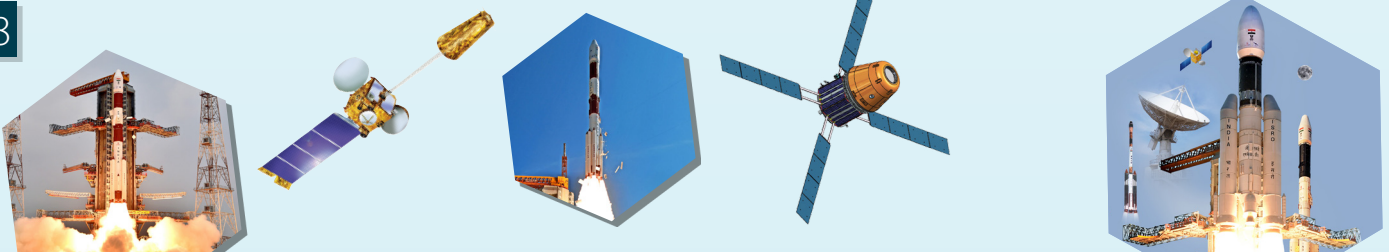



# Supercapacitors

Indian Space Research Organisation (ISRO) at its Vikram Sarabhai Space Centre (VSSC) has developed the technology for processing Supercapacitors (2.5 V) of varying capacitance values viz., 5 F, 120 F, 350 F and 500 F for catering to specific applications related to Space and Societal needs.

Supercapacitors form a new class of electrochemical energy storage device poised to play an important role providing very high electric power boost demanded by applications. The beauty of this electrochemical component "Supercapacitor" is that it can be charged in seconds rather than hours; discharged as very high pulse current over million recharge cycles. Unlike batteries, it is environment friendly, maintenance free, efficiency level 98%, can operate at wide temperature range of - 40°C to + 70°C, it covers life span of 15 years without any quick ageing.

**Operation and design:** Conventional capacitor stores the electrical energy between two parallel plates by charge separation under the influence of electric field, whereas in super capacitor the charge is stored in an electrical double layer between electrode-electrolyte interfaces through oppositely charged ion adsorption in the interface manifested within Angstrom ( $\text{\AA}$ ) distance. Basic materials considered for processing such electrodes exhibit very large surface area (1500 – 3000  $\text{m}^2/\text{g}$ ), paving way to achieve greater specific capacitance values (1-1000 F) along with high specific power. By this way, Super capacitors emerge to fill up the gap between conventional dielectric capacitors (for high power delivery) and batteries (for high energy supply). In addition, Supercapacitors are similar to batteries in design and configuration, but undergo charge and discharge operations continuously without significant degradation that batteries suffer.

**Advantages:** Supercapacitors can complement a primary energy source such as an internal combustion engine, fuel cell or a battery which cannot repeatedly provide quick bursts of high power. Using hybrid energy/power systems consisting of supercapacitors and battery in parallel, repeated pulse power needs can be met with, in which supercapacitor handles the peak power delivery while the battery provides sustained energy for load and recharging the supercapacitor. There will be significant advantage due to reduction of mass and size of battery as well as improved battery life and thus cost effective.



## Applications:

**Aero Space:** Delivery of peak/high pulse current for ignition systems, separation systems, actuators etc., Such high power capability envisages high power communication during interplanetary missions as well as in conventional electronics.

**Societal:** Applications include automotive industry, hybrid transportation systems, grid stabilization, utility vehicles and rail-system power models. Supercapacitors could play an interesting role in consumer electronics powering electronic gadgets

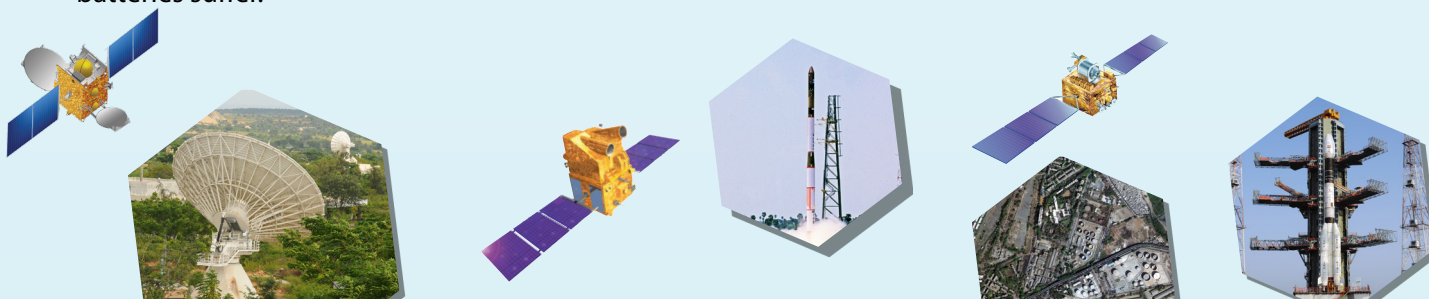

and cell phones to squeeze out extra energy and help a cell phone last longer.

### Salient features of the systems (500 F typical)

1	Rated Capacitance	500 F
2	Maximum ESR DC, initial	2.5 mΩ
3	Rated Voltage	2.5 V
4	Absolute Maximum Voltage	2.7 V
5	Absolute Maximum Current	1000 A
6	Leakage Current at 25°C	5 mA
7	Maximum Stored Energy, (Wh/kg)	> 5.5
8	Specific Power, $p_{max}$	5.4 kW/kg
9	Short Circuit Current, typical (A)	600-700 A
10	Operating Temperature	-20 to 65°C

**Currently, VSSC has established the technology in lab level with equipment such as electrode preparation, dry assembly and testing. Interested parties may scale-up the technology as per their market demands.**

### Technology Transfer from ISRO

ISRO is willing to offer the knowhow of this technology to suitable entrepreneurs / industries in India. Capable manufacturing industries interested in acquiring this knowhow may write with details of their present activities, requirements and plans for implementation, infrastructure and technical expertise available with them, their own market assessment, if any, and plans for diversification to the address given below:

NewSpace India Limited (NSIL)  
Email: [contact-nsil@isro.gov.in](mailto:contact-nsil@isro.gov.in)

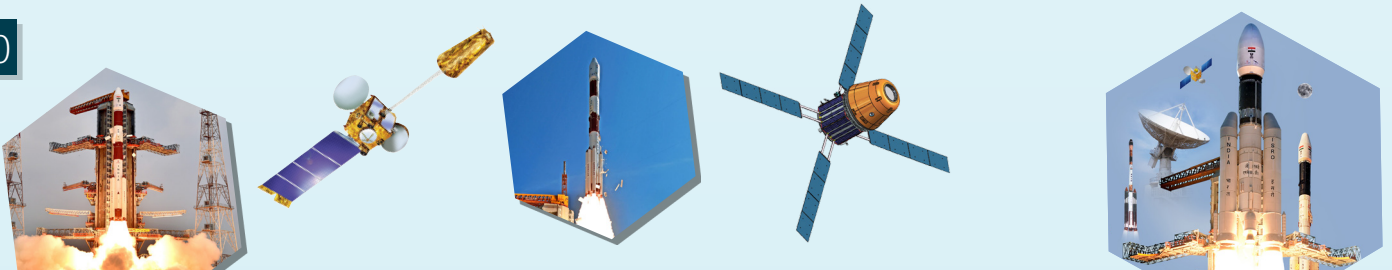

# Ultrasonic Burning Rate Measurement System (UBRMS)

Ultrasonic Burning Rate (UBR) measurement system is a technique developed by VSSC for measuring the burning rate of solid propellants. The system employs ultrasound pulses to measure the thickness of the burning solid propellant.

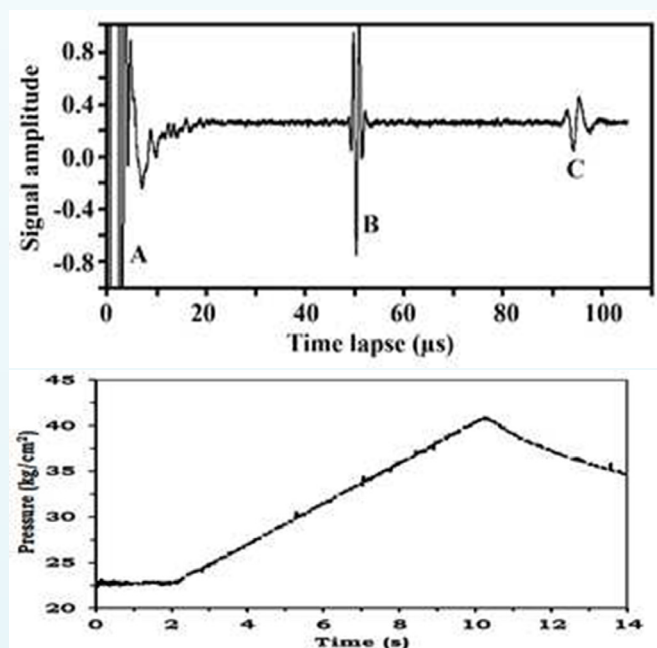

The UBR measurement system consists of three units:

1. **Hardware unit:** The hardware unit of the system is a test setup in which the propellant specimen is burned.
2. **Electronic unit:** The electronic unit consists of
  - a) ultrasonic transducer based electronics capable of acquiring data at very high sampling rate,
  - b) data acquisition electronics to process the sensor data,
  - c) computer to store/analyse the acquired test data, and
  - d) ultrasonic and pressure transducers.
3. **Processing Software:** The entire operation of the UBR measurement system including electronic

unit works upon a set of user-friendly graphical software packages. Commercially available data acquisition cards for processing of ultrasonic sensors can also be used, for which the software for initialization and data acquisition has to be developed separately.

## Application:

The UBR measurement system is used for measuring the burning rate of solid rocket propellant. This system can be set up in a small space for routine measurements in propellant plants or for research purposes in laboratories. The system is safer, has better measurement accuracy, and requires low manpower with considerable savings in cost and time compared to the conventional method of propellant burning rate determination.

## Technology Transfer from ISRO

ISRO is willing to offer the knowhow of this technology to suitable entrepreneurs/industries/institutions/organizations in India. Capable parties interested in acquiring this know-how, may write with details of their present activities, requirements and plans for implementation, infrastructure and technical expertise available with them, their own market assessment, if any, and plans for diversification to the address given below.

NewSpace India Limited (NSIL)

Email: [contact-nsil@isro.gov.in](mailto:contact-nsil@isro.gov.in)

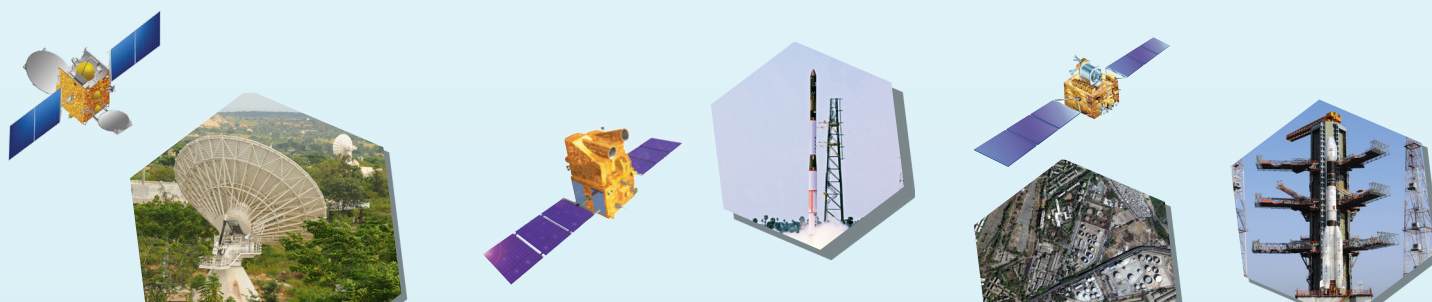

# MEMS Acoustic Sensor

MEMS Acoustic sensor is used to monitor the Acoustic Levels generated during the launch of a satellite launch vehicle. It is a piezoelectric, MEMS sensor with built-in electronics. MEMS technology enables miniature devices to be precision batch fabricated. The sensors work in harsh environments and can withstand Vibration test, Shock test, Humidity test, Temperature soak tests. It is the first indigenously developed MEMS sensor flight-tested in an Indian Launch Vehicle and has operational heritage of 12 successive PSLV flights.

## Salient Features

- Bulk micro machined silicon diaphragm with Piezoelectric sense layer on Silicon
- Range - 100 to 180 dB (2 Pa to 20 KPa)
- Frequency Range - 31.5 Hz to 6.3 KHz in 1/3<sup>rd</sup> Octave centre frequencies
- Sensitivity- 150 to 200 uV/Pa
- Amplitude Linearity - 2 dB
- Frequency response - 3 dB
- Weight-120 grams
- Operating temperature range - -40 to +125°C
- System design done at ASCD/AVIONICS/VSSC



- Process design & fabrication at CEERI, Pilani
- Built in electronics and hence smart
- Elimination of external signal conditioners
- Reduction in cabling and ease of integration

## Technology Transfer from ISRO

ISRO is willing to offer the knowhow of this technology to suitable entrepreneurs / industries in India. Capable manufacturing industries interested in acquiring this knowhow may write with details of their present activities, requirements and plans for implementation, infrastructure and technical expertise available with them, their own market assessment, if any, and plans for diversification to the address given below:

NewSpace India Limited (NSIL)

Email: [contact-nsil@isro.gov.in](mailto:contact-nsil@isro.gov.in)

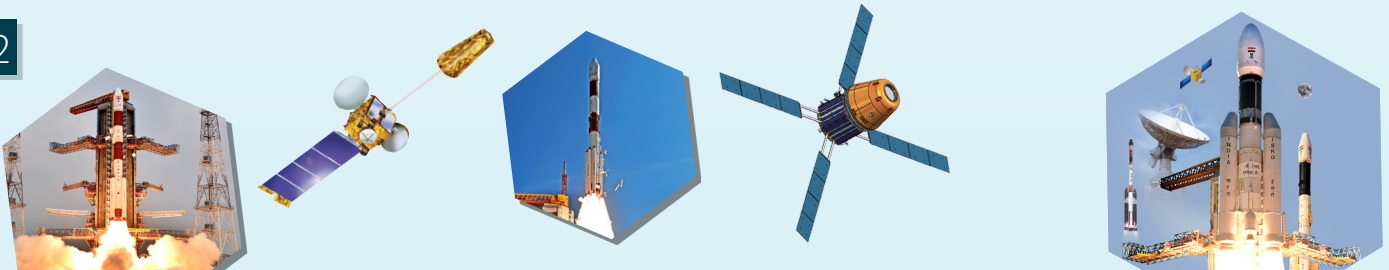

# Thermal Sensors

Indian Space Research Organisation at its Vikram Sarabhai Space Centre (VSSC), Thiruvananthapuram has developed thin foil heat flux sensors (Gardon Gauge) and temperature probes. They have applications in a variety of heat measurements like radiative and convective heat flux measurement for short durations in flight, aerodynamic heat transfer measurements on moving bodies during flight, plume heat flux measurement at nozzle exhaust, flame temperature measurement at nozzle exit, hot gas temperature measurement inside combustion chambers etc.

VSSC is willing to offer the process know-how of processing these sensors to eligible interested parties who are working in the domain of heat transfer/sensors.

Interested entrepreneurs are requested to contact the address given below with all relevant particulars regarding their line of current activity, infrastructure available, market assessment of the product, financial arrangements made, turn over and sales of their products for the past years and a copy of their latest annual report

## Technology Transfer from ISRO

ISRO is willing to offer the knowhow of this technology to suitable entrepreneurs / industries in India. Capable manufacturing industries interested in acquiring this knowhow may write with details of their present activities, requirements and plans for implementation, infrastructure and technical expertise available with them, their own market assessment, if any, and plans for diversification to the address given below:

NewSpace India Limited (NSIL)  
Email: [contact-nsil@isro.gov.in](mailto:contact-nsil@isro.gov.in)

Sensor Name	Measured parameter	Range	Sensor output at full range	over range	accuracy
Thin foil heat flux sensor (uncooled)	Heat flux	10 and 30 W/cm <sup>2</sup>	Linear output, 10 mV	25% of rated heat flux	±5%
Thin foil heat flux sensor (cooled)	Heat flux	10 and 30 W/cm <sup>2</sup>	Linear output, 10 mV	25% of rated heat flux	±5%
Gas Temperature probe	Temperature	77 to 2500K	75mV	-----	±2%

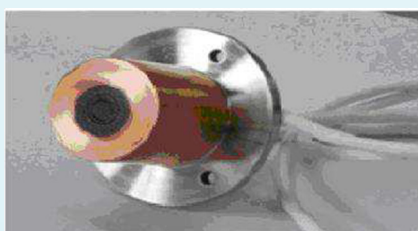

Fig1. Thin foil Heat Flux Sensor (Uncooled)

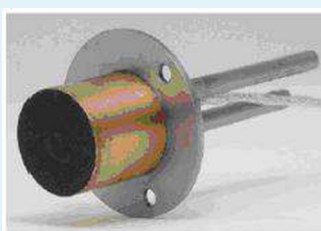
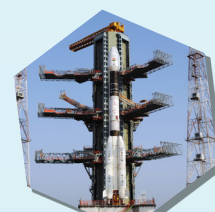
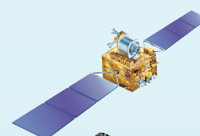
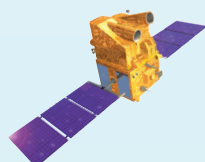
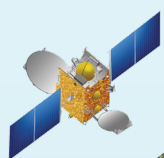

Fig2. Thin Foil Heat Flux Sensor (cooled)



Fig3. Gas Temperature probe



# TRISP (Triple Input Smart Power Supply)

Desktop PC equipped with inbuilt UPS functionality and direct solar interface, saving 65% power, is materialised using TRISP.

TRISP is an innovative power module with in-built UPS function to power Desktop PCs. The novel concept of TRISP can be adapted to any system which uses DC as its final power source and require power backup. With this configuration, during sunny days, a desktop PC consumes no power from the mains, whereas a conventional 1KVA UPS powered system consumes around 120 watts on an average.

## Features

- Eliminates UPS and replaces SMPS in Desktop PCs
- Utilizes one of the three power sources including non-conventional power ie, solar power, mains power, and battery power.
- Ensures seamless change over between solar, utility and battery sources

## Advantages

- 5 fold back up time compared to 1KVA UPS powered PC.
- Smartly uses green energy whenever it is available. Drastically reduces power line pollution.
- Power saving for 100000 PCs - around 1.5 million units per year (Rs.1.25 to 2 Cr).
- Mass production cost - one fourth cost of a 1KVA Online UPS.
- Ideal for use in remote settlements.
- Minimum maintenance, Better reliability and Safety
- Provision for powering DC input LCD/LED displays

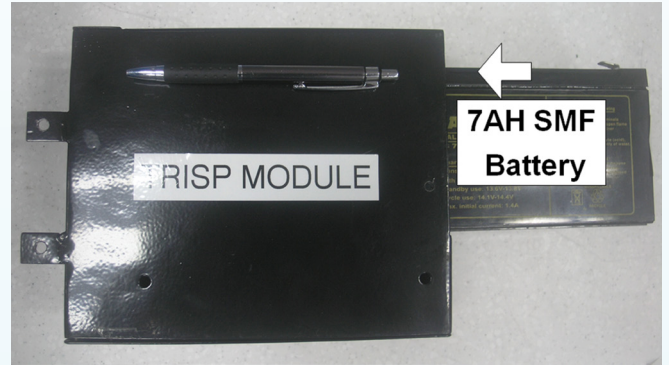

TRISP Module



TRISP POWERED PC

VSSC is willing to offer the technology of TRISP to eligible interested parties who are in the field of manufacturing of PCs. Incorporation of TRISP in to the next generation of PCs will be a boon to the industry. Manufacturers of PCs can adopt this technology to tap the potential of green energy and to have energy saving for the nation.

Manufacturers of power systems/modules can manufacture TRISP modules which can be used to convert conventional PCs to TRISP PCs.

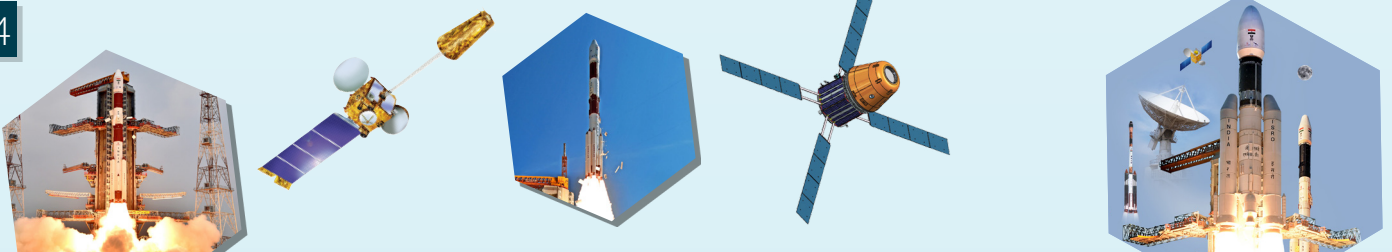

Interested entrepreneurs with the above mentioned background are requested to contact the address given below with all relevant particulars regarding their line of current activity, infrastructure available, market assessment of the product, financial arrangements made, turn over and sales of their products for the past years and a copy of their latest annual report.

## Technology Transfer from ISRO

ISRO is willing to offer the knowhow of this technology to suitable entrepreneurs / industries in India. Capable manufacturing industries interested in acquiring this knowhow may write with details of their present activities, requirements and plans for implementation, infrastructure and technical expertise available with them, their own market assessment, if any, and plans for diversification to the address given below:

NewSpace India Limited (NSIL)

Email: [contact-nsil@isro.gov.in](mailto:contact-nsil@isro.gov.in)

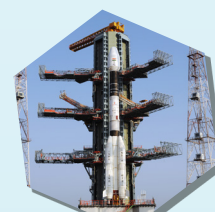
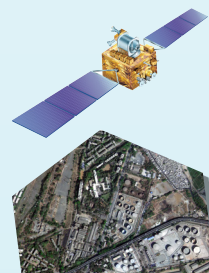
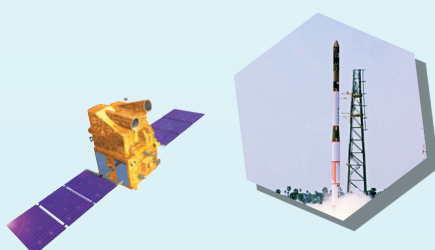

# Dual Polarized, S&X Band Mono Pulse Feed for Tracking Leo Satellites

A dual polarized S/X Band feed has been designed and developed to cater for data reception from remote sensing satellites, which adopts frequency re-use for data transmission. The development of feed has enhanced the data rate capability of ground station, which is essential to acquire high resolution imagery data from future missions. The feed comprises of S and X band radiating elements, polarizer, comparator for extracting Sum and Difference signals (AZ &EL). Instead of using conventional radiating elements such as four horns, five horns or multimode horn, dielectric rod radiating elements with high aperture efficiency, rotationally symmetric beams with low side lobe levels have been used. The feed is a single channel mono pulse tracking feed which provides high tracking accuracy to auto track the satellites

in X- Band and S-band. The dual polarized feed is capable of tracking in four modes, such as X-RHCP, X- LHCP, S-RHCP and S-LHCP, providing enormous flexibility to the ground station as it has the capability of switching to either of these modes.

The feed system has been integrated with a reflector of 7.5 m diameter in Cassegrain configuration and the system is made functional at National Remote Sensing Centre, ISRO to receive data from Low Earth Orbiting Earth Observation Satellites. The antenna & feed system provides a high G/T to receive data through LHCP and RHCP signals simultaneously. The dual polarized feed designed for frequency re-use facilitates high data rate signal reception, which otherwise is impossible, due to limited bandwidth available in X-Band signal reception.



*Integrated X-Band feed assembly*



*X-Band radiating element*

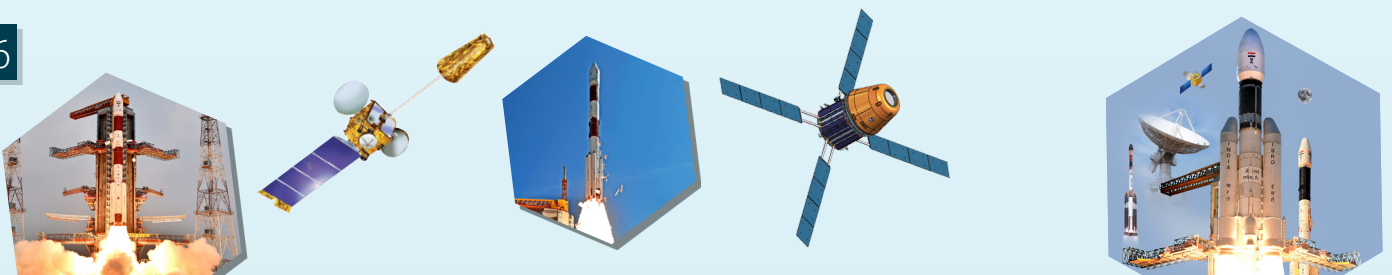



## Salient features:

- The feed, designed for mono pulse tracking, provides high tracking accuracy in X-band. The criticality of the tracking in X-band with very narrow beam width has been achieved.
- It is a composite feed, which performs tracking and receiving data in S&X-band. S-band feed contains circular helices and X-band contains dielectric rods.
- This dual polarized feed is capable of tracking in four modes, such as X-RHCP, X-LHCP, S- RHCP and S-LHCP. This provides the user great amount of flexibility as it has the capability of operating in either of these modes which one is receiving more signal strength or according to user's choice.
- Instead of using conventional four horns or five horns as feed element, here dielectric rod radiating elements with high aperture efficiency, rotationally symmetric beams with low side lobe levels, have been used.
- A septum polarizer is designed to separate LHCP and RHCP component and produce linear polarized

signal for the for comparator output. Septum polarizer exhibits good return loss and isolation between two ports, which receive orthogonal polarized components.

- S-band elements are composed of 20 turn tapered helix wound on a nylon former. Total eight helices are used four for RHCP and four for LHCP and capable of tracking in both orthogonal polarized mode.

## Application:

The feed system has been integrated with a reflector of 7.5 m diameter in Cassegrain configuration and the system is made functional at National Remote Sensing Centre, ISRO to receive data from Low Earth Orbiting Earth Observation Satellites. The antenna & feed system provides a high G/T to receive data through LHCP and RHCP signals simultaneously.

## Technology Transfer from ISRO

ISRO is willing to offer the knowhow of this technology to suitable entrepreneurs / industries in India. Capable manufacturing industries interested in acquiring this knowhow may write with details of their present activities, requirements and plans for implementation, infrastructure and technical expertise available with them, their own market assessment, if any, and plans for diversification to the address given below:

NewSpace India Limited (NSIL)

Email: [contact-nsil@isro.gov.in](mailto:contact-nsil@isro.gov.in)

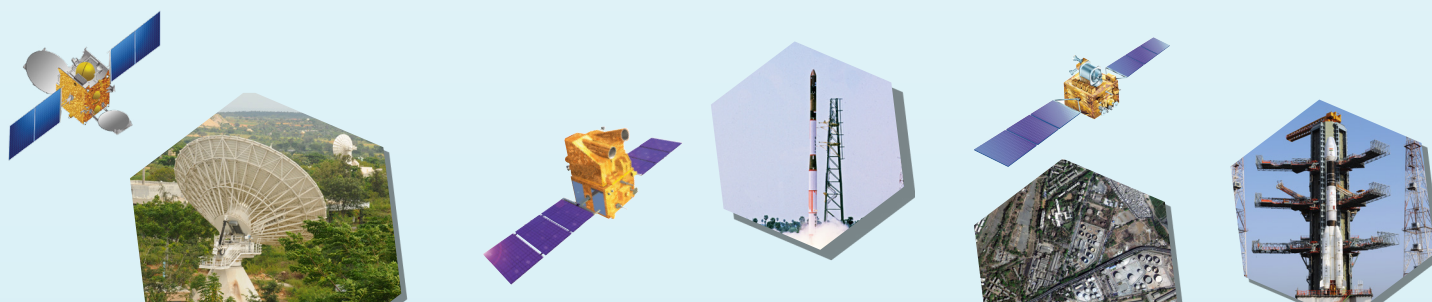

# Integrated Tracking System for Satellite Auto Track

Integrated Tracking System (ITS) has been designed, developed and made operational in remote sensing satellite ground station at NRSC. With the advent of this system, a new methodology has been adopted for deriving the tracking error information from single channel mono pulse tracking feed for precision satellite tracking. The Integrated Tracking System is a Digital Signal Processor based tracking system. The system amplitude demodulates the tracking IF signal consisting of tracking video and extracts Elevation and Azimuth DC errors. These error signals are then fed to servo control system for correcting the antenna position and track the satellite automatically. Earlier to this development, a total of 5 subsystems were used to realize all the functions required for satellite auto track. The ITS has brought out technology change, cost effectiveness and miniaturization in satellite ground station Design and Engineering.



Integrated Tracking System

## Application:

- Mono pulse analog signal processing is done in IF domain to estimate elevation and azimuth pointing errors and auto track the satellites. The analog RF electronics involved are dual

channel X-band Tracking Receivers for X-band, single channel S-Band Tracking receiver, Phase Shifter controller unit, scan code pulse generator and Tracking Demodulator Unit. All the above functions have been designed and realized in digital domain by using the state of the art technology of DSP and embedded systems as Integrated Tracking System.

## Salient features:

- Miniaturization obtained by this Integrated Tracking System.
- DSP, FPGA based technology.
- Double channel X-band tracking receiver(input:720MHz)-one LHCP, another RHCP.
- Single channel S-band tracking receiver (input:70MHz)
- Auto diversity in channel selection.
- Built in error de-modulator.
- Tracking chain optimization for phase shift.
- Scan code pulse generation.
- Multi mission tracking capability and storage of optimized parameter for various missions.
- Flexibility in changing the parameters for optimization purpose.

NewSpace India Limited (NSIL)

Email: [contact-nsil@isro.gov.in](mailto:contact-nsil@isro.gov.in)

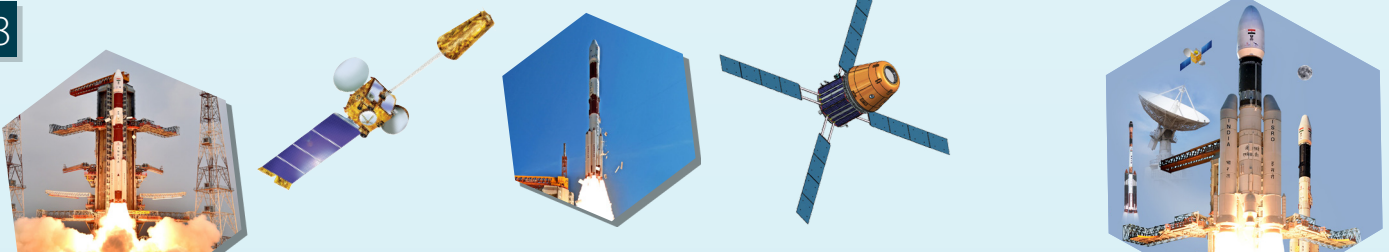

# Programmable IF Matrix

The main objective of the Programmable IF matrix is to facilitate total automation of the data reception chain including the RF signal routing path. The main function of the IF Switching Matrix is to facilitate the connectivity between any Antenna Terminal IF to any Demodulator.

Programmable IF matrix is designed for automatic operation by eliminating the manual intervention in the routing of various signals in the data reception chain. It eliminates the problems associated with manual patch panel like loose contact problems, mechanical wear and tear of the patch chords due to frequent operations, human errors etc., which in turn improves the reliability of the system while increasing the flexibility and reducing the complexity.

The in-house developed programmable IF matrix is an 8 x 10 switching matrix. It supports 4 input ports in the RHCP chain and another set of 4 input ports in the LHCP chain. The 4 RHCP Inputs can be routed as desired to a set of 4 demodulators and the inputs to another set of 4 demodulators can be routed as desired either from RHCP IF or LHCP IF. This Programmable IF matrix Unit also includes a Stand by port in both RHCP and LHCP signal path that acts as hot standby to any one of the 4 Terminal IFs. Programmable IF matrix also supports a monitoring port for all the input signals, this facilitates measurement of the input signal level

on a Spectrum Analyzer. The configuration of this unit is done using Front Panel Key Pad in local mode or with TCP/ IP or RS -232 in remote mode. The mode selection is done with the help of Local/ Remote switch provided on the Keypad on the front panel. In remote mode the Keypad option is also available to the user apart from the TCP/ IP or RS-232 interface.

## Specifications

Electrical	
Frequency Range	DC - 4GHz
Matrix Size	8 (Inputs) X 10 (Outputs)
Matrix Type	Non-Blocking
Insertion Loss	20 dB (aprox.)
Port to Port Isolation	> 90dB
VSWR	1.2 :1
Key Pad	3x3 Matrix type
LCD screen	240x128 Graphics LCD
Remote interface	Ethernet and RS-232

Environmental	
Operating Temperature	+5° C to +40° C
Storage Temperature	-10° C to +60° C

Power supply(external)	
Input Power Supply	230V +/-10% AC @ 50Hz +/-3Hz
Operating voltages	+5V, +15V and +24V

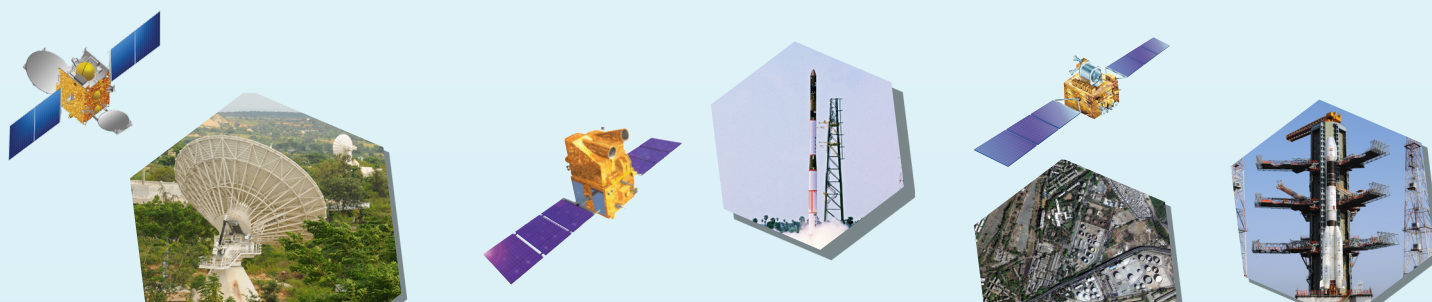

The functional block diagram of IF Switching Matrix with all the support interfaces is as shown below

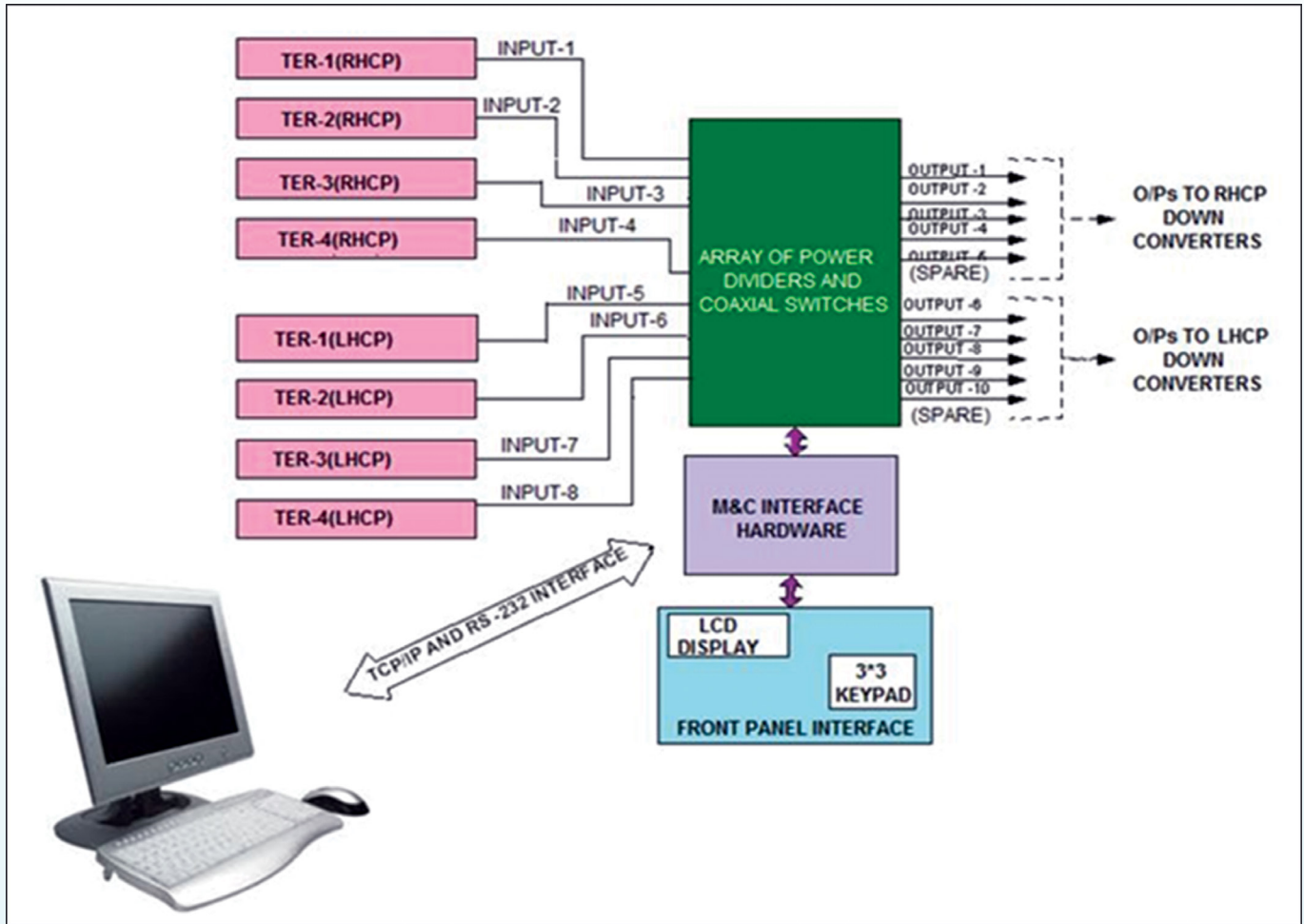

### Salient features:

- Facilitates Multi-port Matrix operation.
- Port-to-port isolation in DC-4GHz band is more than 100 dB.
- The Path length of all the signal paths has maintained constant with in the Programmable IF matrix. Hence, this mode of configuration has lesser Insertion loss and better VSWR.
- Loads default configuration after Power ON.

- User can modify the inputs any number of time s before configuring the signal path.
- Remote configuration through TCP/ IP or RS -232

### Applications

- Routing various RF signals in a multi-mission ground station.

NewSpace India Limited (NSIL)

Email: [contact-nsil@isro.gov.in](mailto:contact-nsil@isro.gov.in)



# Design & Development of FPGA Based Digital Demodulator

As different Satellites use different modulation schemes with variable data rates, in order to cater to the Multi-satellite data reception requirements of a ground station, it is necessary to have greater flexibility and programmability features embedded in the design of demodulators. The demodulation techniques for Binary/Quadrature Phase shift Keying (BPSK/ QPSK) are well established and understood when implemented with analog circuits. Recently, state-of-the-art digital technology allows Radio Frequency (RF) signals to be processed in the digital time domain. Modulated RF signals are digitally sampled and then demodulated in real-time using digital signal processing techniques implemented on FPGAs. Because of the usage of FPGAs, the design can have low power consumption, size and cost reduction. Furthermore, these digital demodulators can be reconfigured and upgraded to enhance the data rates in future.

The BPSK/ QPSK can be demodulate by different techniques such as squaring loop, Costas loop and

others in analog domain. The Costas loop technique has adopted for developing the demodulator in digital domain as in this the carrier recovery and data demodulation can be done simultaneously with block level design. The high data rate digital demodulator is planned to perform IF amplification, filtering and analog to digital conversion of the received IF signal followed by a Digital demodulator. The basic design strategy includes a configurable data rate BPSK/ QPSK demodulation with COSTAS loop circuitry utilizing the flexibility of FPGA implementation.

The IP core development for the demodulation including carrier recovery have been tested for the 8 Mbps BPSK and 42.4515Mbps QPSK as shown in the block diagram. The Prototype Hardware implementation has done using separate ADC and FPGA evaluation boards. The final realization of the demodulator logic has implemented on an integrated ADC -FPGA board.

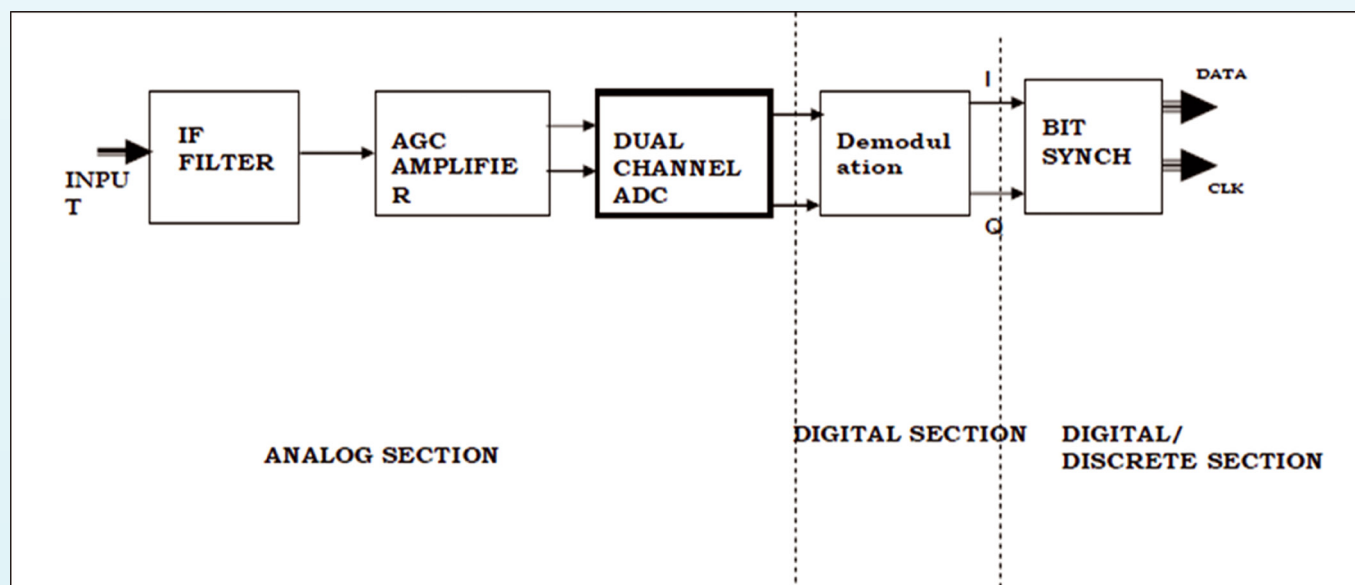

Block diagram of proposed demodulator

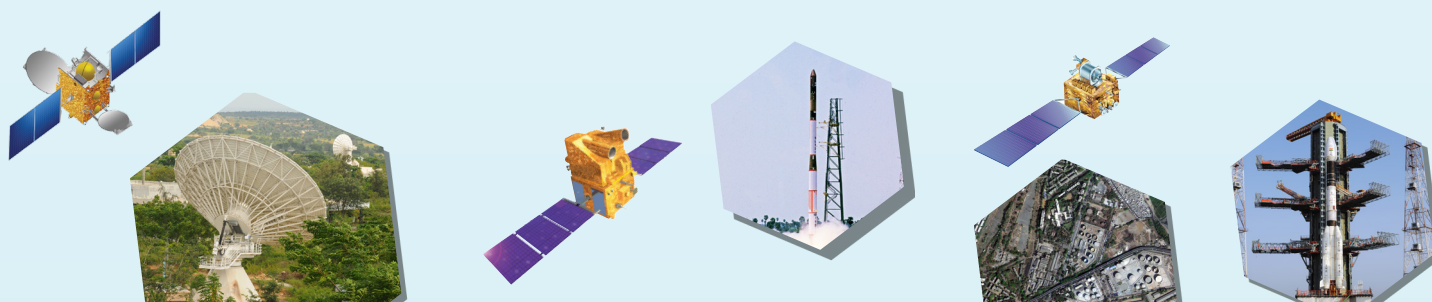

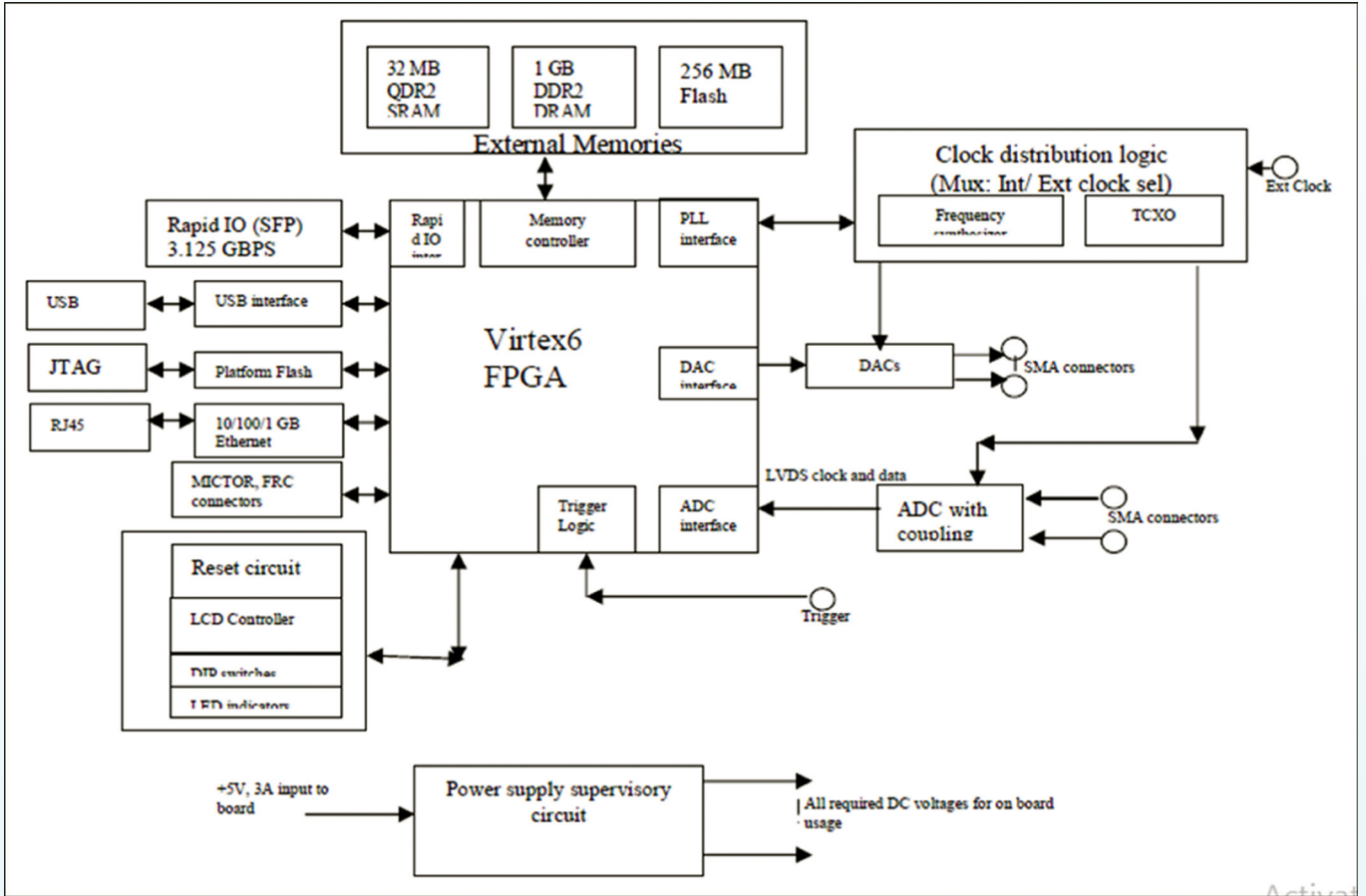

Block diagram of the final hardware with necessary interface circuitry

## Specifications

Sampling frequency (Fs)	125 MHz-250 MHz
Carrier frequency	30 MHz (BPSK), 70 MHz (BPSK/QPSK)
Data Rates (Fb)	8 MBPS (BPSK), 42.4515 MBPS (QPSK)
Low pass filters used	Raised Cosine FIR
FIR sampling frequency	(Fs/10) for 8 MBPS data rate and (Fs/ 4) for 42.4515 MBPS data rate
FIR Cut-off frequency	$1.5 \cdot (F_b/2)$ for BPSK and $1.5 \cdot (F_b/ 4)$ for QPSK
Loop filter used	1 <sup>st</sup> order Butter worth IIR
Loop filter cut-off frequency	200 KHz

## Conclusion:

The design of demodulator is proven for 8MBPS data rate BPSK demodulation and 42.4515MBPSQPSK demodulator and the test results are presented. The results show a promising inference for further scope of improvisation with respect to data rate and programmability.

## Applications

- High Data rate demodulation for remote sensing data reception system.

NewSpace India Limited (NSIL)

Email: [contact-nsil@isro.gov.in](mailto:contact-nsil@isro.gov.in)

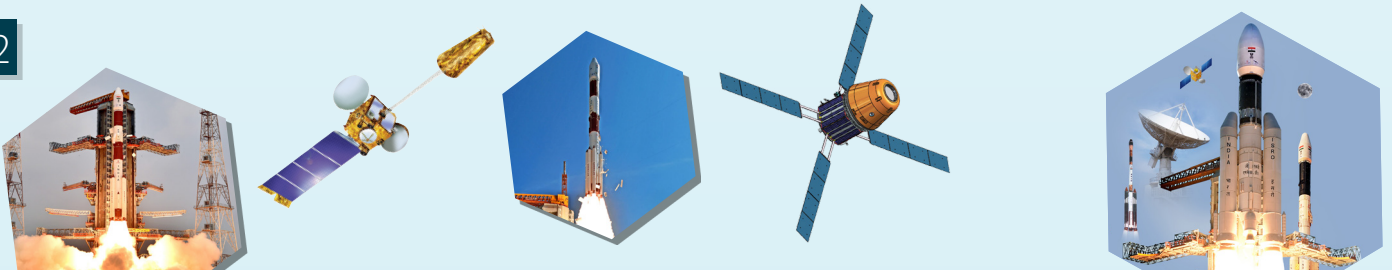

# Low Noise Amplifiers (LNAs) and RF Amplifiers for GNSS & VHF bands

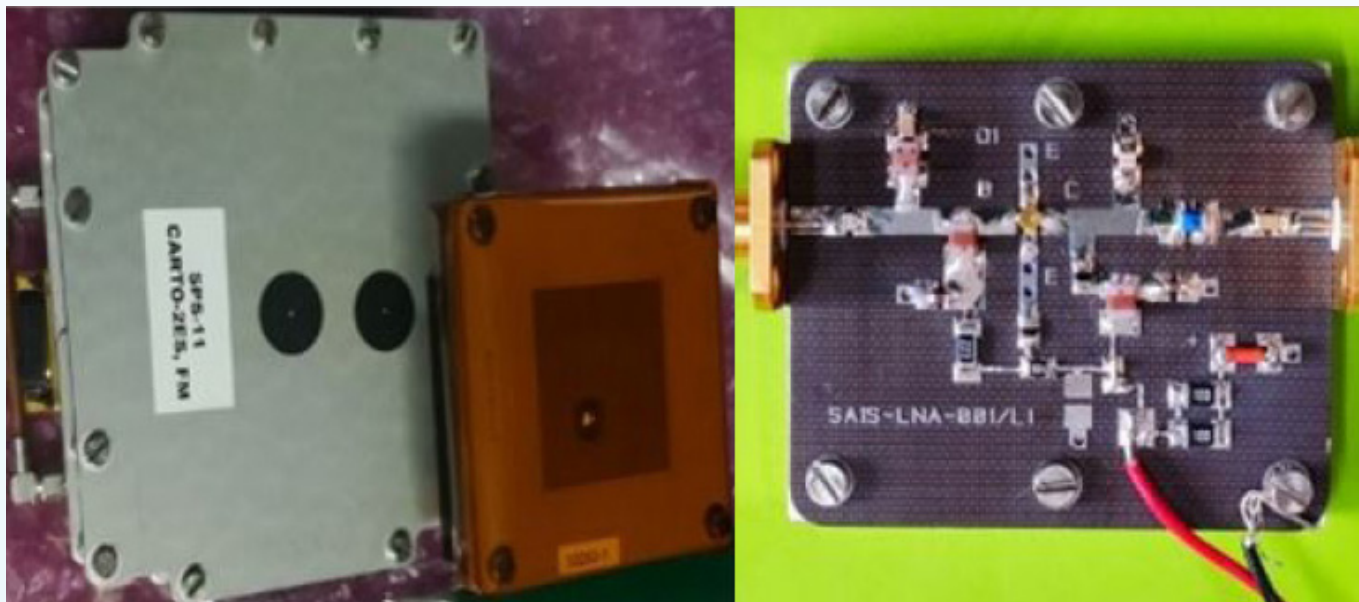

GNSS LNA & RF Amplifier

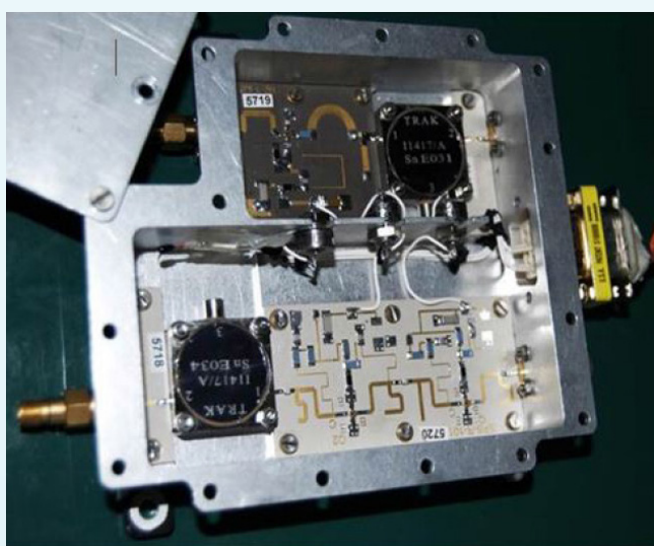

GNSS LNA & RF Amplifier

U R Rao Satellite Centre (URSC) of Indian Space Research Organisation (ISRO) has developed Low Noise Amplifiers and RF Amplifiers for GNSS & VHF bands application.

## Specifications:

- Low Noise Amplifier(LNAs):
  - GNSS LNAs realized in L1 & L5 bands based on hetero-junction & bi-polar transistor based designs offering excellent noise figure to amplify very weak signals.
  - VHF band LNAs support low noise amplification needs for receivers for automatic identification of ships.
- RF Amplifiers:
  - Low-power designs based on hetero junction & bi-polar transistors.
  - Developed for use in GNSS bands of L1 & L5 as well as VHF bands.

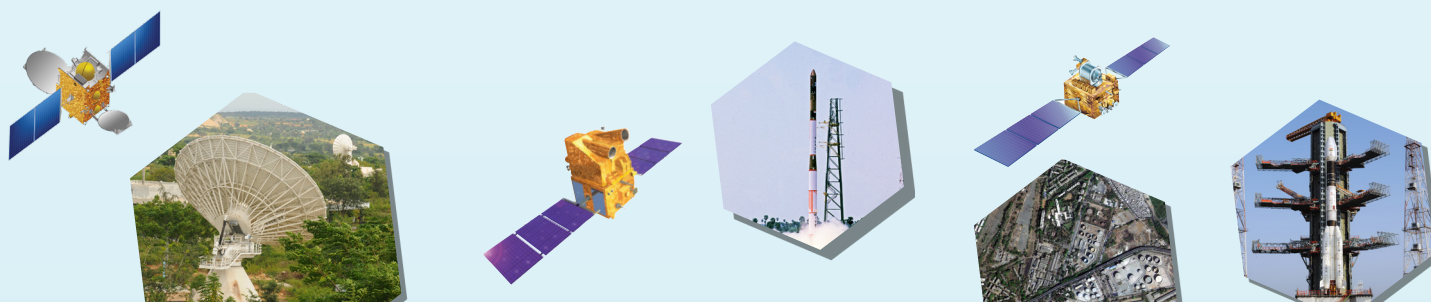

### Major Specifications

Low Noise Amplifiers	
Frequency bands	VHF (155-165MHz) GNSS L1 & L5
Gain	>20dB
Noise Figure	Better than 1db
RF Interface	SMA
Operating Voltage	5V

RF Amplifiers	
Frequency bands	VHF (155-165MHz) GNSS L1 & L5
Gain	>30dB
RF Interface	SMA
Operating Voltage	5V

### Technology Transfer from ISRO

ISRO is willing to offer the knowhow of this technology to suitable entrepreneurs / industries in India. Capable manufacturing industries interested in acquiring this knowhow may write with details of their present activities, requirements and plans for implementation, infrastructure and technical expertise available with them, their own market assessment, if any, and plans for diversification to the address given below:

NewSpace India Limited (NSIL)

Email: [contact-nsil@isro.gov.in](mailto:contact-nsil@isro.gov.in)





# E-Plane Filter

U R Rao Satellite Centre (URSC) of Indian Space Research Organisation (ISRO) has developed Low loss, high Q band pass filter with high power handling capability designed for data transmission applications in LEO satellites.

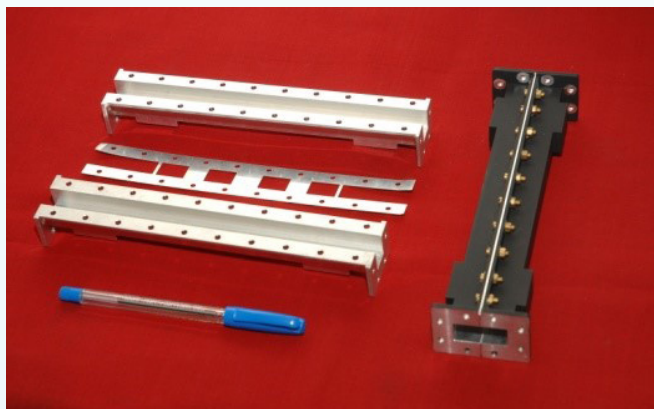

E-plane filter at X-band

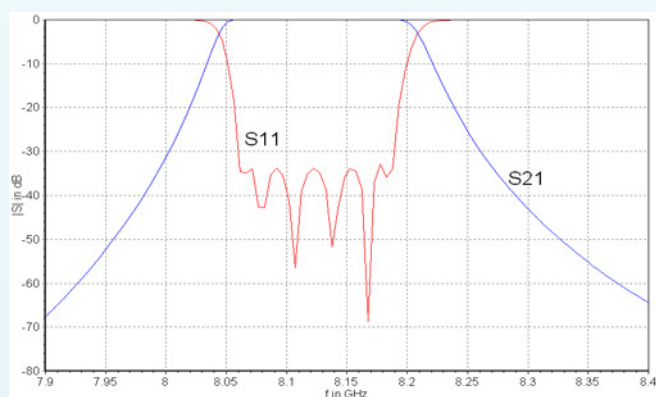

Measured response of E-plane Filter at X band

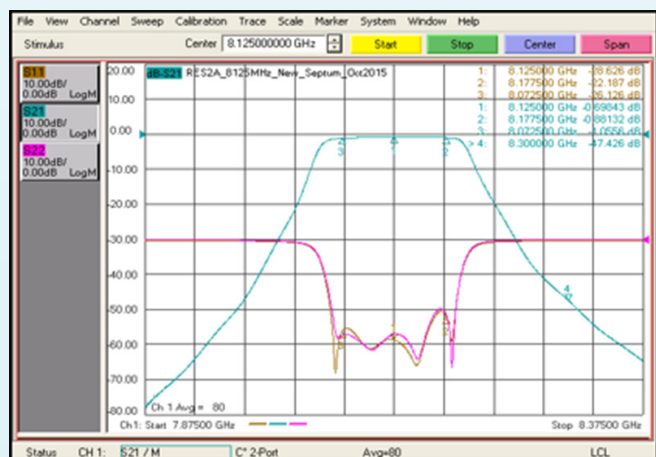

E-plane filter at X-band

## Specifications:

- Waveguide filter with high Q.
- Low insertion loss.
- Moderate bandwidths (1 to 7%).
- Easy to change centre frequency and bandwidth.
- Handles RF powers beyond 2kW.
- Simple in construction.
- Mass production suitability.

## Major Specifications:

- Centre frequency : 8.2 GHz.
- Bandwidth : 160 MHz.
- Insertion loss : 0.5 dB max.
- Return loss : 17 dB min.
- Group delay : 6 n sec max.
- Rejection : 90 dBc for lower frequency bands.
- Power handling : 200 W CW at vacuum conditions.
- RF interface : WR112 waveguide flange.
- Size : 50 x 35 x 200 mm<sup>3</sup>.
- Mass : 200 grams.

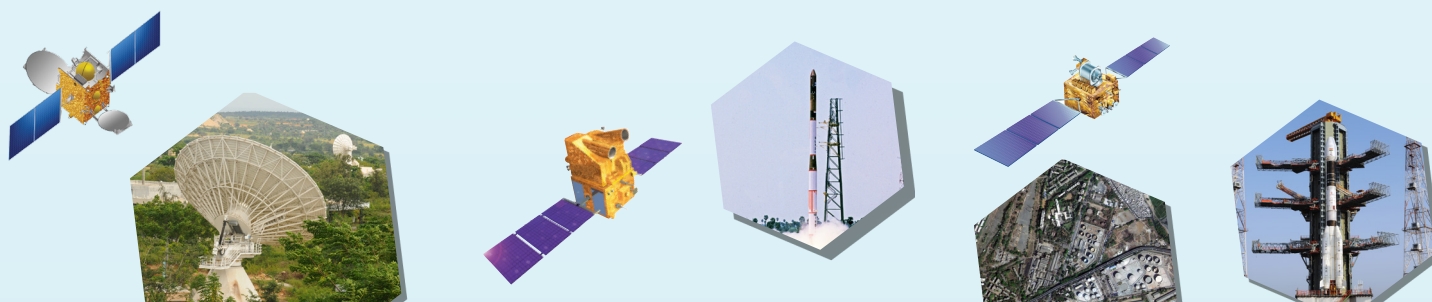

## Technology Transfer from ISRO

ISRO is willing to offer the knowhow of this technology to suitable entrepreneurs / industries in India. Capable manufacturing industries interested in acquiring this knowhow may write with details of their present activities, requirements and plans for implementation, infrastructure and technical expertise available with them, their own market assessment, if any, and plans for diversification to the address given below:

NewSpace India Limited (NSIL)

Email: [contact-nsil@isro.gov.in](mailto:contact-nsil@isro.gov.in)

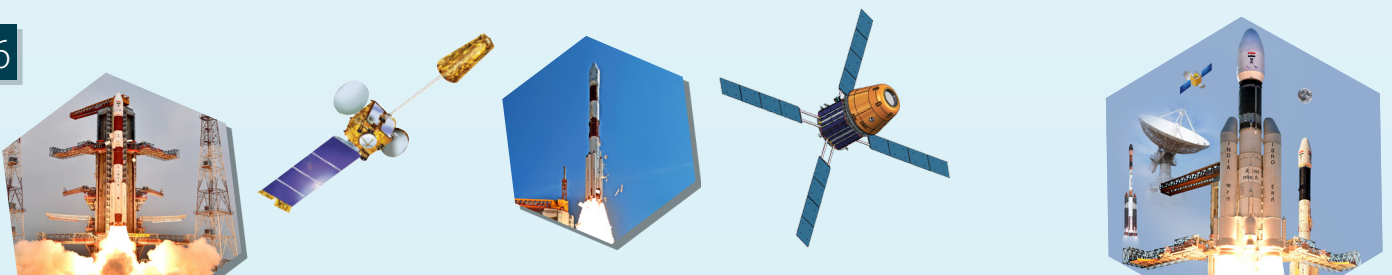

# Evanescent Mode Filters

U R Rao Satellite Centre (URSC) of Indian Space Research Organisation (ISRO) has developed Low loss microwave band pass filter designed for X-Band Data transmitter to allow required band of frequencies and rejecting all other frequencies.

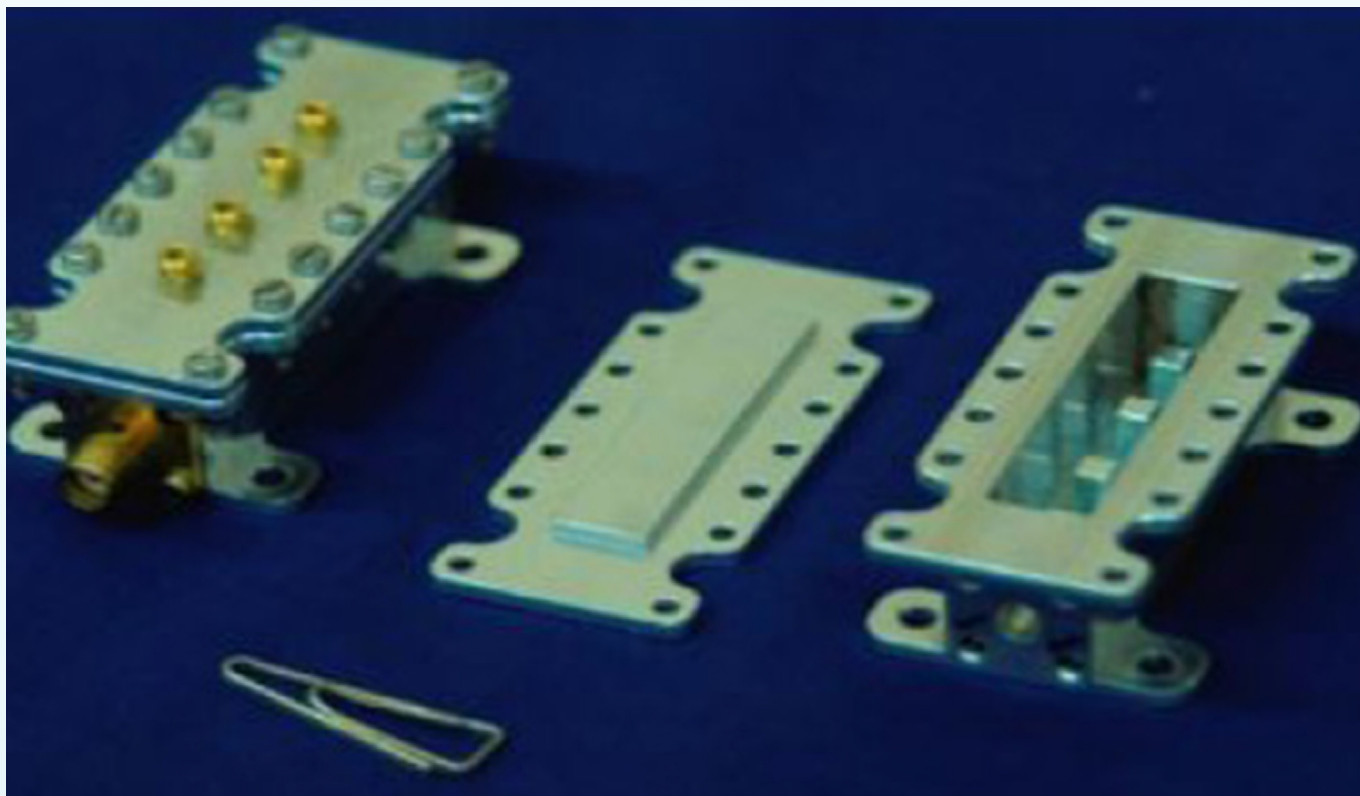

*E-plane filter at X-band*



*Measured Response of X Band Filter*

## Specifications:

- TEM mode operation in cavity.
- Narrow bandwidth.
- Symmetric skirt response.
- High rejection bandwidth.
- Coaxial interface.
- Compact and light weight.
- Mechanically robust.
- Mass production suitability.

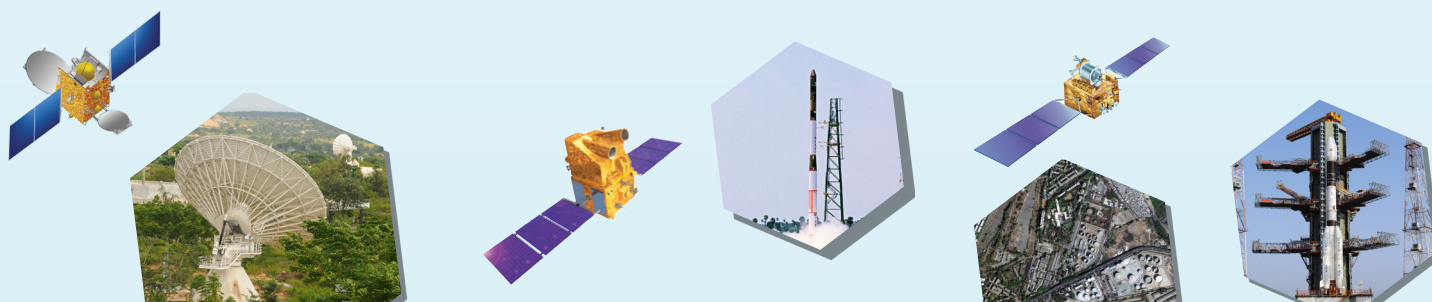

## Major Specifications:

Centre frequency	: 8.2 GHz
Bandwidth	: 360 MHz
Insertion loss	: 0.35 dB max
Return loss	: 17 dB min
Group delay	: 4 n sec max
Rejection	: 90 dBc up to 2f0
Power handling	: 20 W CW at vacuum conditions
RF interface	: SMA jack
Size	: 15 x 15 x 40 mm <sup>3</sup>
Mass	: 50 grams

## Technology Transfer from ISRO

ISRO is willing to offer the knowhow of this technology to suitable entrepreneurs / industries in India. Capable manufacturing industries interested in acquiring this knowhow may write with details of their present activities, requirements and plans for implementation, infrastructure and technical expertise available with them, their own market assessment, if any, and plans for diversification to the address given below:

NewSpace India Limited (NSIL)  
Email: [contact-nsil@isro.gov.in](mailto:contact-nsil@isro.gov.in)

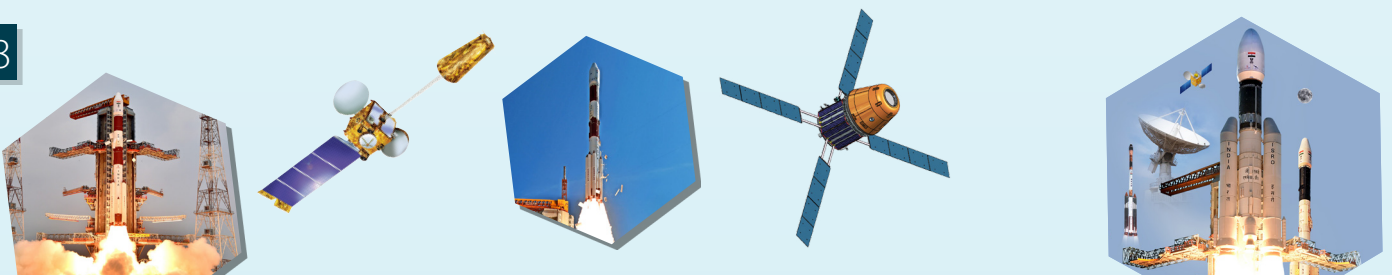

# Battery Charge Regulator (BCR)

U R Rao Satellite Centre (URSC) of Indian Space Research Organisation (ISRO) has developed Battery Charge Regulator (BCR) for battery charging and bus regulation. Battery charge regulator (BCR) is designed with Constant Current-Constant Voltage (CC-CV) and BUS priority loop to cater to LEO as well as GEO Satellites. The main feature of the BCR is that it has a mechanism to give priority to the load requirements in preference to battery charging whenever there is a power generation deficit in the solar array.

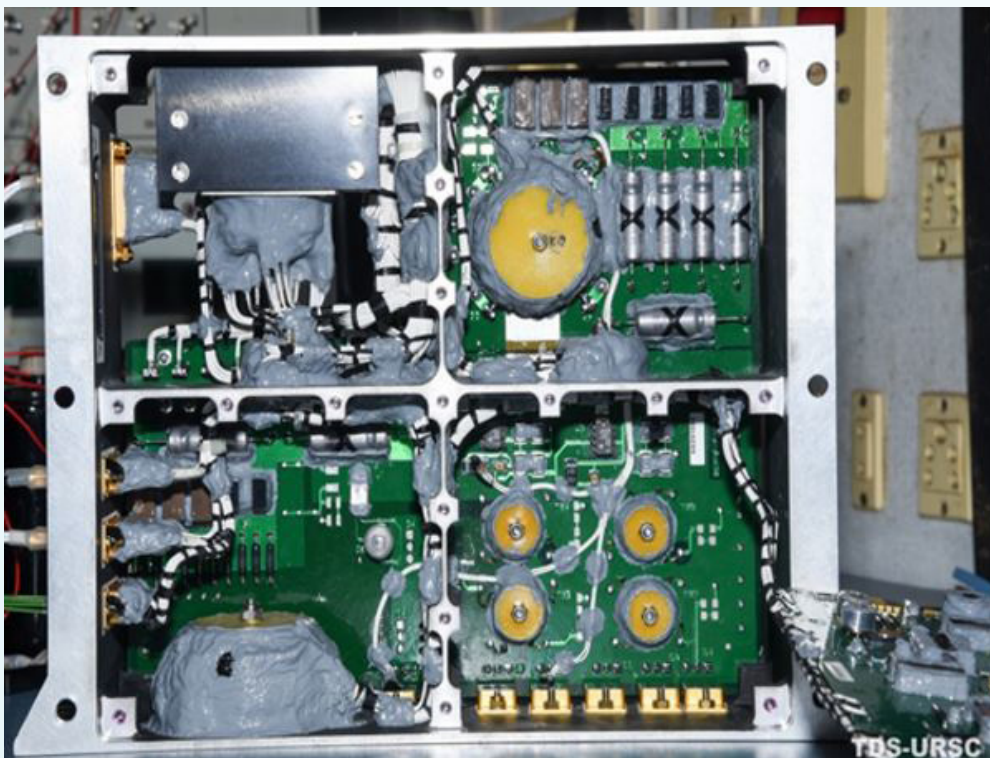

*Battery Charge Regulator (BCR)*

## Specifications:

- TEM mode operation in cavity.
- Narrow bandwidth.
- Symmetric skirt response.
- High rejection bandwidth.
- Coaxial interface.
- Compact and light weight.
- Mechanically robust.
- Mass production suitability.

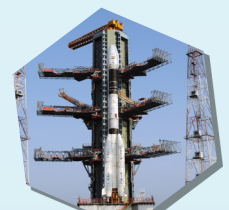
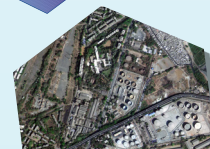
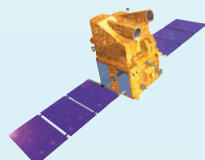
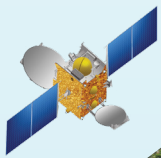

## Major Specifications:

Dimensions (L × W × H)	:	286×70×212 [mm]
Mass	:	2500 gram
BUS Voltage	:	71 Volts
Power Dissipation @ BCR Pout =700W	:	< 30 Watt
Current TM	:	0-5V
Output Current (Selectable)	:	0 -> 10A (00H -> FFH)
Output Voltage (Selectable)	:	0 -> 67.2V (00H-> FFH)
Output Power Capability	:	800Watt (Max)
Efficiency @ BCR Pout =700W	:	>95%
Output Current	:	10A
Over Current Protection	:	> 12A

## Technology Transfer from ISRO

ISRO is willing to offer the knowhow of this technology to suitable entrepreneurs / industries in India. Capable manufacturing industries interested in acquiring this knowhow may write with details of their present activities, requirements and plans for implementation, infrastructure and technical expertise available with them, their own market assessment, if any, and plans for diversification to the address given below:

NewSpace India Limited (NSIL)

Email: [contact-nsil@isro.gov.in](mailto:contact-nsil@isro.gov.in)

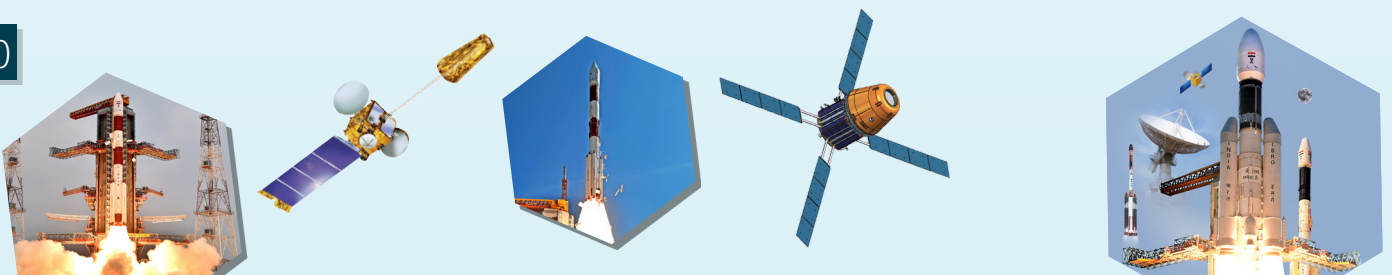

# Battery Discharge Regulator

U R Rao Satellite Centre (URSC) of Indian Space Research Organisation (ISRO) has developed a Battery Discharge Regulator to maintain the bus regulation during eclipse and peak power requirement periods to avoid the off-optimal operation of the solar array and consequent over sizing of battery. BDR is a Boost Regulator, which regulates the bus voltage in-spite of the variations in the battery voltage. This results in 3 to 4% improvement in the overall efficiency of the user DC-DC and TWTA converters. BDR is modular in nature and can be scaled according to the load requirement.

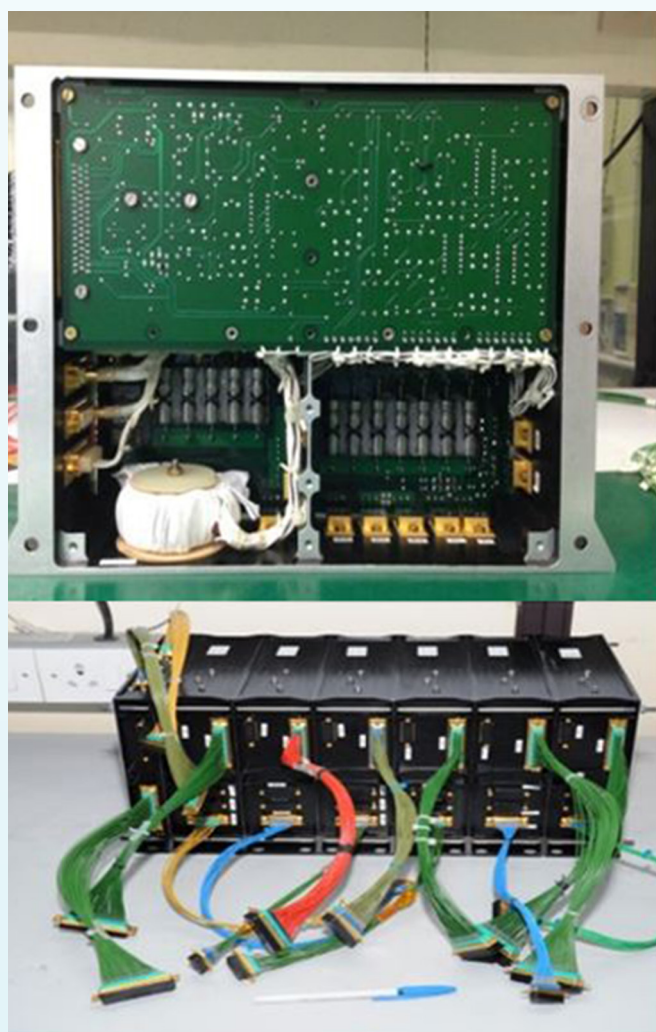

*Battery Discharge Regulator*

## Specifications:

- Average Current Mode programming for load current sharing.
- Alternate path for fuse blow current and turn on inrush currents.
- Current transformer sense for implementing OCP.
- MVL based inclusion/exclusion.
- Protection Circuits:
  - Pulse by pulse type output over current limit protection.
  - Over voltage limit protection for Output over Voltage.

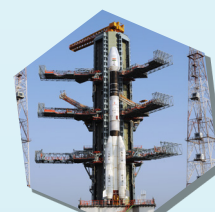
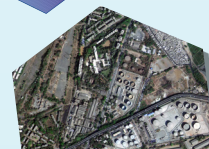
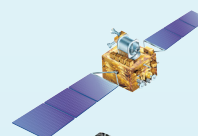
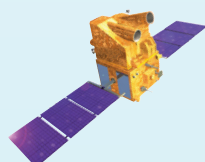
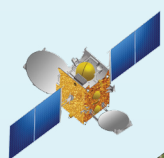

## Major Specifications:

Input Voltage (V)	:	45 to 67V
Output Voltage (V)	:	69.5±0.5
Output Power (W)	:	1000W
Topology	:	Non Isolated Boost
Efficiency (%)	:	>94%
OVP Limit (V)	:	77V (110%)
Current Limit (%)	:	120 % of Full (100%) Load Current Telemetry
	• Analog	: Output Voltage, Output Current
	• Digital	: Ovp Relay & On/Off Relay Status
Dimensions (L*W*H)	:	86*70*212(mm3)
Package Mass	:	2.5kg

## Technology Transfer from ISRO

ISRO is willing to offer the knowhow of this technology to suitable entrepreneurs / industries in India. Capable manufacturing industries interested in acquiring this knowhow may write with details of their present activities, requirements and plans for implementation, infrastructure and technical expertise available with them, their own market assessment, if any, and plans for diversification to the address given below:

NewSpace India Limited (NSIL)

Email: [contact-nsil@isro.gov.in](mailto:contact-nsil@isro.gov.in)

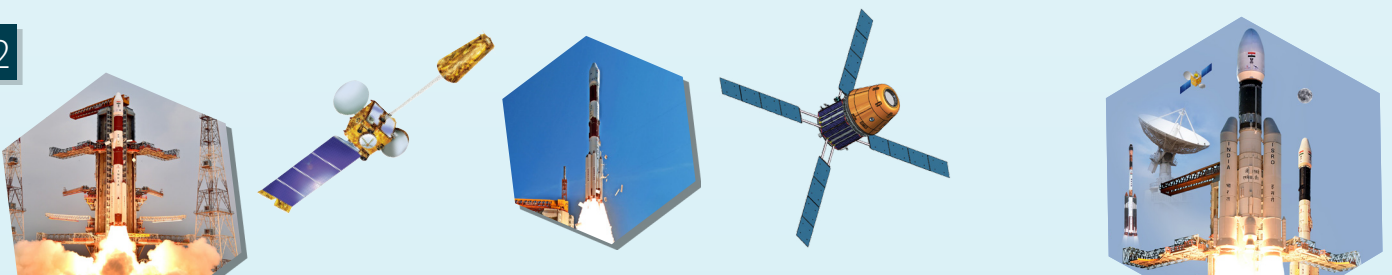



# Eddy Current Damper

U R Rao Satellite Centre (URSC) of Indian Space Research Organisation (ISRO) has developed Eddy current Damper, a deployment rate control device. It is passive in nature and makes use of the resistive eddy currents developed when a nonmagnetic conductive disc rotates in a magnetic field. The damper employs a gear train to amplify the resistive torque generated. The damper is used to control the deployment rate of the solar array and bring down the latch up shock on the panels. The resistive torque developed is proportional to the rate of rotation of the disc and hence rate of deployment of the panels is self-regulating.



Battery Discharge Regulator

## Specifications:

- Very high damping rate.
- Wide temperature range.
- Non contact type and good reliability.
- Good temperature stability.

## Major Specifications

Salient Damper Specifications	
Damping Rate	0.9, 2.2, 2.8 kgf-cm/rad/s
Mass	0.5 kg
Magnet Type	Samarium Cobalt
Gear Type	Spur Gear / Planetary

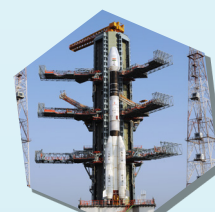
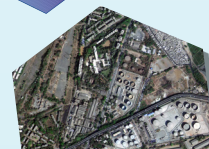
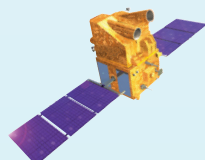
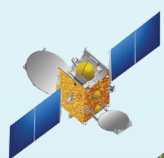

## Technology Transfer from ISRO

ISRO is willing to offer the knowhow of this technology to suitable entrepreneurs / industries in India. Capable manufacturing industries interested in acquiring this knowhow may write with details of their present activities, requirements and plans for implementation, infrastructure and technical expertise available with them, their own market assessment, if any, and plans for diversification to the address given below:

NewSpace India Limited (NSIL)

Email: [contact-nsil@isro.gov.in](mailto:contact-nsil@isro.gov.in)

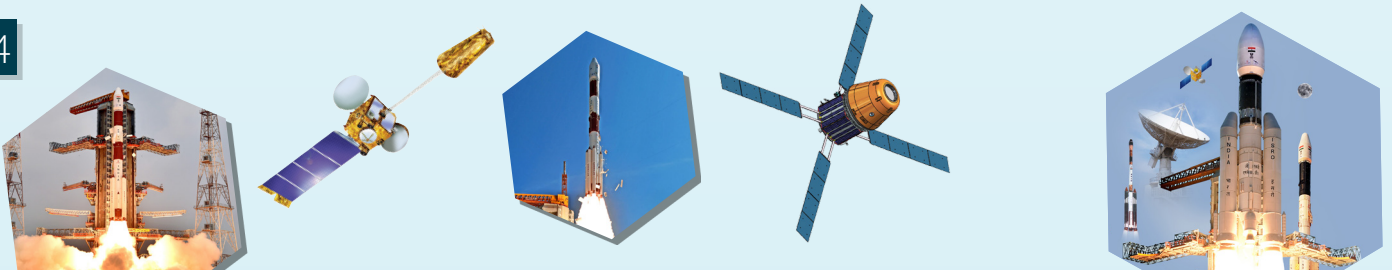

# Foil Heaters Using Pyralux<sup>®</sup> Adhesive

U R Rao Satellite Centre (URSC) of Indian Space Research Organisation (ISRO) has developed Kapton<sup>®</sup> Foil heaters using Pyralux adhesive for power rating of 2.5 Watts per square inch. Using the technology, heaters of different sizes and resistances are fabricated, tested and implemented on the satellite components for temperature rise so that components are maintained above its lower operating limit.

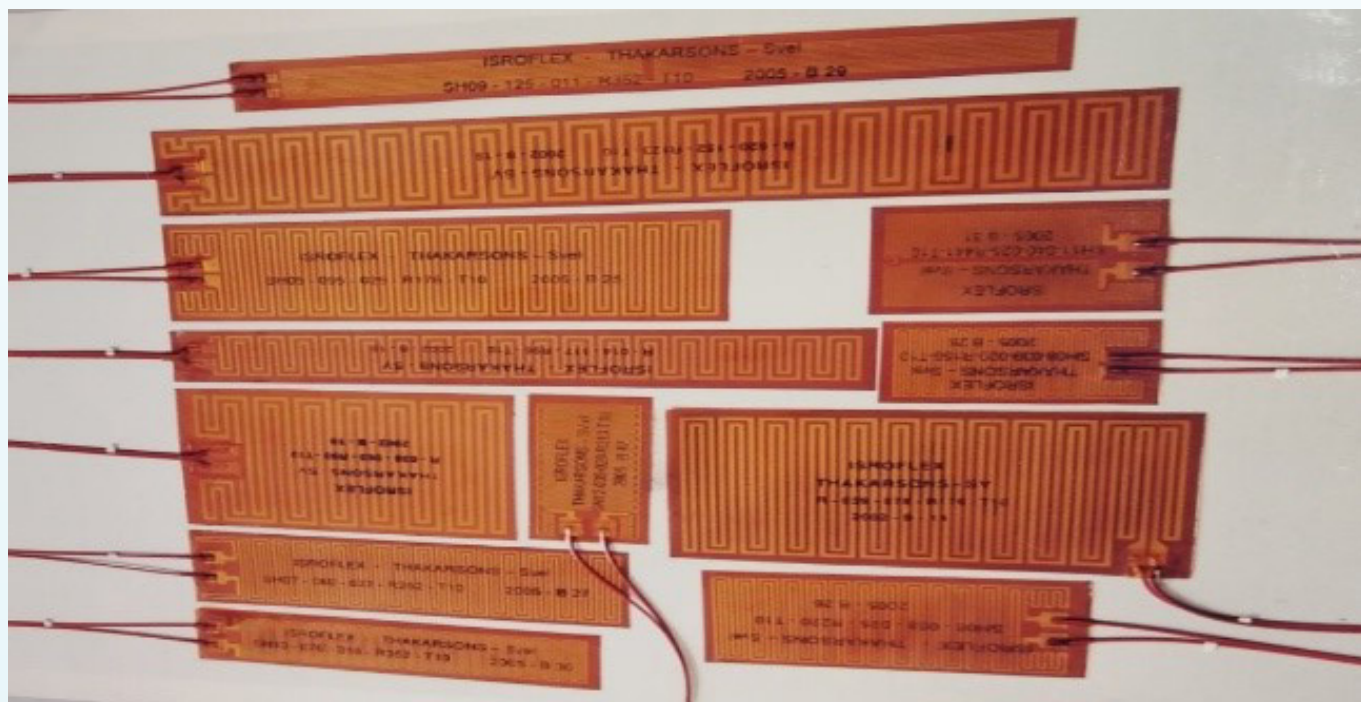

*Foil heaters*

## Specifications:

- The heaters are thin flexible heating elements laminated between insulating layers of Kapton<sup>®</sup>
- Heater sizes and Resistances can be varied as per the requirement.
- Heaters are qualified to NASA-GSFC-S-311-79 standard.
- Heaters of insulation resistance more than Gohm.
- Dielectric strength is more than 500 Vrms.

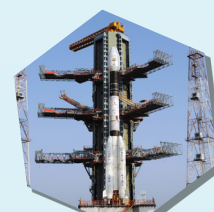
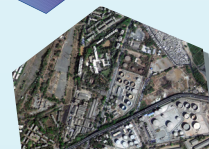
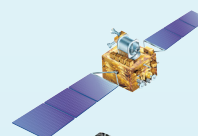
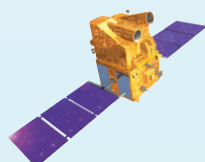
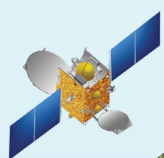

## Major Specifications:

Power Rating	: 2.5 Watts per sq.in in still air
Heater leads	: 26AWG, Kapton insulated and 0.5 m long
Resistance tolerance	: $\pm 10\%$
Operating temperature range	: -65 OC to +150 OC
Mounting Method	: Using transfer adhesive

## Technology Transfer from ISRO

ISRO is willing to offer the knowhow of this technology to suitable entrepreneurs / industries in India. Capable manufacturing industries interested in acquiring this knowhow may write with details of their present activities, requirements and plans for implementation, infrastructure and technical expertise available with them, their own market assessment, if any, and plans for diversification to the address given below:

NewSpace India Limited (NSIL)

Email: [contact-nsil@isro.gov.in](mailto:contact-nsil@isro.gov.in)

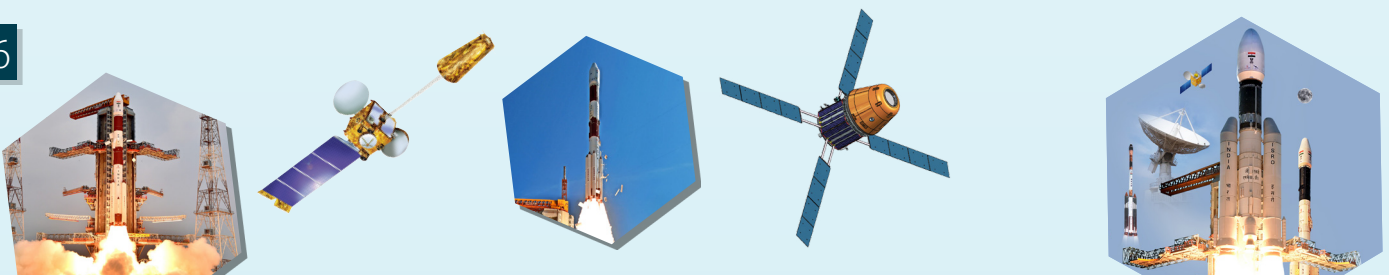

# Fine line PCB Technology for Fine-pitch surface Mount Devices

U R Rao Satellite Centre (URSC) of Indian Space Research Organisation (ISRO) has develop and qualify the technology for PCBs with fine conductor features of 5 mil trace width and 4 mil spacing to cater for various fine pitch surface mount devices in the Solid State Recorder (SSR) packages of high resolution imaging LEO Satellites.

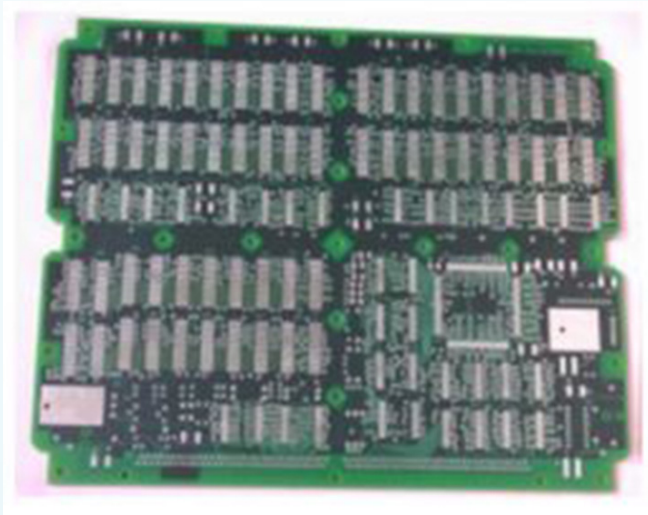

*Fine Line SSR Multiplayer PCB Replaced 6 Normal MLBs*

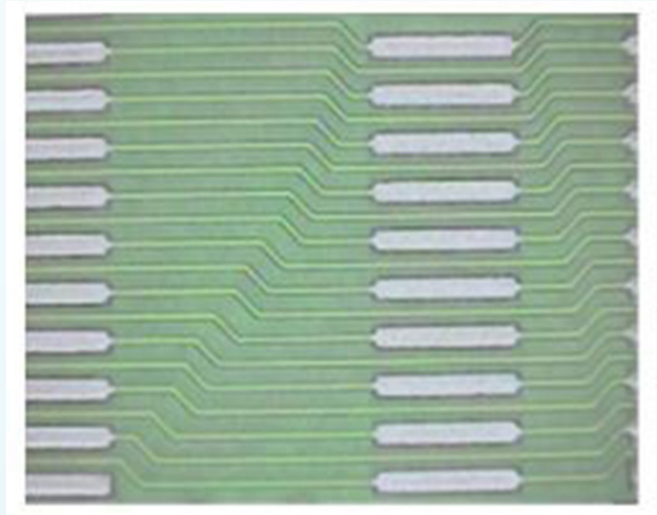

*Fine Lines Replaced with Liquid Photoimageable Resist*

## Salient Features & Major Specifications.

Laminate material	: High-Tg FR4
Total PCB Thickness	: 2.25 mm $\pm$ 0.15 mm
Minimum through hole size	: 0.40 mm (16 mils) finished
Minimum drilled hole size	: 0.50 mm diameter
Standard through hole size	: 0.80 mm (32 mils) finished
Minimum pad diameter	: 1.0 mm (40 mils) by design
Standard hole pad diameter	: 1.5 mm (60 mils) by design
Minimum Trace width	: 0.125 mm (5 mils) by design
Minimum spacing	: 0.100 mm (4 mils) by design
Minimum Dielectric separation	: 100 $\mu$ m (4 mils)

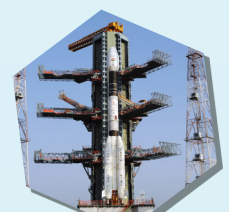
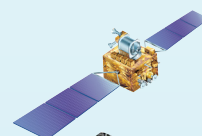
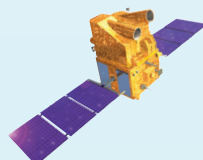
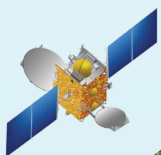

Outer layer basic copper	: ½ oz (17.5 microns)
Outer layer Copper thickness	: 52.5 (± 10) µm (External) finished
Inner layers Copper thickness	: 30 (± 05) µm, Internal
Multilayer Construction	: Laminate type construction
Fabrication Technique	: Subtractive type, Electroless Copper, SMOBC
Solder mask material	: Electra EMP110, Carapace
Surface finish	: Eutectic Solder (Sn-63 / Pb-37)

## Technology Transfer from ISRO

ISRO is willing to offer the knowhow of this technology to suitable entrepreneurs / industries in India. Capable manufacturing industries interested in acquiring this knowhow may write with details of their present activities, requirements and plans for implementation, infrastructure and technical expertise available with them, their own market assessment, if any, and plans for diversification to the address given below:

NewSpace India Limited (NSIL)  
Email: [contact-nsil@isro.gov.in](mailto:contact-nsil@isro.gov.in)

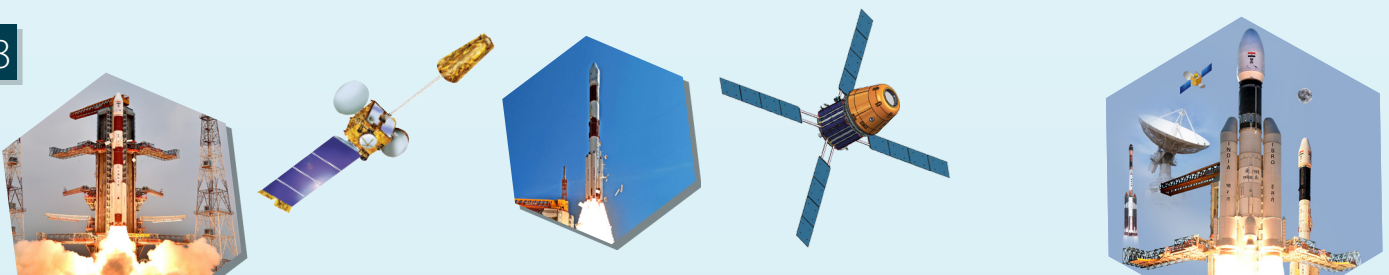

# Rigid-flex multilayer PCB Technology

UR Rao Satellite Centre (URSC) of Indian Space Research Organisation (ISRO) has Rigid-flex multilayer PCB Technology for high reliability 3D packaging applications in space electronics. The rigid-flex multilayer PCB technology provides several benefits with minimized connectors, harness, and motherboard assemblies, eliminates human errors, and also results in reduced weight and volume for interconnecting different functional electronics through flexible structures in 3D Packaging.

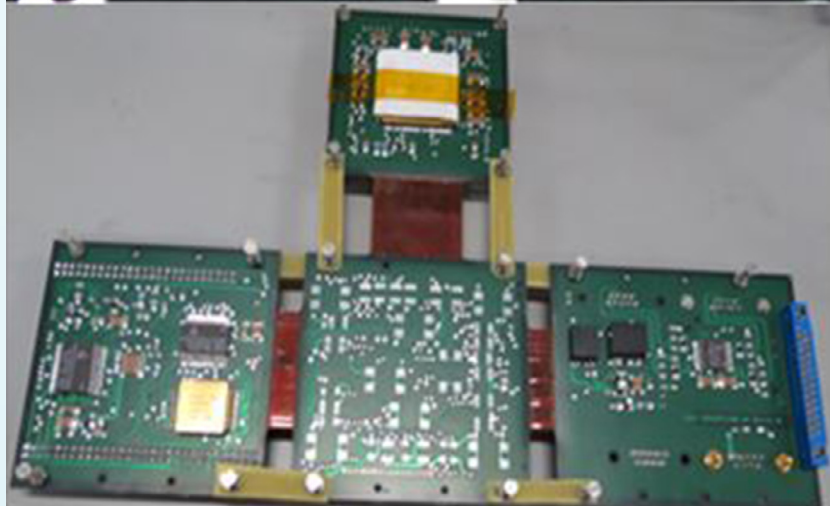
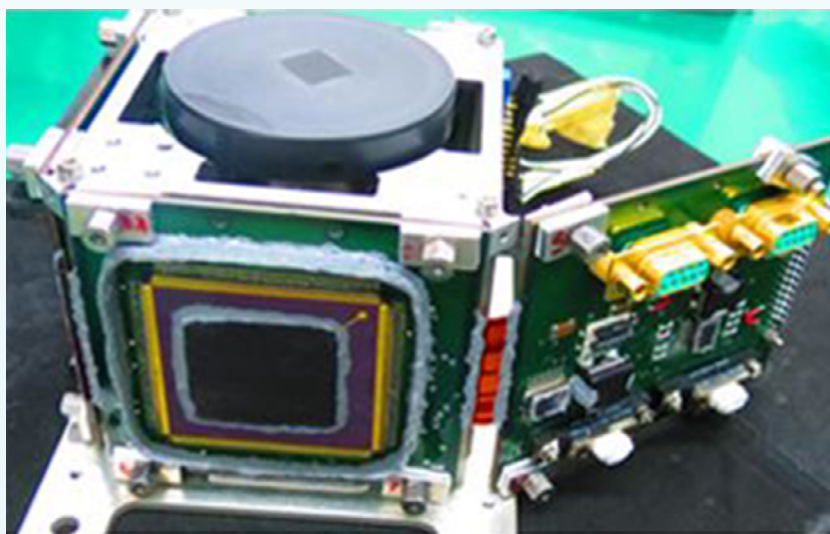

*Rigid-Flex Multiplayer PCB*

## Specifications:

- 3D packaging feasibility.
- Reduced Weight & Volume with minimized Harness & Connectors.

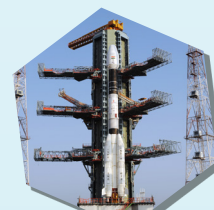
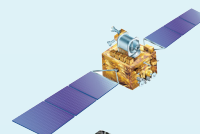
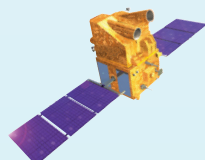
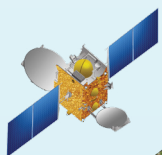

## Major Specifications

Parameter	Specifications
Type of PCB	Rigid-flex combination with one (or) two layers of flex
No. of Layers	3 layers to 14 layers total, as per layer stack diagram
Total PCB Thickness	Minimum 1.6mm to 2.3 mm maximum (Rigid portion) 0.2 mm to 0.4 mm (Flexible portion)
Material for Rigid Laminate	Glass-polyimide, Tg > 240°C, complying to IPC 4101/41 specifications
Material for Flexible Core	All polyimide, adhesive-less, Tg > 210°C, complying to IPC 4204/11 specifications
Material for Flexible Coverlay	Kapton film (25 to 50 microns thick) with adhesive on one side, complying to IPC 4203/1 specifications
Material for Bonding flex and Rigid Layers	Low-flow glass-polyimide, complying to IPC 4101/41 specifications
Inner Layer Copper Thickness	35 microns for double side flex 35 microns (or 70 microns) for single side flex 35 microns for all rigid layers
External Layer Copper Thickness	Total 52 microns to 70 microns, including 35 microns plated copper, as specified in layer stack diagram
Etchback	Positive etchback of 5 to 15 µm, complete desmear is also acceptable, negative etchback is not allowed
Multilayer Construction	Laminate type construction
Fabrication Technique	Subtractive process, Electroless Copper, SMOBC
Solder Mask Material	Electra EMP110 (or) Taiyo PSR-4000BN
Surface Finish	Solder or Electroless Nickel Immersion Gold (ENIG)
Solder Specifications	Tin - 63% / Lead - 37%
ENIG Specifications	0.05 microns gold with 3 to 6 µm Nickel undercoat
Bare board test (BBT)	Rigid-flex PCB shall pass electrical test for continuity and isolation

## Technology Transfer from ISRO

ISRO is willing to offer the knowhow of this technology to suitable entrepreneurs / industries in India. Capable manufacturing industries interested in acquiring this knowhow may write with details of their present activities, requirements and plans for implementation, infrastructure and technical expertise available with them, their own market assessment, if any, and plans for diversification to the address given below:

NewSpace India Limited (NSIL)

Email: [contact-nsil@isro.gov.in](mailto:contact-nsil@isro.gov.in)

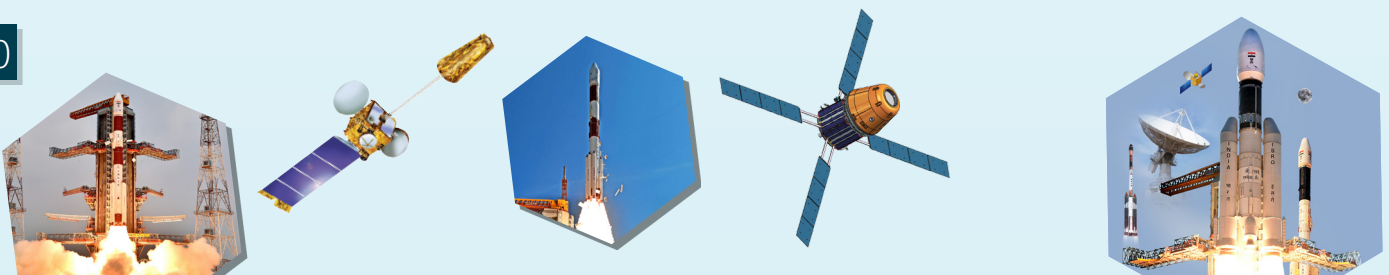



# HMC DC-DC Converters (30W)

U R Rao Satellite Centre (URSC) of Indian Space Research Organisation (ISRO) has developed 30 W HMC DC-DC Converters to meet Electrical performance with High Reliability requirements for Space Application with minimum size and weight. HMC DC-DC Converters developed for Space Application adopting Innovative Thick Film Process technology developed and qualified for Space application.



30W HMC DC - DC Converter

## Specifications:

- Meets Electrical performance with High Reliability requirements for Space Application.
- Minimum size and weight.

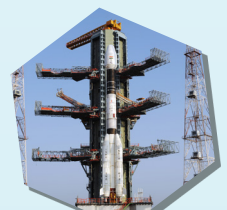
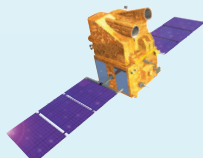
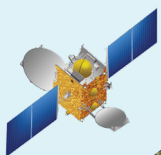

## Major Specifications:

The main features of the 30W HMC DC-DC Converter are as follows:

- Converter design meets high reliability requirements and provides output voltages of +5V, +15V and -15V.
- Components (in die form) used are compliant to MIL-38534 QML-V or Class-K
- Hybrid design and fabrication processes comply to ISRO-PAS-206 guidelines.
- Innovative thick film process technology with special subassemblies adopted for realisation of the power hybrid which is housed in custom designed package of Molybdenum base and Kovar ring.
- The Converter performance suits typical space electronic systems up to 30W, covering requirements of EMI, regulation, thermal dissipation and standard protection features.

The main specifications are as follows:

Input voltage range : 26-42V

Triple outputs ( $\pm 15V$  and +5V) delivering up to 30W

Built-in EMI filter capable of meeting ISRO Standards (based on MIL-461C)

Converter shutdown feature

Efficiency : 75%

Switching frequency : 250 KHz

Short circuit, over load and under voltage lockout protections

Telemetry monitoring feature

Size : 3.5"x3.5"x0.65"

Weight : 245 gms

## Technology Transfer from ISRO

ISRO is willing to offer the knowhow of this technology to suitable entrepreneurs / industries in India. Capable manufacturing industries interested in acquiring this knowhow may write with details of their present activities, requirements and plans for implementation, infrastructure and technical expertise available with them, their own market assessment, if any, and plans for diversification to the address given below:

NewSpace India Limited (NSIL)

Email: [contact-nsil@isro.gov.in](mailto:contact-nsil@isro.gov.in)

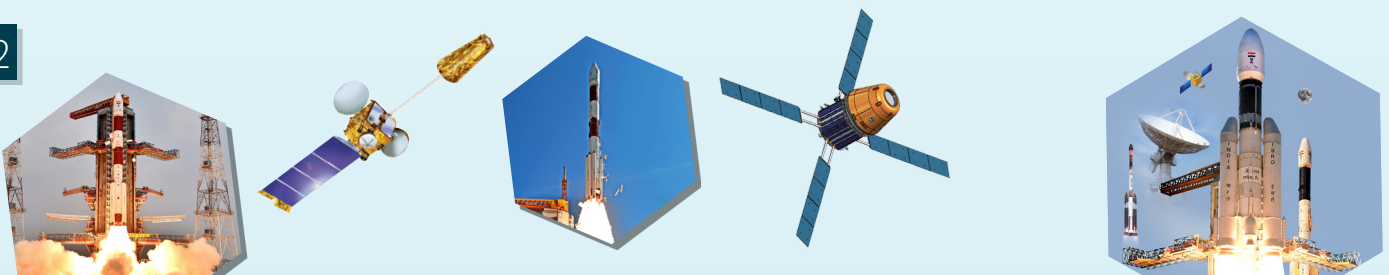

# Advanced High Data Rate Modulator

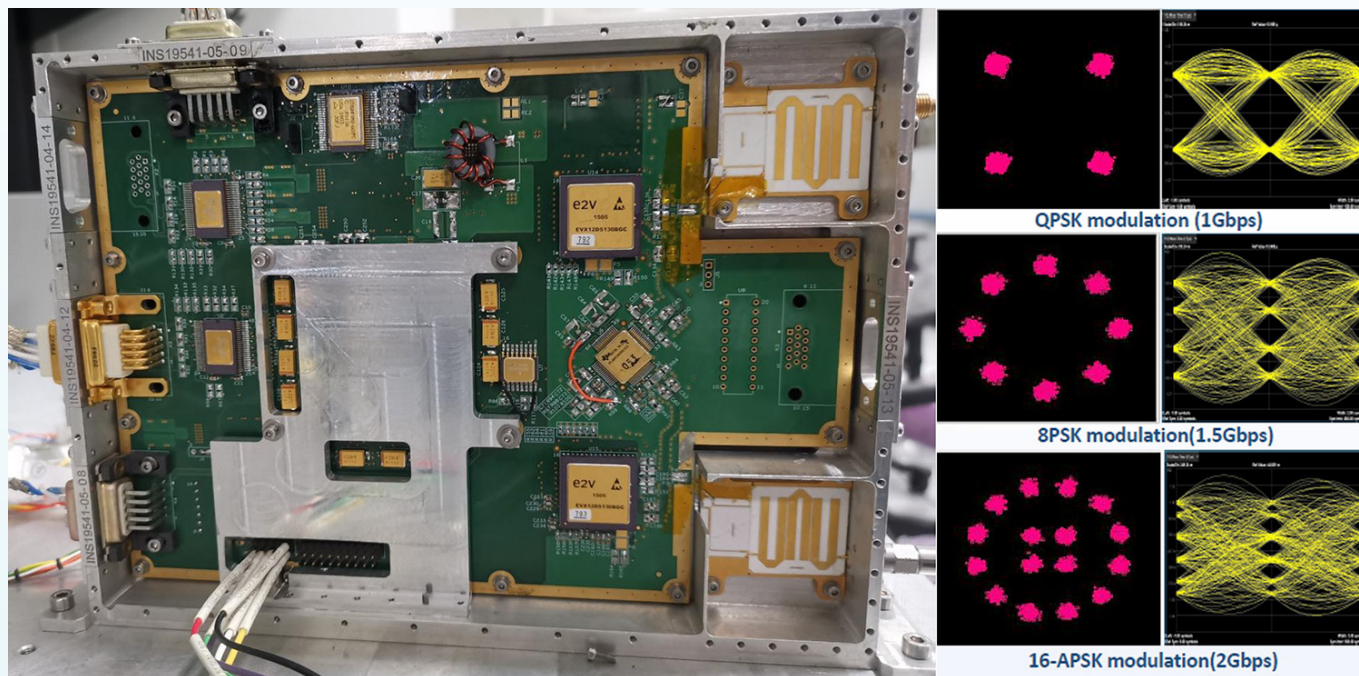

Advance High Data Rate Modulators

## Salient Features :

- Complete Digital implementation for GEO-optical payload
- Telecommand configurable modulation schemes
- 16-APSK modulation: 2Gbps/ 675MHz BW
- 8-PSK modulation: 1.5 Gbps/ 675MHz BW
- QPSK modulation: 1 Gbps/ 675MHz BW
- Root raised cosine filter with  $\alpha=0.35$
- Two 1.575Gbps SERDES interface for data acquisition, Virtex-5 FPGA, Wide band clock synthesizer, High speed DACs
- DAC and RF Gain flatness response compensation in FPGA
- Two DAC synchronization for external IQ modulator
- Temperature cycling completed in  $-10^{\circ}\text{C}$  to  $60^{\circ}\text{C}$

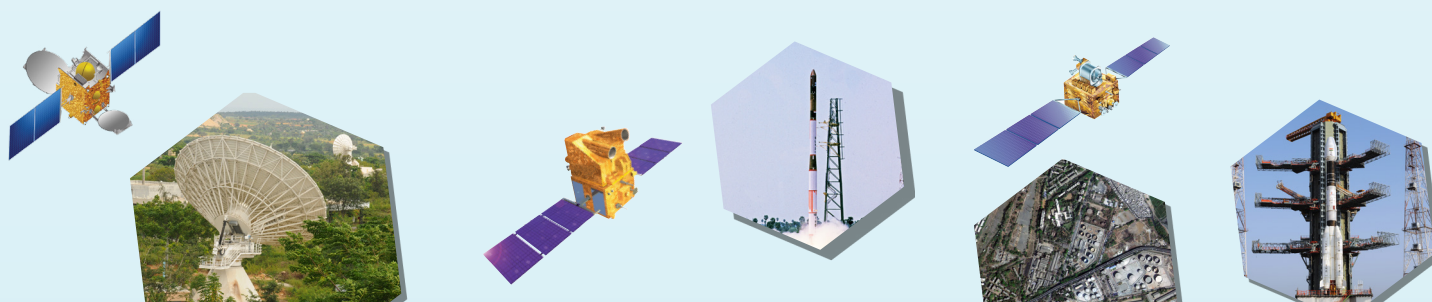

## Technology Transfer from ISRO

ISRO is willing to offer the knowhow of this technology to suitable entrepreneurs / industries in India. Capable manufacturing industries interested in acquiring this knowhow may write with details of their present activities, requirements and plans for implementation, infrastructure and technical expertise available with them, their own market assessment, if any, and plans for diversification to the address given below:

NewSpace India Limited (NSIL)

Email: [contact-nsil@isro.gov.in](mailto:contact-nsil@isro.gov.in)

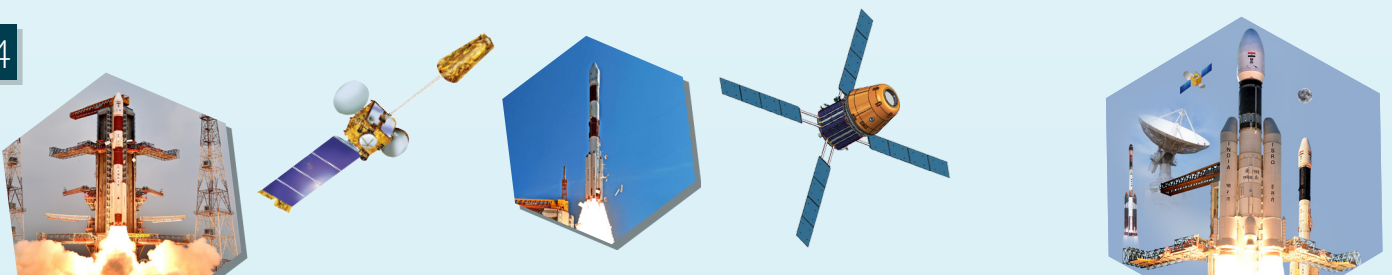

# Miniaturized methane sensor based on GRIN lens

Space Applications Centre (SAC) has developed a miniaturized methane sensor using GRIN lens and small etalons is developed which is well capable to measure Earth methane and to fly on airborne platform to map Earth's methane. This is a first of its kind of sensor based on GRIN lens. The lens is 1.8 mm clear aperture and 4.54 mm of length. The collecting lens was chosen such that the spot size is lesser than the clear aperture of the GRIN lens so that the entire energy can be coupled with the the GRIN lens. The sensor can be flown from spaceborne platform (for Earth's Methane observation) with proper qualification and modification in electronics and including necessary interfaces.

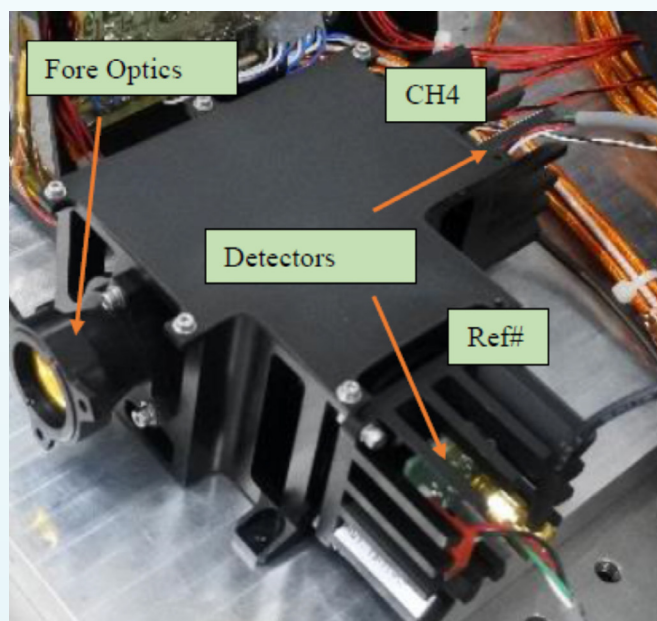

## Applications area :

The potential application areas are Industries, agricultural department/universities, dairy research, paddy cultivation, Livestock, Environmental science departments. The payload is primarily designed for airborne platform. The performance achieved is suitable to use it for airborne measurement. The weight and power of the instrument is also suitable for nanosatellite.

## Salient Features:

Parameters	Values
Detector Type	InGaAs, Single Pixel detector, One for each Channel
Detector size	1 mm
Fore optics diameter	24.5 mm
Focal length	25.4 mm
IFOV	39.3 mrad
Responsivity	1 A/W
Targeted Methane concentration measurement and SD	1800 ppb of Earth's atmospheric column with SD ~100 ppb.

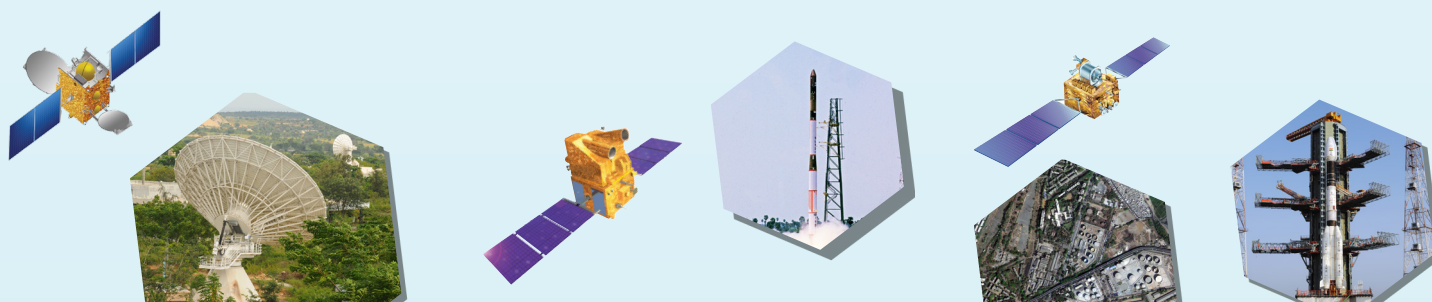

## GRIN Lens replaces collimating optics

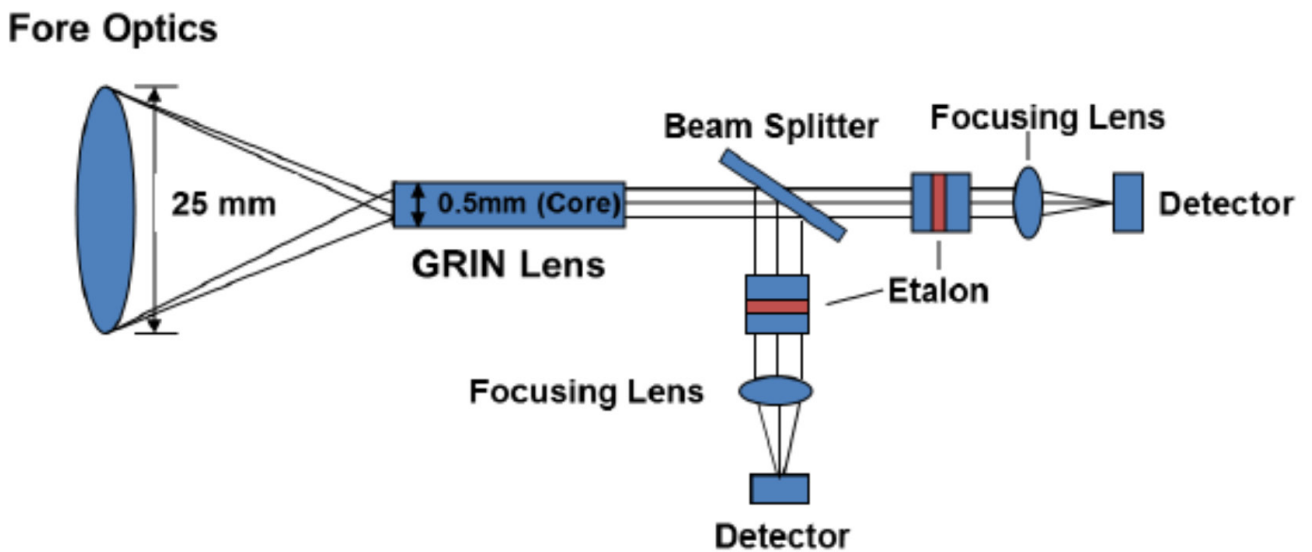

### Technology Transfer from ISRO

ISRO is willing to offer the knowhow of this technology to suitable entrepreneurs / industries in India. Capable manufacturing industries interested in acquiring this knowhow may write with details of their present activities, requirements and plans for implementation, infrastructure and technical expertise available with them, their own market assessment, if any, and plans for diversification to the address given below:

NewSpace India Limited (NSIL)

Email: [contact-nsil@isro.gov.in](mailto:contact-nsil@isro.gov.in)

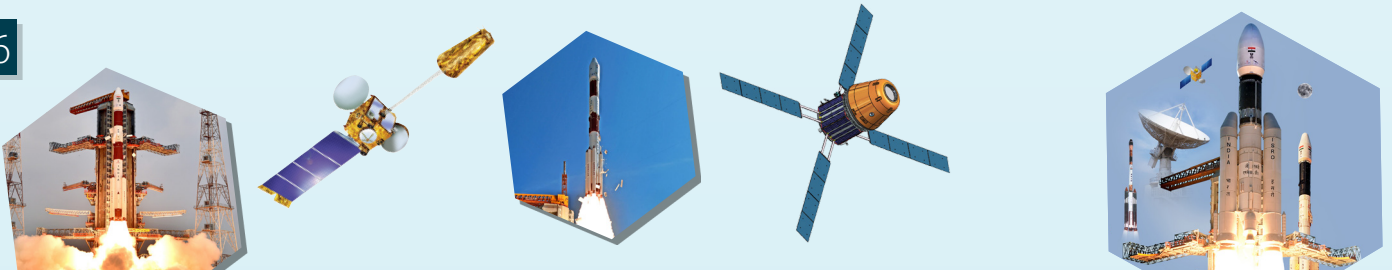

# Active 3D Imaging Lidar Camera

Space Applications Centre (SAC) has developed an Active 3D imaging Lidar camera that works on Time-of-Flight (ToF) principle. The camera measures the depth of scene points using flash LIDAR (Light Imaging Detection and Ranging) technology. The depth information is determined by correlating the reflected light signal from the scene with the transmitted reference signal. The three-dimensional data obtained from ToF sensor can be used for many control and navigation applications. This technology is useful to generate intensity and depth profile of targets irrespective of ambient lighting condition.

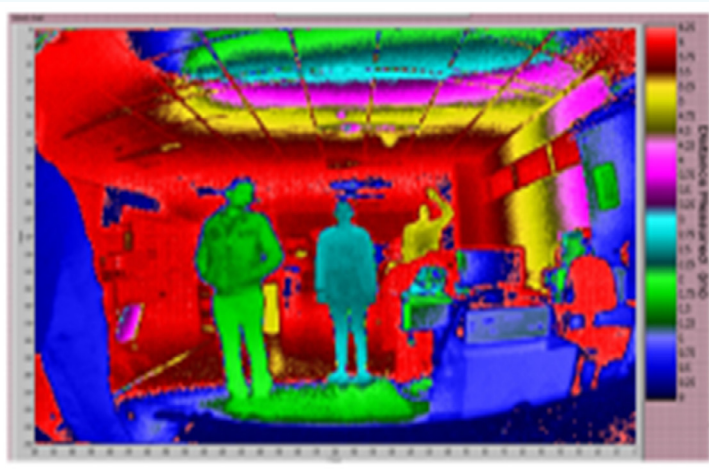

3D Point Cloud Depth Map Using this Camera

## Applications areas of the Technology :

This technology can also be primarily useful for following other application areas:

- People Detection and counting in heavily crowded place
- Mobile postal parcel size measurement for large scale logistics
- Machine Safety using depth measurement
- Helicopter Near Terrain flight assistance for assisted landing
- Hazard detection for Car Collision avoidance system
- Hazard detection for Pedestrian detection and braking system
- Body size measurement predicting the waist, hip size and further prediction of lifestyle issues.
- Man, Machine Interface like gesture recognition devices in mobile phone, TV, Xbox gaming sets, etc.
- 3D distance measurements, volumetric mapping of objects
- Space Docking between 2 docking satellites
- Interplanetary Soft Landing: Hazard Detection

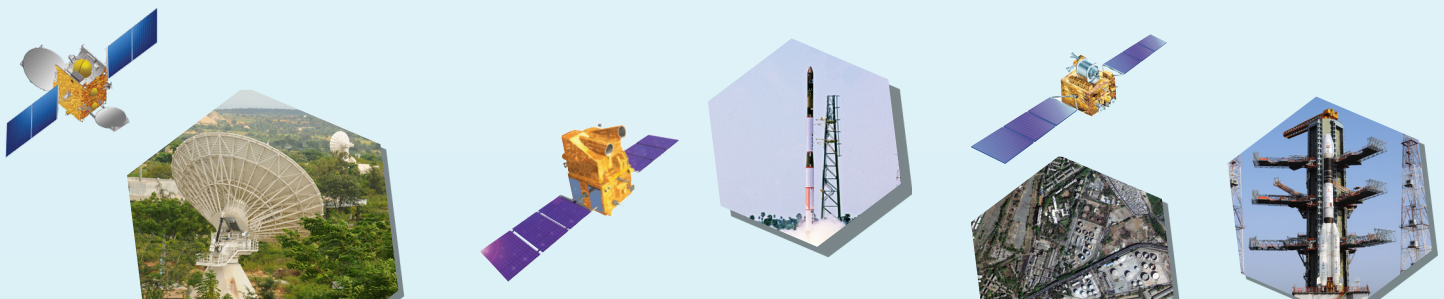

**Salient Features:**

SI No.	Parameters	Specifications
1	Lidar Technology	Phase detection
2	Wavelength	860 nm
3	Depth Range	up to 12 meters
4	Depth Accuracy	< 10 cm for range up to 5 m
5	Update Rate (Camera)	5 Fps
6	FOV	90°x60°
7	3D Points Per frame	76800 Points per frame
8	Dimension	370 x 275 x 246 mm
9	Mass	8 Kg
10	Power	42 W ( Average)

**Camera Features:**

- Option to view the Intensity image or the color coded depth point cloud
- Unique ambient light suppression, the camera can be used under full sunlight condition.
- Absolute accuracy in the sub-centimeter range with appropriate setup and calibration
- Dual phase mode for Motion blur reduction
- 2\*2 Binning option for range enhancement.
- Dual Integration time mode (High Dynamic Range, HDR mode)
- Sensor Measurement rate up to 20 TOF frames per second and camera about 5 TOF frames per second.
- Region of interest setting to maximize the Frame rate in KHz.
- Programmable exposure time to adjust the SNR and hence the depth accuracy. Real time display to fine tune the exposure to achieve the maximum depth accuracy while avoiding pixel saturation.

**Technology Transfer from ISRO**

ISRO is willing to offer the knowhow of this technology to suitable entrepreneurs / industries in India. Capable manufacturing industries interested in acquiring this knowhow may write with details of their present activities, requirements and plans for implementation, infrastructure and technical expertise available with them, their own market assessment, if any, and plans for diversification to the address given below:

NewSpace India Limited (NSIL)  
Email: [contact-nsil@isro.gov.in](mailto:contact-nsil@isro.gov.in)

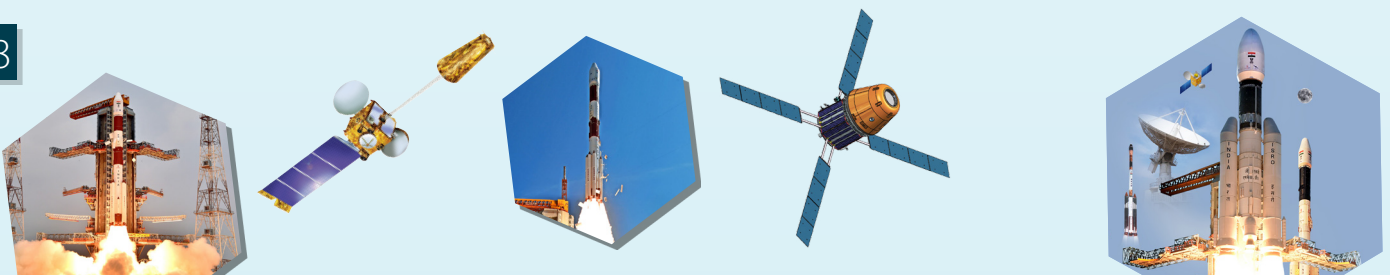



# Highly Accelerated Thermal Shock (HATS) System for assessment of PCB via reliability

Space Applications Centre (SAC) has developed indigenous Highly Accelerated Thermal Shock (HATS) System for assessment of PCB via reliability. The system is realized by assembly and integration of thermal conditioning system, which is used to give thermal shock and preconditioning simulation, and specially designed instrumentation, which acquires and processes the 4-wire resistance measurement data in real time. The data acquisition and monitoring application is developed in-house. Another offline data processing application is also developed to process the data and find the peak resistance variation of all nets of each PCB coupon (total 32 nets).

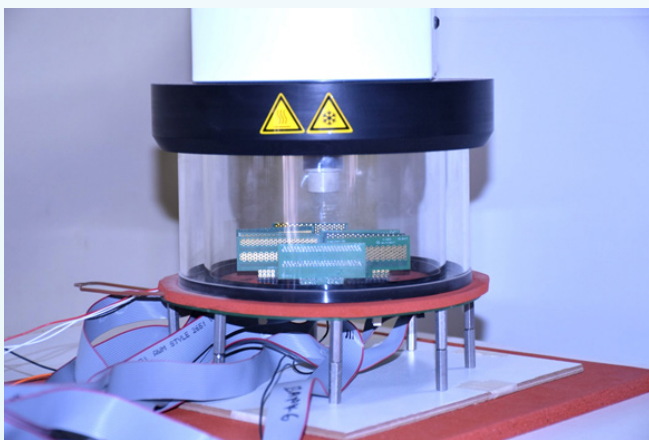

HATS Test Setup

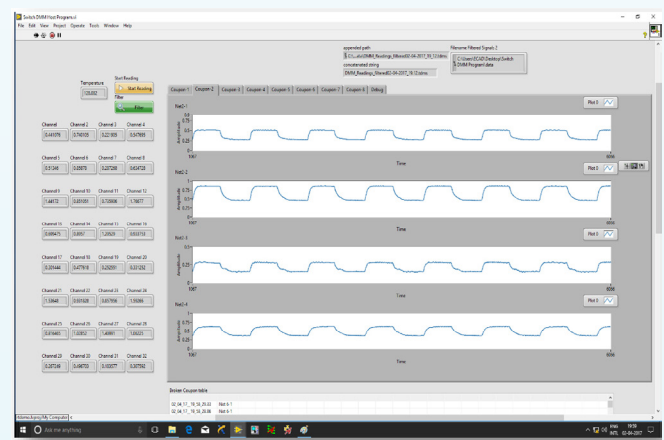

Front Panel of Software Application

## Advantages:

- Indigenously developed system,
- Quick in testing of samples (within 3.5 days),
- Highly configurable and scalable system and test parameters,
- System design as per the requirements of IPC-9151D standard,
- Simple and easy to operate, no specialized training required,
- Testing cost and duration are significantly less than foreign test service providers

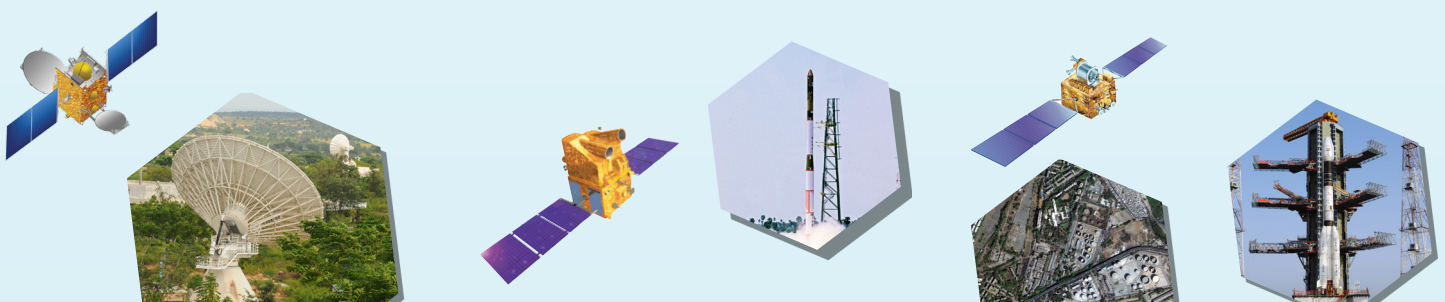

## Systems Operations:

The via reliability assessment is done by subjecting the PCB samples (coupons) to a thermal shock from  $-40^{\circ}\text{C}$  to  $+145^{\circ}\text{C}$  and vice versa, within 120 sec and maintaining the samples at extreme temperatures for 180 sec. This forms a single thermal cycle. The cycle is repeated for 500 times. Each PCB coupon has electrical circuits (nets) which are comprised of vias and trace interconnects. The precision 4-wire resistance of the each circuit is monitored and logged throughout the test. The peak resistance of each net is determined for every thermal cycle and percentage variation of second peak onwards is calculated with respect to very first peak. As per the IPC protocol, a variation of more than 10%, observed any time during the test, is not acceptable and that particular sample is deemed as failed. There is also a provision to conduct assembly preconditioning before the test, where the samples are subjected to 6 cycles of reflow soldering profile, so that assembly stresses are captured by the samples and any serious degradation is subsequently detected by the HATS test.

## Applications:

This test setup can be used for Batch Acceptance Tests for FM bare PCBs, Vendor Qualification, Material Qualification, Incremental Qualification, VOQ (verification of qualification), project specific qualification requirements, Qualification of new PCB technologies like HDI, Rigid-flex and Hybrid PCBs etc.

## Technology Transfer from ISRO

ISRO is willing to offer the knowhow of this technology to suitable entrepreneurs / industries in India. Capable manufacturing industries interested in acquiring this knowhow may write with details of their present activities, requirements and plans for implementation, infrastructure and technical expertise available with them, their own market assessment, if any, and plans for diversification to the address given below:

NewSpace India Limited (NSIL)

Email: [contact-nsil@isro.gov.in](mailto:contact-nsil@isro.gov.in)

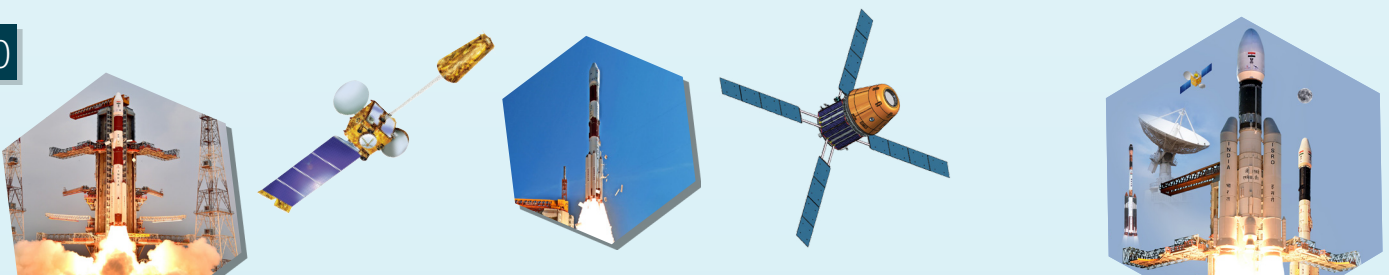

# Electronic Safety Handheld Ohmmeter (ESHO 4.5)

ESHO is a low voltage, low power electronic safety handheld ohmmeter for safe measurement of squib resistance.

## Salient Features

- Low power design – Operates at 1.5V
- Digital display for monitoring
- Wide range of measurement (0-20 k $\Omega$ )
- Better resolution (1m $\Omega$  in lower range)
- Inherently safe design – no energy storage components used in the squib line
- Maximum fault current in squib line limited to 10mA
- Health monitoring feature – Inbuilt battery voltage and multiplier circuit health monitoring

Range	Resolution	Accuracy & Repeatability	Nominal squib current
SRM (0-20 $\Omega$ )	0.001 $\Omega$	Better than 0.25% of Full Scale Range (FSR)	5.4mA
ISOLATION (0-20 k $\Omega$ )	1 $\Omega$	Better than 0.1% upto 10k $\Omega$ & better than 0.5% of FSR upto 20k $\Omega$	7.2 $\mu$ A

## Technology Transfer from ISRO

ISRO is willing to offer the knowhow of this technology to suitable entrepreneurs / industries in India. Capable manufacturing industries interested in acquiring this knowhow may write with details of their present activities, requirements and plans for implementation, infrastructure and technical expertise available with them, their own market assessment, if any, and plans for diversification to the address given below:

NewSpace India Limited (NSIL)

Email: [contact-nsil@isro.gov.in](mailto:contact-nsil@isro.gov.in)

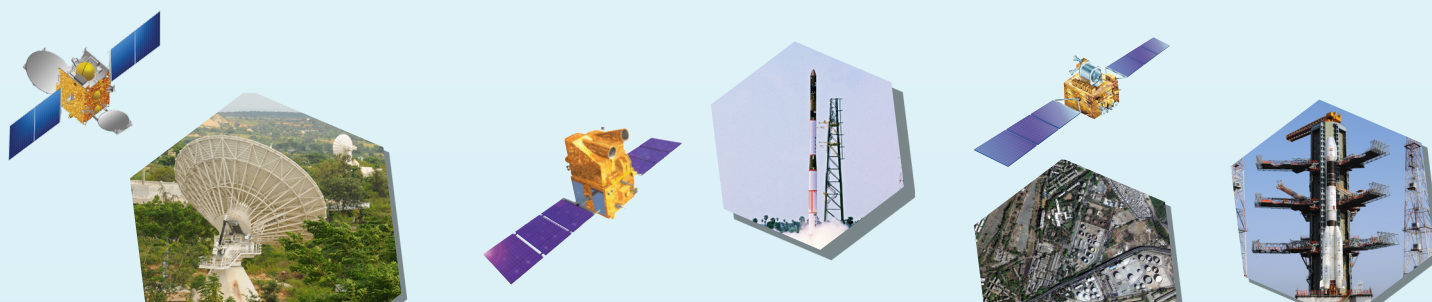

# Piezo-Electric Vibration Sensor (PEVS)

Piezo-Electric Vibration Sensor with in-built Electronics (PEVS) integrates piezoelectric crystals with electronics - a Charge-to Voltage Converter with Buffer. It has a simple integration process and provides millivolts output proportional to the - applied acceleration .

## Specifications

Parameter	Specification	Remarks
Voltage Sensitivity	25 mV/g	.
Range	$\pm 100g$	
Frequency range	20Hz to 2000Hz	
Mounted resonance	> 12 KHz	
Frequency flatness	$\pm 3\%$	upto 2kHz
Non-linearity	$< \pm 0.5\%$	
Lower Frequency cut-off	< 5 Hz	
Power Supply	$\pm 5V, 5mA$ or $\pm 15V, 5mA$	
Electrical interface	Pigtail wires	4-core , Twisted Shielded, 28AWG
Weight	36grams	1-metre pigtail

## Salient features

- Built-in electronics, eliminates external signal conditioning
- Ease of integration

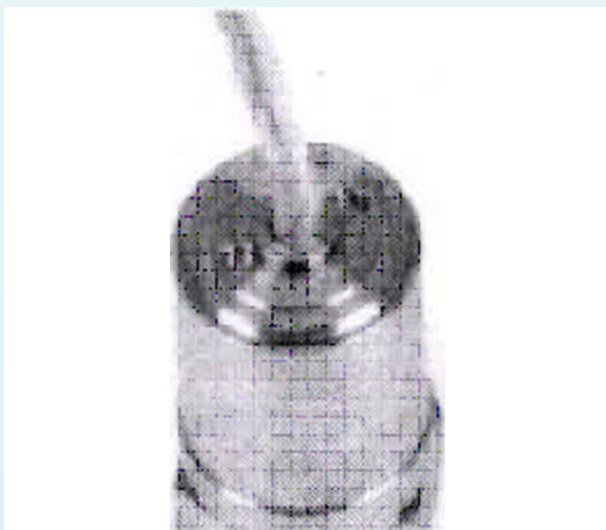

## Technology Transfer from ISRO

ISRO is willing to offer the knowhow of this technology to suitable entrepreneurs / industries in India. Capable manufacturing industries interested in acquiring this knowhow may write with details of their present activities, requirements and plans for implementation, infrastructure and technical expertise available with them, their own market assessment, if any, and plans for diversification to the address given below:

NewSpace India Limited (NSIL)

Email: [contact-nsil@isro.gov.in](mailto:contact-nsil@isro.gov.in)

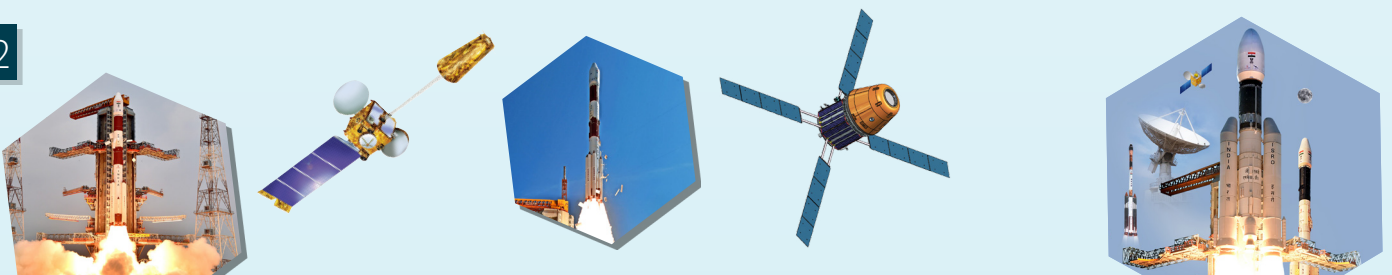

# Ribbon Stack Heat Flux Sensor

Ribbon stack heat flux sensor can be used for measuring heat flux upto 30W/cm<sup>2</sup>. The sensor is a thermopile type realised by stacking alternatively a series of Chromel and Alumel ribbons embedded inside a ceramic cement matrix. The construction is using metal ribbons, hence, it is named as Ribbon Stack Heat Flux Sensor..

## Salient Features

Type : Heat flux sensor

Sensor range : 0- 30W/cm<sup>2</sup>

Output : 0-20mV (linear)

Accuracy :  $\pm 6\%$

## Applications

Radiative and convective heat flux measurements in flight and ground use.

## Technology Transfer from ISRO

ISRO is willing to offer the knowhow of this technology to suitable entrepreneurs / industries in India. Capable manufacturing industries interested in acquiring this knowhow may write with details of their present activities, requirements and plans for implementation, infrastructure and technical expertise available with them, their own market assessment, if any, and plans for diversification to the address given below:

NewSpace India Limited (NSIL)

Email: [contact-nsil@isro.gov.in](mailto:contact-nsil@isro.gov.in)

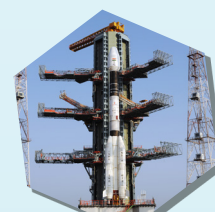
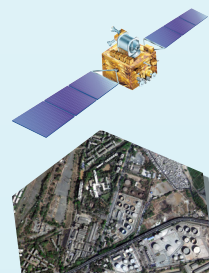
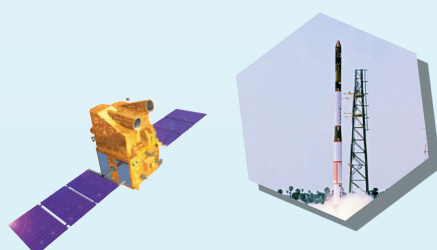
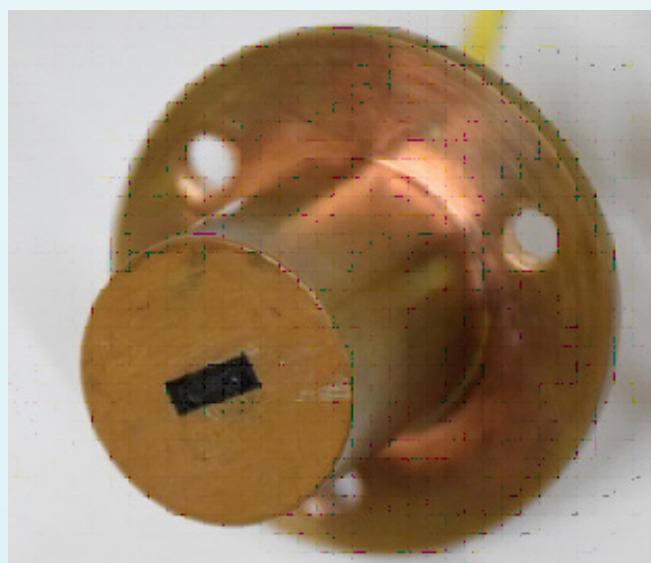

# Precise Timescale

ISRO Telemetry, Tracking and Command Network (ISTRAC) has developed a Precise Timescale which can act as the reference time for the satellite navigation constellations (e.g. NavIC, etc.) as well as for any other precise application such as national timekeeping (e.g. Generation of Indian Standard Time), VLBI, precise time dissemination for financial institutions etc

## Major Features

- Two user-selectable methods of Ensemble and steering, respectively
- Seamless integration of any type and any number of clocks
- Auto Steering using Time transfer data via GNSS/ NavIC Common View, TWSTFT and Manual steering using user inputs
- User configurable Steer Interval and Steer Time Constant
- Time transfer capability via GNSS/NavIC Common-view, TWSTFT
- Flywheel Mode in case of loss of reference
- Automatic and manual weight assignment for physical clocks
- Automatic Clock anomaly detection and corrective action
- Isolating the faulty clock from timescale ensemble
- UTC Measurement anomaly detection and corrective action
- Protection of user in case of timescale output non-availability
- Outputs generated: 5 MHz, 10 MHz, 1 Pulse per second, IRIG, NTP, PTP

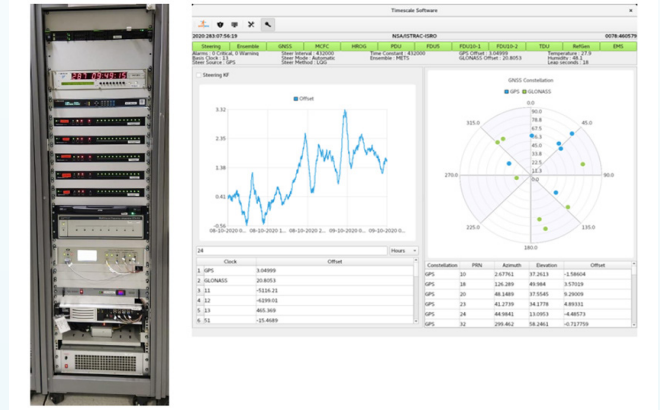

## Major Specifications

- Steered to Coordinated Universal Time (UTC) such that the difference  $|UTC-TS|$  shall be less than 30 ns ( $2\sigma$ ) for any yearly time interval. This requirement is compiled for both Automatic and Manual steering modes of timescales.
- The frequency offset of the timescale (normalized to UTC) :  $< 5 \times 10^{-15}$  ( $2\sigma$ ) averaged over a day.
- In case of non-availability of UTC, timescale is maintained in flywheel mode within an uncertainty of 20 ns, ( $2\sigma$ ) for at least 10 days.

## Technology Transfer from ISRO

ISRO is willing to offer the knowhow of this technology to suitable entrepreneurs / industries in India. Capable manufacturing industries interested in acquiring this knowhow may write with details of their present activities, requirements and plans for implementation, infrastructure and technical expertise available with them, their own market assessment, if any, and plans for diversification to the address given below:

NewSpace India Limited (NSIL)  
Email: [contact-nsil@isro.gov.in](mailto:contact-nsil@isro.gov.in)

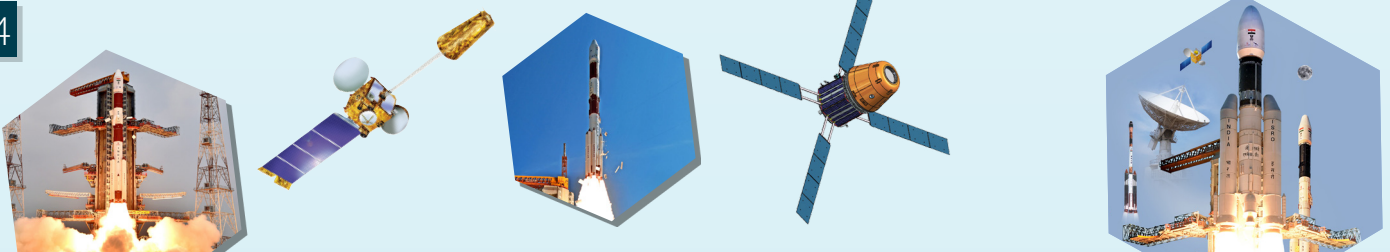

## CAL-VAL Systems For Spaceborne Ocean Colour Sensors

The CAL-VAL systems consist of a pair of buoy named "Optical & Met" in deep ocean & a robotic sun-photometer on the island. A discuss type wave following buoy, filled with Polyurethane foam, for deep sea application is used as a platform to mount the sensors. This buoy type has 2.2m diameter and 2100 kgs reverse buoyancy weight and a central pipe structure of 5m length with three 1.75m arms extending side ways.

**The in-situ parameters available are: optical, meteorological, biological, physical & atmospheric.**

### Objectives

ISRO has developed successfully CAL-VAL site at Kavaratti for India's OceanSat-II OCM-II sensor's

vicarious calibration and its geo-physical product validation. The recent observations from various instruments are analysed along with OCM-I & OCM-II radiance products and other contemporaneous satellite sensors.

### Potential utilization & applications of the site/data

- Vicarious in flight calibration of Ocean colour sensors
- Validation of OceanSat-II Geo-physical products
- Bio-optical algorithm development and its validation
- Time series studies and inter-sensor comparison
- Near real time data evaluation



NewSpace India Limited (NSIL)  
Email: [contact-nsil@isro.gov.in](mailto:contact-nsil@isro.gov.in)

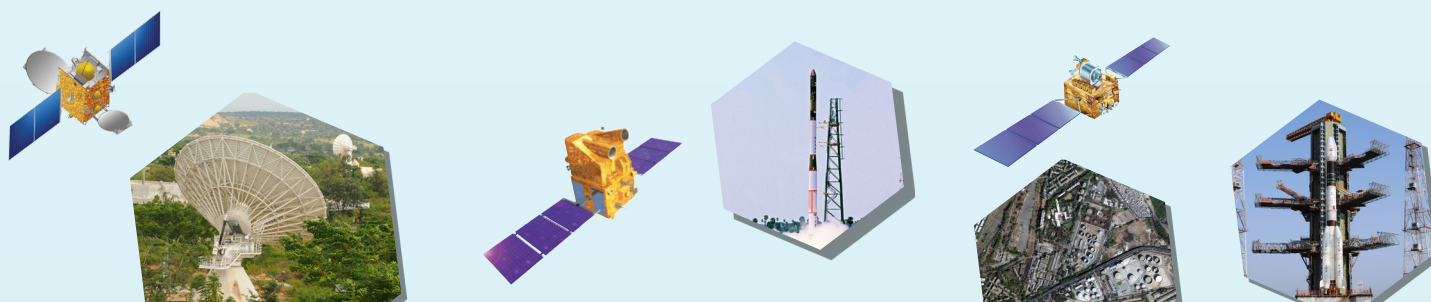

# Photosynthesis Irradiance Incubator

Space Applications Centre (ISRO), Ahmedabad has designed and developed a photosynthetic irradiance incubator (photosynthetron) for marine and fresh water applications. This is used to measure the photosynthetic-rate parameters (PI) of phytoplankton, the microscopic, photosynthesising green plants of the ocean. PI parameters constitute an important element for modelling and estimating oceanic primary production

- The chamber is filled with water which is continuously circulating. A temperature sensor monitors the temperature of the water bath, which helps in maintaining the desired ambient water temperature for the samples. The period of incubation of the sample is programmable.

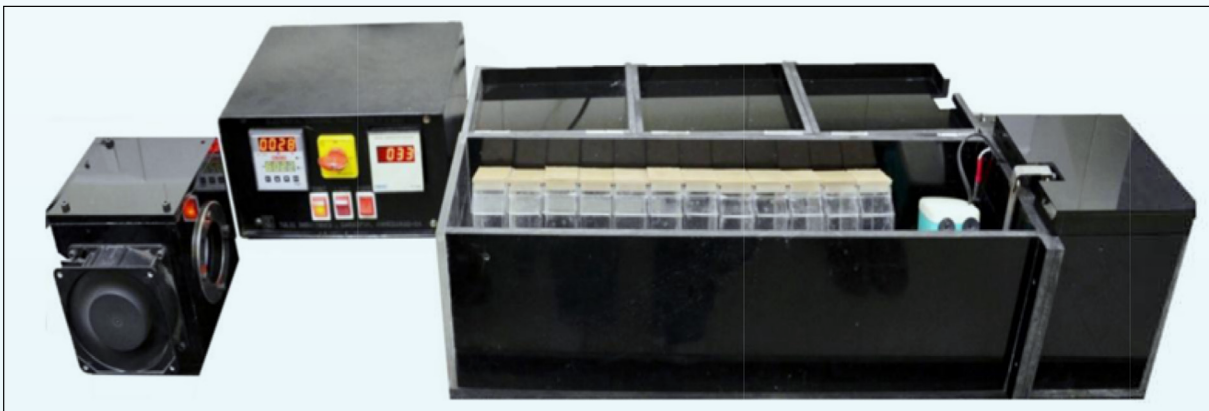

using remote sensing data. The major components of the photosynthetron are the main incubation chamber, source lamp, lamp housing chamber, flat rectangular bottles on a movable rack, temperature sensor, submersible pump, motor and gear box.

## Method of Operation

- The photosynthetron incubates a sample of phytoplankton with a tracer under controlled light gradient provided by a light source and a series of optical screens, designed to simulate light depths of aquatic environment.
- The incubation chamber houses linearly arranged twelve bottles on a rack containing phytoplankton sample and the rack is attached with a gear system for continuous tilting motion to allow phytoplankton to remain in suspension as in natural environment.

## Potential users

All laboratories, research institutes, universities involved in marine & oceanographic research especially in the area of primary production by phytoplankton and fisheries.

## Technology Transfer from ISRO

ISRO is willing to offer the knowhow of this technology to suitable entrepreneurs / industries in India. Capable manufacturing industries interested in acquiring this knowhow may write with details of their present activities, requirements and plans for implementation, infrastructure and technical expertise available with them, their own market assessment, if any, and plans for diversification to the address given below:

NewSpace India Limited (NSIL)  
Email: [contact-nsil@isro.gov.in](mailto:contact-nsil@isro.gov.in)

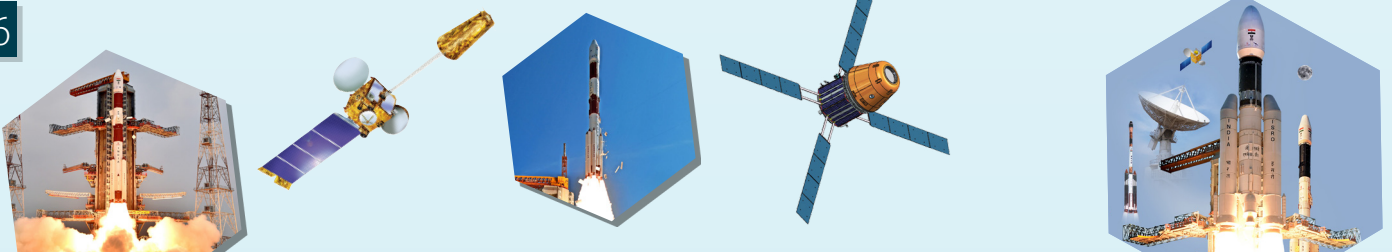



# Ground Penetrating Radar (GPR)

## Salient Features

- Based on stepped-frequency continuous wave (SFCW) approach, ultra-wideband (100%, i.e. bandwidth of 500MHz with centre-frequency of 500 MHz).
- Depth Resolution better than 30 cm.
- Integrated GPS for geo-tagging of the recorded data.
- Built using commercial components readily available in the market, thus increasing the prospects of using indigenously developed GPR instruments at much lower cost (20 times lower compared to imported versions) for commercial and scientific use.
- Total mass of the system is 10 kg out of which 5 kg is for electronics and antennas and the rest for the structure (can be further optimized). Power requirement of the instrument is 10 W.

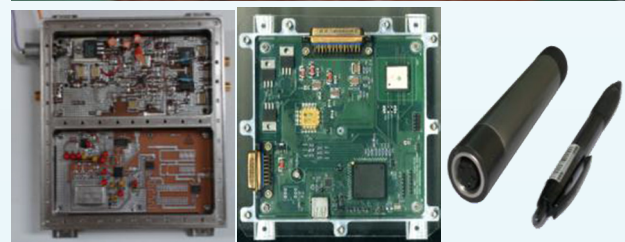

## Potential Applications

- GPR is a high resolution imaging radar that works on the principle of scattering of EM waves to locate buried objects. It operates by transmitting high frequency directly down into the ground via wideband antennas and detecting the reflected signals from targets (objects or materials with a dielectric contrast with the surrounding medium) buried beneath. It can be brought to use for the following applications:
- Can be brought to use for both commercial as well as scientific applications.
- GPR is an instrument that finds applications in environmental, engineering, archaeological, and other shallow investigations.
- Different applications require subtle changes in the hardware (frequency selection) as well as the processing software. Therefore once the exact application goal is defined the system can be tuned accordingly.

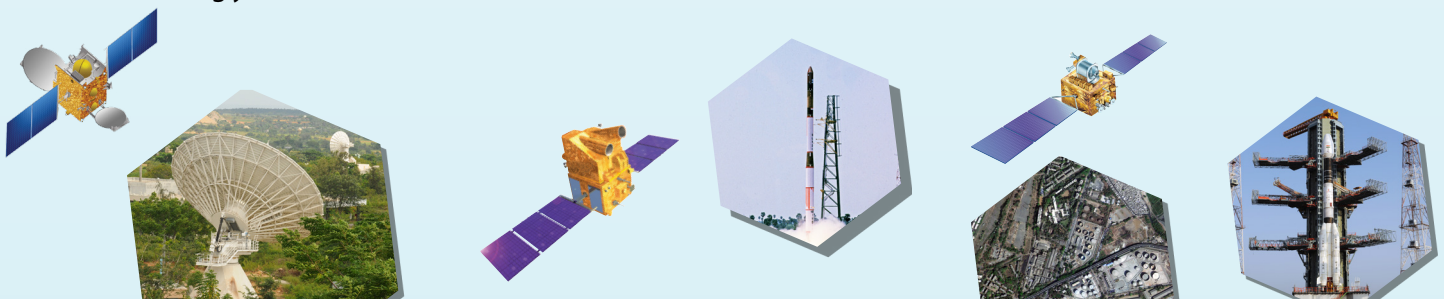
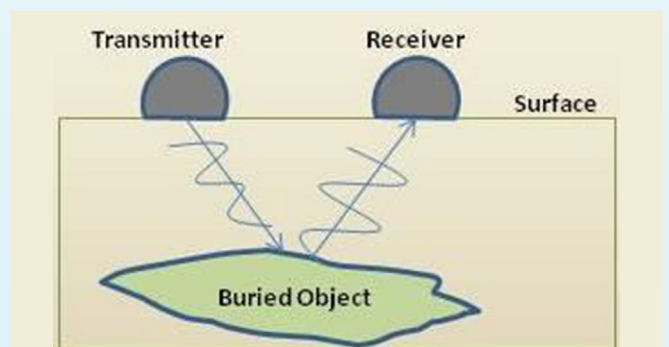

## Benchmarking with respect to Commercial GPR

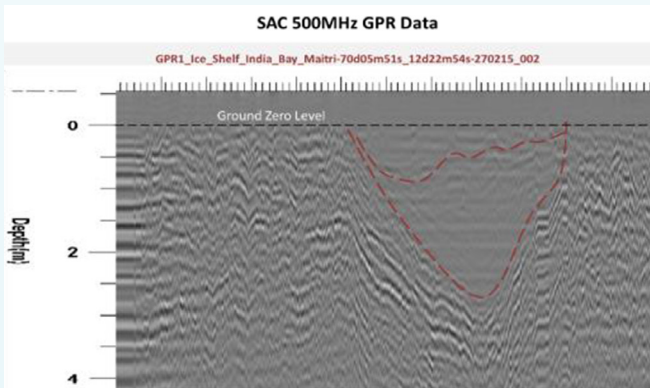
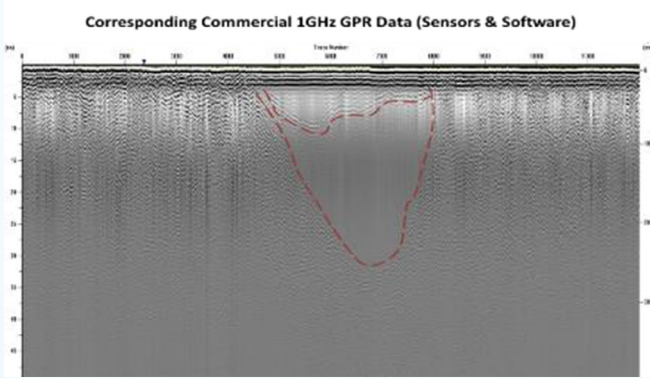

## Technology Transfer from ISRO

ISRO is willing to offer the knowhow of this technology to suitable entrepreneurs / industries in India. Capable manufacturing industries interested in acquiring this knowhow may write with details of their present activities, requirements and plans for implementation, infrastructure and technical expertise available with them, their own market assessment, if any, and plans for diversification to the address given below:

NewSpace India Limited (NSIL)

Email: [contact-nsil@isro.gov.in](mailto:contact-nsil@isro.gov.in)

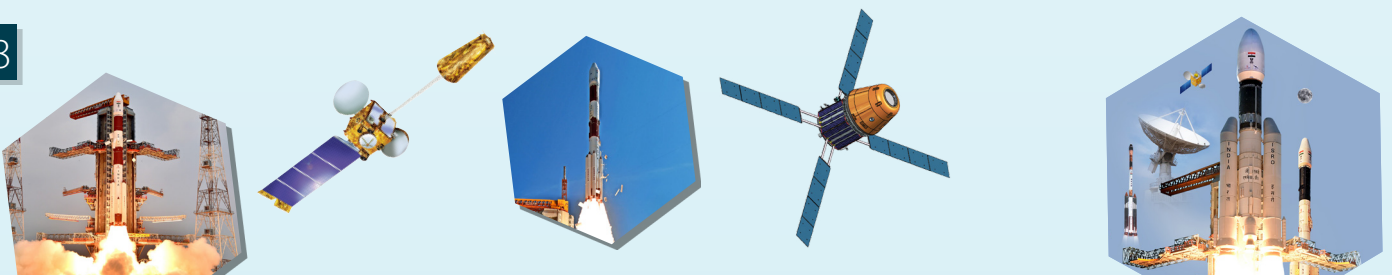

# Detection of Landslides from High Resolution Optical Satellite Data

Landslide is a geomorphic phenomenon; therefore, its identification is difficult to address in spectral domain alone using satellite/aerial datasets. The common noticeable feature after occurrence of landslides is the loss of vegetation and exposure fresh rock and soil. This unique property of a landslide in combination with its relationship with slope related parameters is used to create a generic routine in a COTS s/w, and is implemented through the following four sub-modules.

All the characteristic features of landslides derived from satellite data (e.g. NDVI, brightness) and DEM (e.g. slope, relief, curvature) were fused together in a series of steps comprising of controlled segmentation,

merging, classification, thresholding etc. To increase the robustness and transferability of the landslide, a data driven thresholding approach using K-means algorithm was employed. The knowledge-based approach was further strengthened by utilising change detection technique that increased the landslide detection accuracy from 76.4% to 96.7%. The minimum size of the landslide that can be detected using this method depends upon the resolution of the satellite data. However, using 5.8 m resolution data, a landslide of 774 sq. m was detected. The object-based landslide detection technology developed to detect landslides from segmentation to classification.

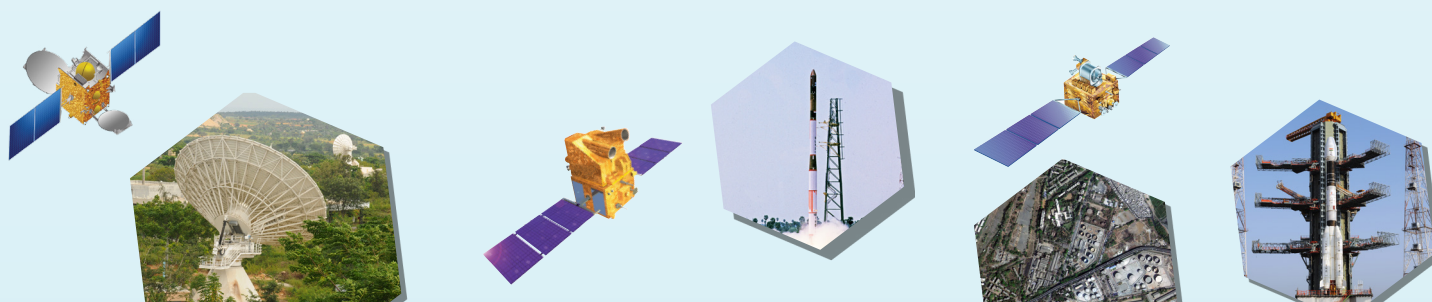
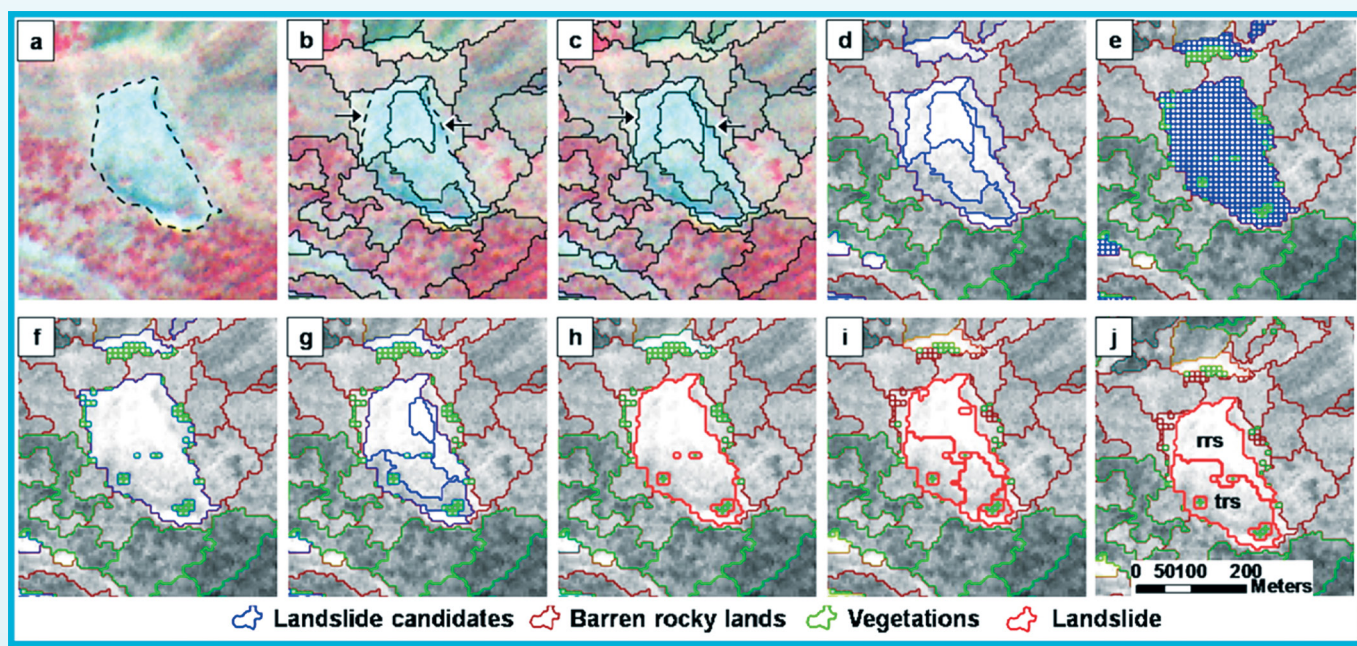

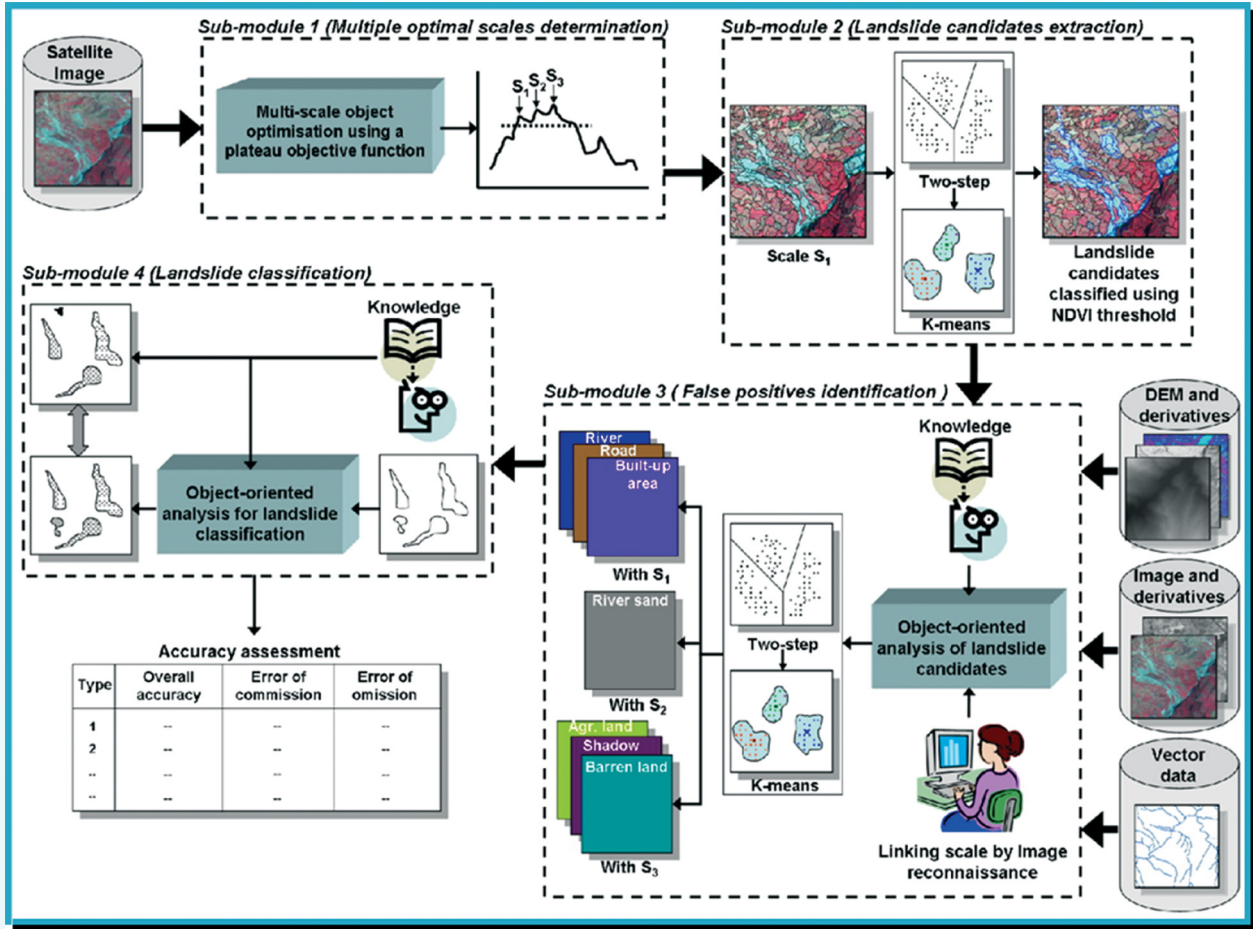

**Salient features:**

- This technique requires only high resolution optical satellite data. The technique combines spectral, shape, texture, morphometric and contextual information derived from high resolution Indian satellite data and DEM for the preparation of new as well as historical landslide inventories.
- The main innovative aspect lies in the selection of landslide diagnostic parameters and their use in the comprehensive characterization of different types of landslides, a concept which is addressed for the first time for detection of landslides in an object-based environment. Towards the development of a robust data driven methodology, a new POF was developed that was helpful in the multi-scale analysis of a terrain. Together with POF, and applying a change detection method using archived satellite data, a maximum landslide detection accuracy of

96.7% in Okhimath area of the Uttarakhand state could be achieved. The method has been validated in other mountainous terrains of India that has a different geological and geomorphological setup.

**APPLICATIONS**

- This technology will be used to create routine landslide inventor i.e e.g. on monthly or annual basis for large Himalayan region in India. This technology can also be used for land cover classification or vegetation change detection after suitable adaptation, since few land cover units such as barren land, agricultural land has already been identified as false positives to landslides.

NewSpace India Limited (NSIL)  
Email: [contact-nsil@isro.gov.in](mailto:contact-nsil@isro.gov.in)

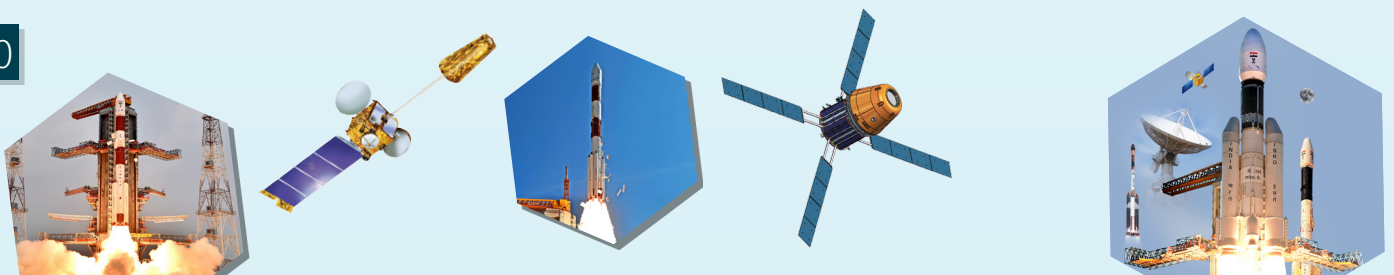

# SOFTWARE

## e-Smart

### e-System for Mechanical Workflow-Management And Reporting Tool

e-SMART is an online software tool to automate and provide seamless end-to-end workflow management from designer to delivery.

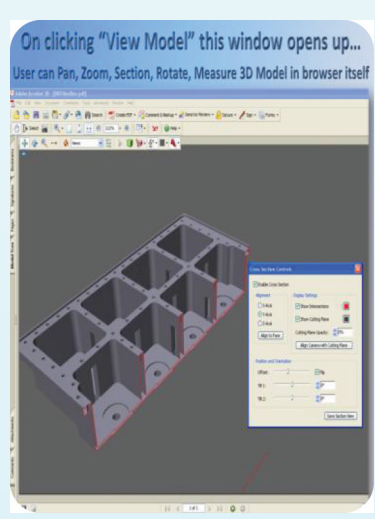
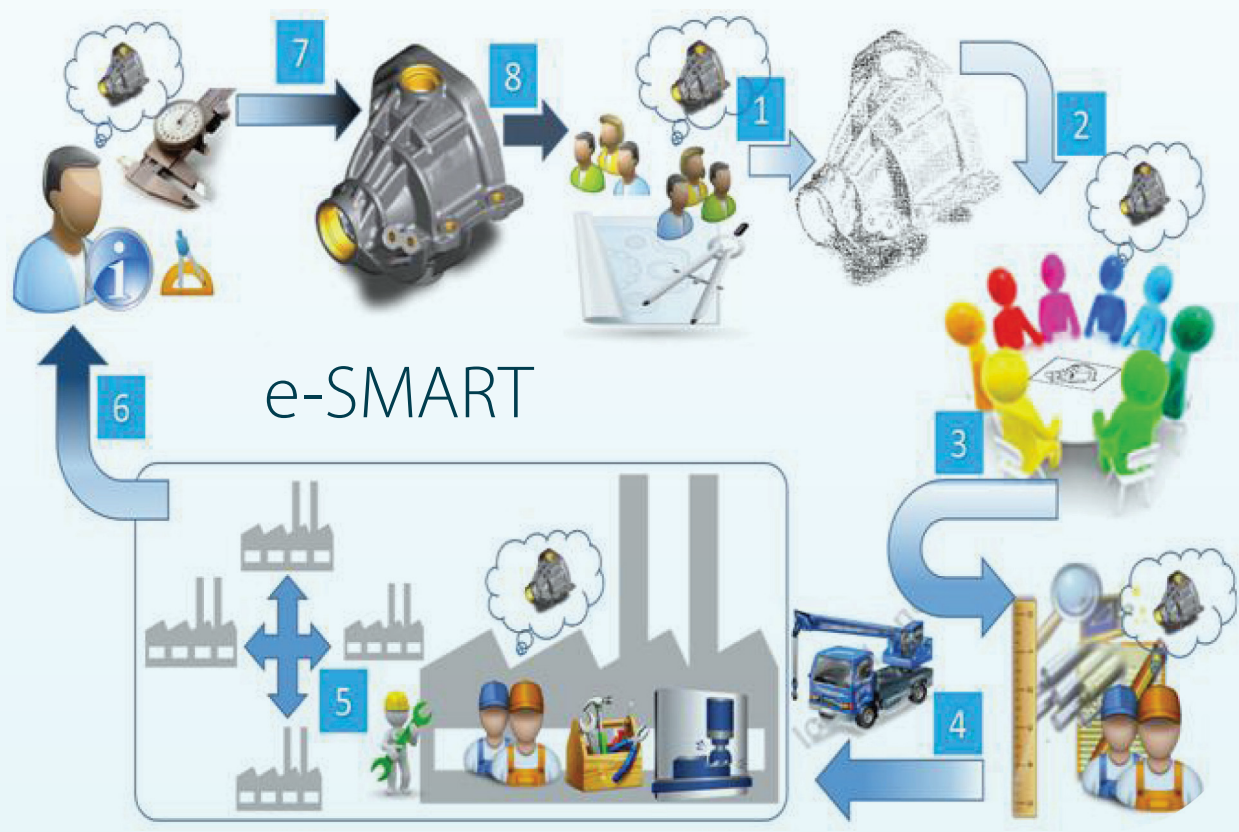
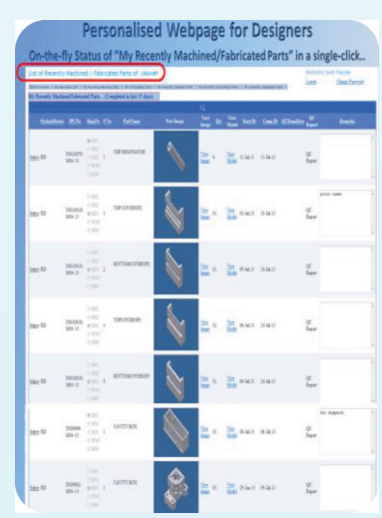



Personalised Webpage for Designers

On-the-fly Status of "My Recently Machined/Fabricated Parts" in a single-click..

List of Recently Machined/Fabricated Parts of Jobs

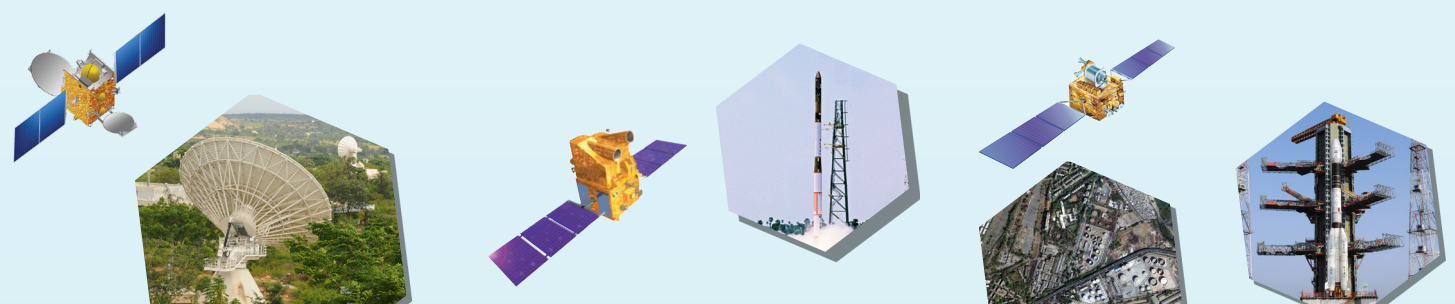
Part Name	Material	Qty	Unit	Job No	Job Date	Job Status	Job Location	Job Priority	Job Remark
...	...	...	...	...	...	...	...	...	...
...	...	...	...	...	...	...	...	...	...
...	...	...	...	...	...	...	...	...	...
...	...	...	...	...	...	...	...	...	...
...	...	...	...	...	...	...	...	...	...
...	...	...	...	...	...	...	...	...	...
...	...	...	...	...	...	...	...	...	...
...	...	...	...	...	...	...	...	...	...
...	...	...	...	...	...	...	...	...	...
...	...	...	...	...	...	...	...	...	...



Feature	Benefits
End-to-end workflow management	All departments like Designers, Planning Engineers, Workshop Engineers, Cutting-Store Personnel, Inspection Engineers and Management Personnel work on same platform
Simple and intuitive interface.	Easy to train manpower
Web based Scalable architecture	Saves on infrastructure costs. Remote facilities can be connected
User-level Authorization and authentication	Responsibility and accountability
Provision for Data-warehousing and automated daily-backup	Data protection
3D Visualization of fabrication parts in web browser	No commercial/paid CAD/CAM software required
Thumbnails (small images) of fabrication parts facilitate in quick visualization and identification	Increases productivity
More than 60 online reports can be generated and exported in multiple formats like .rpt, .xls, .doc, .xml	Critical Information for decision-making can be obtained
Back traceability of a part	Complete history of a part can be obtained
Paperless operations	Saves on cost and delays due to movement of papers

- ✓ ALL mechanical fabrication workflow activities of SAC are managed by e-SMART system.
- ✓ e-SMART is in use and operations in SAC for more than 7 years.
- ✓ Thus, it makes e-smart time tested and proven software.

## Technology Transfer from ISRO

ISRO is willing to offer the knowhow of this technology to suitable entrepreneurs / industries in India. Capable manufacturing industries interested in acquiring this knowhow may write with details of their present activities, requirements and plans for implementation, infrastructure and technical expertise available with them, their own market assessment, if any, and plans for diversification to the address given below:

NewSpace India Limited (NSIL)

Email: [contact-nsil@isro.gov.in](mailto:contact-nsil@isro.gov.in)

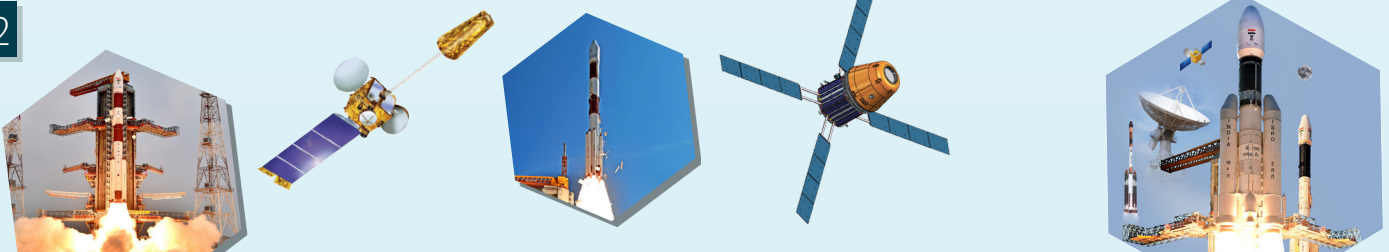

# Methods and system to control the data processing workflows in distributed environment with asynchronous message driven mechanism

A production workflow includes an ordered sequence of tasks to be executed that needs to be distributed on multiple computational nodes. Each task is assigned by a sender application to a receiver application running on a computational node through a message. On receiving the message, the receiver application sends and sends an acknowledgment to the message and schedules the sub tasks associated with the task. The sender application on receiving the acknowledgment removes the message from the queue otherwise the messages are stored in the database. On completion of the sub tasks the receiver application generates a message and the sender application on receipt of the message takes up the

next task in the sequence and generates a message to another application. The sender application keeps on generating messages till all the tasks are completed in the sequence. The methods adopted in this invention provides persistence and guaranteed delivery of messages thereby improving the quality of service in transaction processing systems that are managing complex workflows.

## Technology Transfer from ISRO

ISRO is willing to offer the knowhow of this technology to suitable entrepreneurs / industries in India. Capable manufacturing industries interested in acquiring this knowhow may write with details of their present activities, requirements and plans for implementation, infrastructure and technical expertise available with them, their own market assessment, if any, and plans for diversification to the address given below:

NewSpace India Limited (NSIL)  
Email: [contact-nsil@isro.gov.in](mailto:contact-nsil@isro.gov.in)

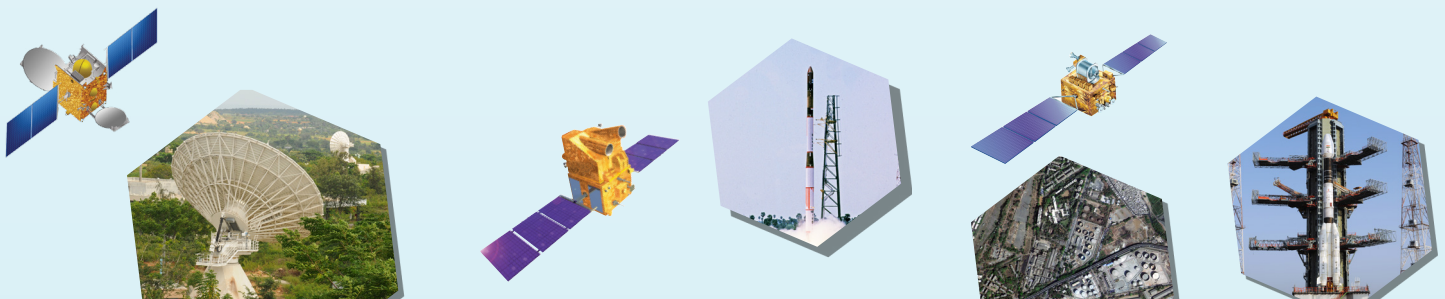

# Microwave Data Analysis Software (MIDAS)



Main GUI of MIDAS software MIDAS is copyrighted with registration number 13609/2020

Space Applications Centre (SAC) has developed in-house Microwave remote sensing data analysis software called Microwave Data Analysis Software (MIDAS). MIDAS is conceived and designed, to cater to various application driven analysis methods to analyse microwave remote sensing data. Currently it caters to SAR data analysis only, which includes different decomposition techniques for Full Polarimetry (FP) and Hybrid/Compact Polarimetry (CP). The software tool also has functional modules for doing radiometric quality analysis and impulse response analysis.

It has different speckle filters for SAR specific noise removal. It also includes techniques for glacier classification and facies detection, oil spill detection, ship detection etc. This software has been designed in a modular fashion to support new sensor data interfaces and the required application algorithms. Besides supporting ISRO sensors, MIDAS additionally, supports various SAR missions of other space agencies such as ALOS-1, RADARSAT-2, NASA-JPL UAVSAR and Sentinel-1.

## Main Capabilities:

- Written in C/C++
- Capable GUI in JAVA with Integrated image viewer.
- Polarimetric speckle filters integrated along with 11 amplitude filters
- Fast, modular and easily extensible
- Support for full-pol decompositions include H-A-Alpha, Pauli, Yamaguchi, Freeman-Durden and Raney (CP decomposition) etc.
- Full-pol Vanzyl type polarization response (polarimetric signature) generation module.
- ROI handling along with Wishart supervised classifier.
- Tools for Radiometric analysis & Impulse Response analysis.
- Sigma0, Gamma0 modules.

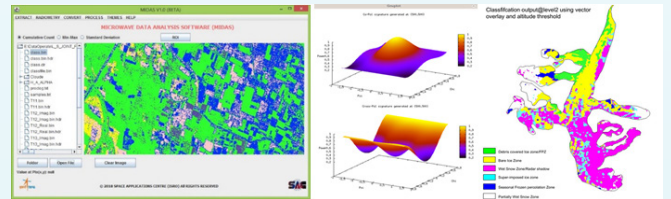

3D Point Cloud Depth Map Using this Camera

## Technology Transfer from ISRO

ISRO is willing to offer the knowhow of this technology to suitable entrepreneurs / industries in India. Capable manufacturing industries interested in acquiring this knowhow may write with details of their present activities, requirements and plans for implementation, infrastructure and technical expertise available with them, their own market assessment, if any, and plans for diversification to the address given below:

NewSpace India Limited (NSIL)

Email: [contact-nsil@isro.gov.in](mailto:contact-nsil@isro.gov.in)

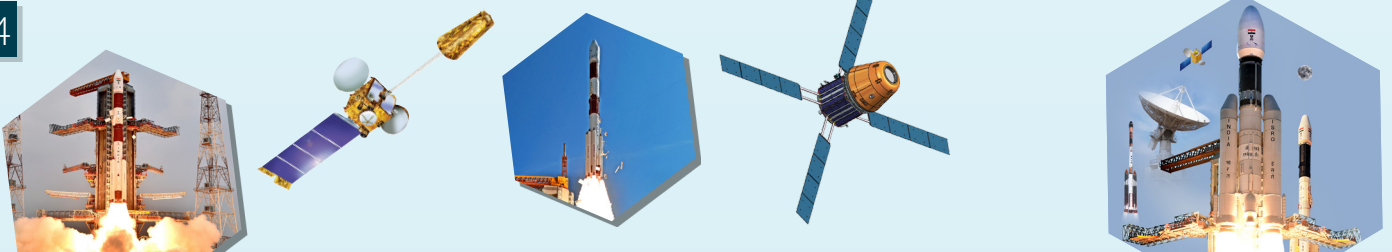



## Lithography and Patterning on Thin Film for Hi-Rel MIC

### Introduction:

Space Applications Centre (SAC) of ISRO has developed Lithography and patterning process on thin film for High-Reliability (Hi-Rel) Microwave Integrated Circuit (MIC) for space applications. This process fulfills RF/microwave properties like EM wave transmission/radiation, electrical conductivity, interconnection, corrosion protection, solderability, bondability etc. and making them a good base for mechanical strength along with thermal conductivity and thermal coefficient of expansion (TCE) matching with carrier plate on which substrate needs to be assembled.

These processes are qualified up to critical dimension (CD) of 100 micron for space use with very tight tolerances after subjecting to various tests like visual inspection, metal adhesion test, environmental tests etc. confirming to ISRO PAX-305 and MIL standards.

The salient features of the technology include process repeatability, patterning accuracy, defect density control and adhesion as per ISRO PAX-305 to ensure better yield. Presently, the developed process is being utilized for fabrication of subsystems for communication and navigation projects.

### Essential Infrastructure Requirements:

- Yellow Room of Class 100
- Clean room of Class 10000 and LAF for class 100 type
- Stereo Zoom Microscope up to 100 X magnification
- Wet processing work station
- Ultrasonic/Mega sonic cleaner
- Convection/Clean Air Oven/Hot plates

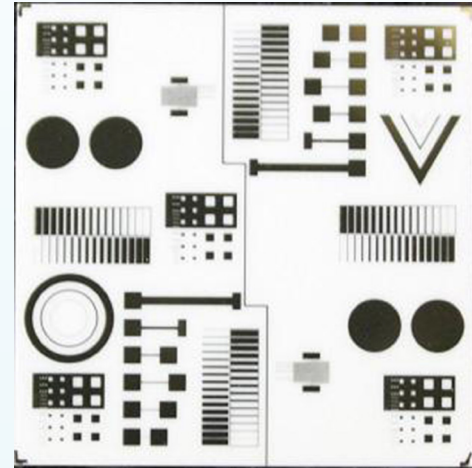

Phase-II Qualification sample  
(Patterned MIC)

- Spinner for Photoresist coating
- LASER direct write / UV Exposure system
- Weighing Balance
- DI Water system
- Chemical etching room with Fume hood and exhaust arrangement
- Nitrogen Purged, Temperature & Humidity controlled Storage Unit

### Material Requirements:

- Mask /Photo Film
- Metalized Alumina substrates (Coorstek make superstrate - 996 or equivalent).
- Cr-Cu-Au Metallization on both sides of substrates.
- Metallization thicknesses : Adhesion layer [Cr]: 200-250Å<sup>0</sup>  
Conductor [Cu]: 4.5 ± 0.5 μm  
Passivation layer [Au]: 1.5 ± 0.5 μ,  
Total Metallization thickness: 5-7 μm
- Sheet Resistivity: < 0.006 ohms/square or better.

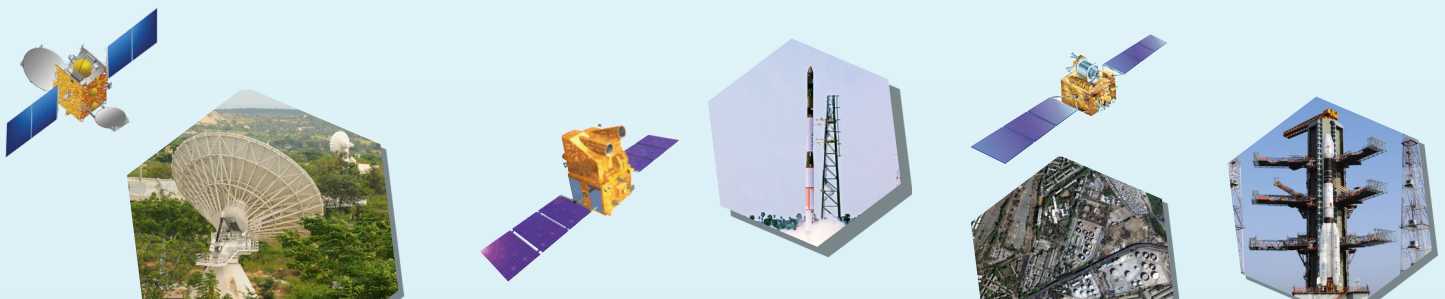

## Consumables Required:

- Cleaning solvents of electronic grade (EL): Trichloroethylene (TCE), Neutra-Clean 7, Dry IPA, Acetone and DI water (Resistivity > 5MΩ etc.)
- Photoresist: LPR E-1020, All resist AR N-4300
- Etchants:  $I_2$ , KI, NaOH,  $K_3Fe(CN)_6$
- Lint free tissue paper, cotton, scraper etc.

## Technology Transfer from ISRO

ISRO is willing to offer the knowhow of this technology to suitable entrepreneurs / industries in India. Capable manufacturing industries interested in acquiring this knowhow may write with details of their present activities, requirements and plans for implementation, infrastructure and technical expertise available with them, their own market assessment, if any, and plans for diversification to the address given below:

NewSpace India Limited (NSIL)

Email: [contact-nsil@isro.gov.in](mailto:contact-nsil@isro.gov.in)

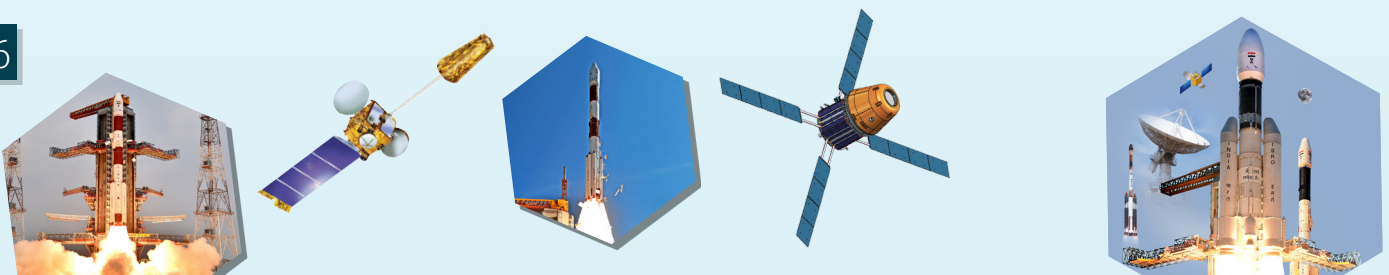

# Low Temperature Co-fired Ceramics (LTCC)

## circuit fabrication for satellite payloads

Space Applications Centre (SAC), Ahmedabad is a leading R&D Centre of Indian Space Research Organisation (ISRO) and is responsible for development and realisation of ground as well as satellite hardware required for various Communication, Navigation as well as Remote Sensing satellites.

SAC has well established and space qualified Low Temperature Co-fired Ceramics (LTCC) facility for the fabrication of High-Rel circuit and packages for various satellite payloads. SAC is also involved in the development of 3D integration and packaging for new applications.

Salient features of LTCC technology includes multilayer integration, embedded passives, easy hermetic sealing. It provides excellent SiP technology for integration of many technologies and devices for space applications.

### Essential Infrastructure Requirements:

- Clean room of Class 10,000
- Mechanical punching equipment
- Stencil and screen printer
- Hot air convection oven
- Stacker
- Isostatic laminator
- Sintering furnace
- Dicing equipment
- Microscope

### Preferable Infrastructure Requirements:

1. Stencil & screen manufacturing facility
2. Characterization tools
  - Tension meter
  - Four probe Sheet Resistivity meter
  - Density measurement tool
  - Flatness measurement tool
  - Stencil check system

### Material Requirements:

- DuPont 951 tape system: tape thickness 5/10 mil & compatible gold conductor and vias fill paste
- Ferro A6ME tape system: tape thickness 5/10 mil & compatible gold conductor and vias fill paste

### Technical Specifications:

Sr. No.	Specification	SAC Requirement
1	Conductor width	Minimum 4±0.5 mil
2	Via dimension	Minimum 4 mil ±10%
3	Via separation	Minimum 2.5 D (D - hole diameter)
4	Cavities	Step, blind and through cavities
5	Tape system	Ferro A6ME & DuPont 951
6	Maximum metal density	50% in all layer
7	Tape size	6.5" X 6.5", (8" X 8")
8	Metal scheme	All gold
9	Number of layers	10 & more

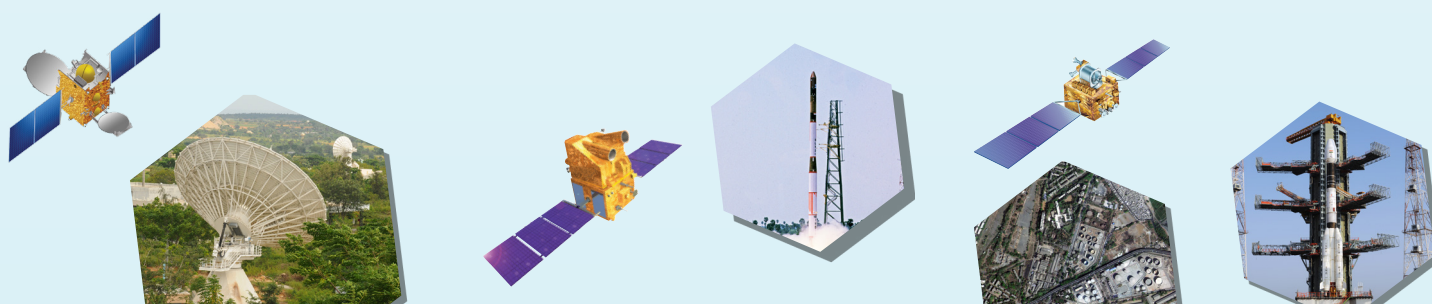

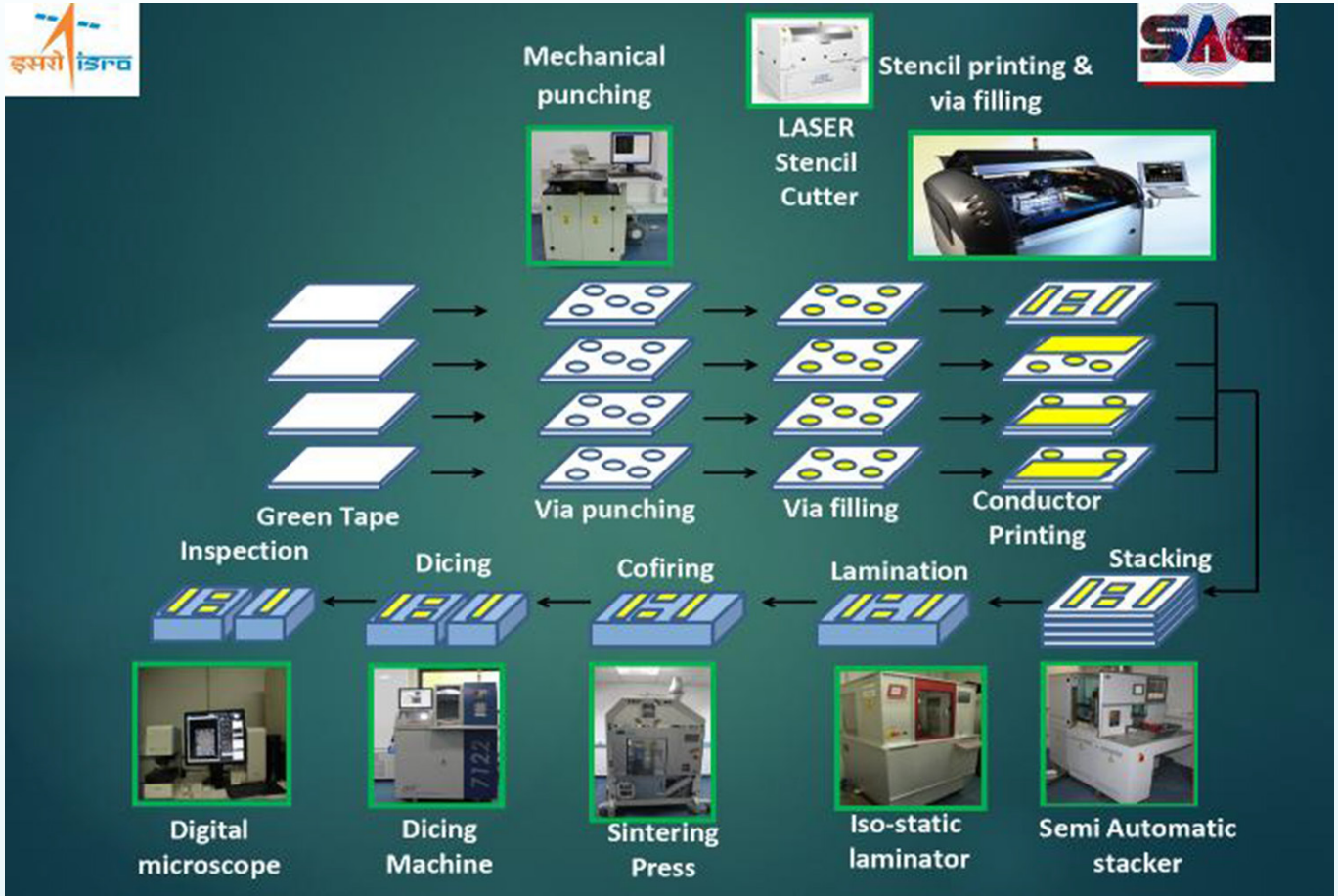

LTCC Process Flow

The developed product shall undergo extreme testing as per ISRO qualification standards and can be qualified for the space use only after successful completion of the testing. ISRO offers to transfer LTCC fabrication technology to industries in India with adequate experience and facilities. Enterprises interested in obtaining know-how may write giving details of their present activities, infrastructure and facilities to the following address

## Technology Transfer from ISRO

ISRO is willing to offer the knowhow of this technology to suitable entrepreneurs / industries in India. Capable manufacturing industries interested in acquiring this knowhow may write with details of their present activities, requirements and plans for implementation, infrastructure and technical expertise available with them, their own market assessment, if any, and plans for diversification to the address given below:

NewSpace India Limited (NSIL)

Email: [contact-nsil@isro.gov.in](mailto:contact-nsil@isro.gov.in)

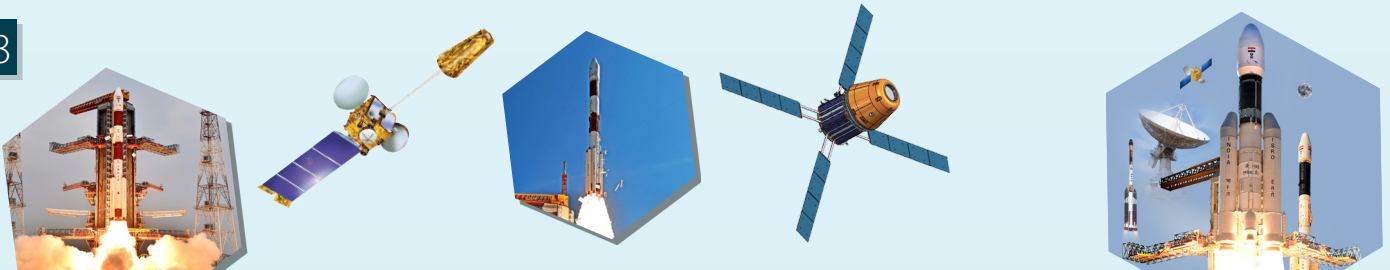

# Black Anodizing On Aluminum 6061T6 & Chromating Technology

Space Applications Centre (SAC) of ISRO has developed electroplating processes for space hardware to achieve required surface engineering properties like EMI/EMC, electrical conductivity, non-conductivity, corrosion protection, solderability, emissivity and making a good base for Thermal Control Coatings. These processes are qualified for space use with very tight tolerances and subjected to various tests like visual inspection, adhesion test, environmental tests, and engineering property specific tests confirming to ASTM and MIL standards.

SAC has developed Black anodizing on Aluminum 6061-T6 alloy process which will find commercial and industrial applications. The black anodizing on aluminum alloy components such as boxes, cavities, posts etc. are used for optical as well as communication payloads. This coating is corrosion resistant has

- emissivity > 0.9
- solar absorptance > 0.93
- optical reflectance < 1%

Electrolytic black anodizing is a two-step process where anodizing is carried out in step 1 and step 2 involves electrolytic coloring. It has very good color fastness and optical properties. It is regularly used on satellite.

Components for satellites, at times, require bare white anodizing for corrosion protection only and at times need yellow chromating for basic protection of Aluminum with conductivity. There are instances where some part of the components need chromating for conductivity and other need black anodizing for emissivity.

## Plating Specifications

Black anodizing thickness:  $25 \pm 3$  microns



## Pre-requisites

- Basic Electroplating know-how
- Electroplating set up including electrolytic baths, chilling plants, power supplies etc.

## Applications

- Decorative
- Engineering / Industrial
- To enhance the emissivity and corrosion resistance of Aluminum alloy components.

## Technology Transfer from ISRO

ISRO is willing to offer the knowhow of this technology to suitable entrepreneurs / industries in India. Capable manufacturing industries interested in acquiring this knowhow may write with details of their present activities, requirements and plans for implementation, infrastructure and technical expertise available with them, their own market assessment, if any, and plans for diversification to the address given below:

NewSpace India Limited (NSIL)

Email: [contact-nsil@isro.gov.in](mailto:contact-nsil@isro.gov.in)

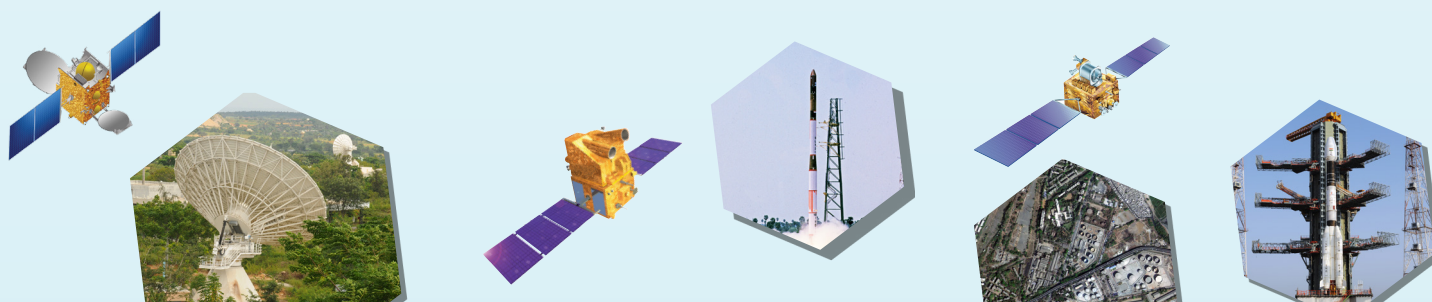

# Smart Fire Retardant Coating

A versatile solution to cater to wide gamut of external stimuli

Space Applications Centre of Indian Space Research Organization at Ahmedabad has developed an omni-purpose thin coating which can be applied easily on any substrate to obtain benefits in terms of fire retardant. This coating overcomes many of the limitations of commercially available paints.

## Potential Applications:

It can protect almost all type of materials. Hence, it may find applications in all type of finishing materials like wall panelling, false ceiling, doors, windows, walls. Its versatility makes it suitable for use in restaurants, hotels, hospitals, schools, Airports, shopping malls, metro stations, Bus hubs, Commercial buildings as well as personal residence.

## Advantages

- ✓ Provide two types of protections-fire resistance, flame retardant
- ✓ Has good adhesion to all surfaces
- ✓ Aesthetically appealing, can be mixed with any paint without loss of its fire retardant property
- ✓ Suitable for both indoor & outdoor use. Post curing will not wash off with rain water.
- ✓ Superior fire, thermal protection benefits.

## Special features:

- ✓ Can be applied as thin coating on any surface.
- ✓ Can be applied over existing surfaces after fire exposure.
- ✓ No surface preparation required except cleaning of dust and oil.
- ✓ Can protect from any mode of fire. Sustains high temperatures
- ✓ Saves substrates up to 50% after fire.
- ✓ Reduces moisture absorption by 50%

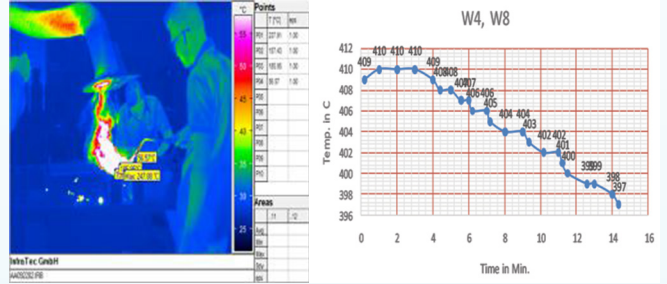

## Mode of application:

Can be applied like plaster by trowel. Any extensive training for application not required.

## Other Features:

- ✓ Good adhesion of the coating facilitates vertical and overhead application, minimizes clean up.
- ✓ Virtually free of maintenance, doesn't crack or deteriorate significantly with time.
- ✓ Dries to the touch approximately 2 to 4 hours after application and cures thoroughly in 48 hours in ambient temperature.

## Technical Specifications

Total Solids : 40 – 50%  
Color : Whitish Grey.  
Specific Gravity : 1.29 gm/cc.



Coated v/s bare wood specimen at 400°C

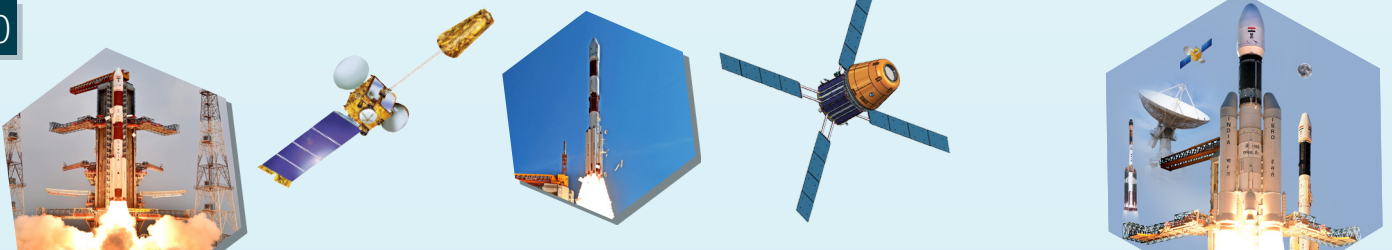

## Technology Transfer from ISRO

ISRO is willing to offer the knowhow of this technology to suitable entrepreneurs / industries in India. Capable manufacturing industries interested in acquiring this knowhow may write with details of their present activities, requirements and plans for implementation, infrastructure and technical expertise available with them, their own market assessment, if any, and plans for diversification to the address given below:

NewSpace India Limited (NSIL)

Email: [contact-nsil@isro.gov.in](mailto:contact-nsil@isro.gov.in)

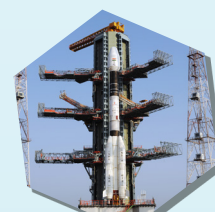
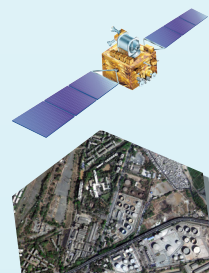
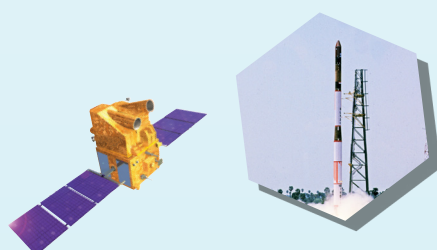

# Gold Plating on Aluminium 6061 T6 and Kovar

Space Applications Centre (SAC) has developed and qualified a robust gold plating process on Aluminum 6061T6 and Gold plating on Kovar for space use. These processes are qualified for space use with very tight tolerances on various process parameters after subjecting to various tests like visual inspection, adhesion test, and environment tests, and engineering property specific tests conforming ASTM and MIL standards.

Aluminum is gold plated for its unique combination of physical, chemical and electrical properties. The high electrical conductivity of gold, low contact resistance and good solderability combined with the consistency of these properties over wide range of environment conditions experienced by satellite makes gold plating the ideal choice for plating electronic hardware.

Kovar is used to fabricate carrier plates which act as support for MICs for use in communication payloads

## Specifications

Gold Plating on Aluminum 6061T6

Undercoat	Nickel-Phosphorous (Electroless Nickel)
Composition of undercoat	Nickel – Phosphorous (8-12%)
Undercoat thickness	10-12μ
Topcoat	Gold (Electroplating)
Type of Gold Plating	Acidic Gold Potassium Cyanide
Purity of Gold	99.99%
Thickness of Gold plating	2.5±0.5μ

Gold Plating on Kovar

Undercoat	Nickel (Electroplating)
Undercoat thickness	3-4μ
Topcoat	Gold (Electroplating)
Type of Gold Plating	Acidic Gold Potassium Cyanide
Purity of Gold	99.99%
Thickness of Gold plating	2.5±0.5μ

## SALIENT FEATURES

- This process is developed after undergoing intense qualification plans and tests to withstand harsh space-like conditions
- Acidic gold potassium cyanide plating process
- Easy to control and maintain
- Optimized for uniform and dense thickness

## APPLICATIONS

Gold plating is used in space grade mechanical components (Electronics circuit housing boxes, carrier plate etc). In electronics, gold plating is used to provide a corrosion-resistant electrically conductive surface. It is also used extensively in semiconductor industry e.g. in electrical switch contacts, connector pins and barrels and other applications where intermittent electrical contact occurs. Gold plating is generally practiced in aerospace applications.

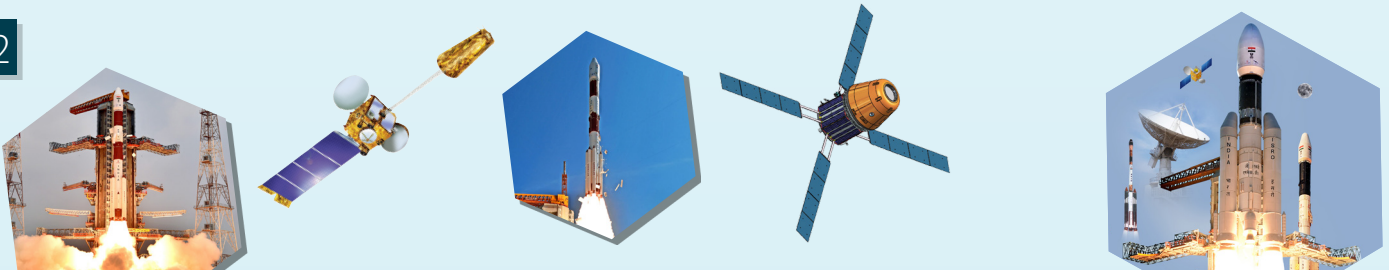



# Cr-Cu-Au metallisation for Hi-Rel MIC fabrication

Space Applications Centre (ISRO) is in the field of Microwave Integrated Circuits fabrication for communicational, remote sensing and navigational payloads. SAC has developed the process of Cr-Cu-Au (Chromium-Copper-Gold) metallisation on both sides (top and bottom side) of Alumina substrates using Magnetron sputtering techniques. The base material for MIC fabrication is dielectric ceramic viz. alumina on which the metallisation is to be carried out for MIC patterning.

The salient features of the technology include process repeatability, adhesion, uniformity, and compact structure of deposited thin film. The metallisation is expected to withstand environmental tests and demonstration of compatibility with further processes like pattern engraving and assembly and packaging. Presently, the developed process is utilised for fabrication of subsystems for ongoing IRNSS, GEOSAT and SCATSAT project activity.

## Essential Infrastructure Requirements:

- Clean room of Class 100 type
- Magnetron sputtering system with three cathode/ sputter gun configuration
- Ultrasonic cleaner
- Vapour degreaser
- Stereo Zoom Microscope up 100X magnification
- DI water plant

## Preferable Infrastructure Requirements:

- Thin film characterisation tools like

- High resolution Microscope upto 1000X magnification
- Four probe Sheet Resistivity meter
- Muffle Furnace
- Adhesion tester

## Material Requirements:

- Alumina substrates (Coorstek make superstrate-996 or equivalent)
- High purity sputtering Targets of Cr, Cu & Au
- High purity Argon gas
- Cleaning solvents of electronic grade like Acetone, TCE, IPA, HCL, Ammonia, DI water etc.

## Technical Specifications:

- Substrate: Alumina substrates
- Metallisation scheme:
  - Cr : ~ 300 Angstrom
  - Cu: 4 to 4.5 micrometer
  - Au : 2 to 2.5 micrometer
- Total thickness: 5 to 7 microns
- Uniformity :  $\pm 10\%$  on single substrates  
 $\pm 20\%$  batch to batch
- Metallisation required on both sides of substrates
- Sheet Resistivity: < 0.006 ohms/square

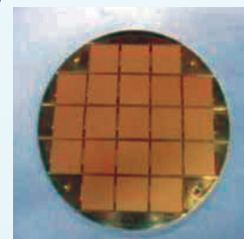

The developed product shall undergo extreme testing as per ISRO qualification standards and can be qualified for the space use only after successful completion of this testing.

ISRO offers to transfer this technology of Cr-Cu-Au metallisation on alumina substrates by Magnetron

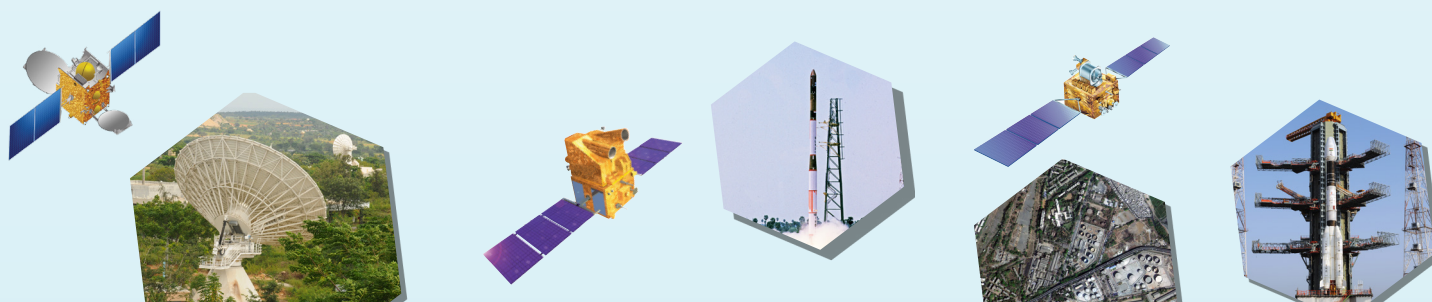



sputtering techniques for MIC fabrication to industries in India with adequate experience and facilities. Enterprises interested in obtaining knowhow may write giving details of their present activities, infrastructure and facilities to the following address.

## Technology Transfer from ISRO

ISRO is willing to offer the knowhow of this technology to suitable entrepreneurs / industries in India. Capable manufacturing industries interested in acquiring this knowhow may write with details of their present activities, requirements and plans for implementation, infrastructure and technical expertise available with them, their own market assessment, if any, and plans for diversification to the address given below:

NewSpace India Limited (NSIL)

Email: [contact-nsil@isro.gov.in](mailto:contact-nsil@isro.gov.in)

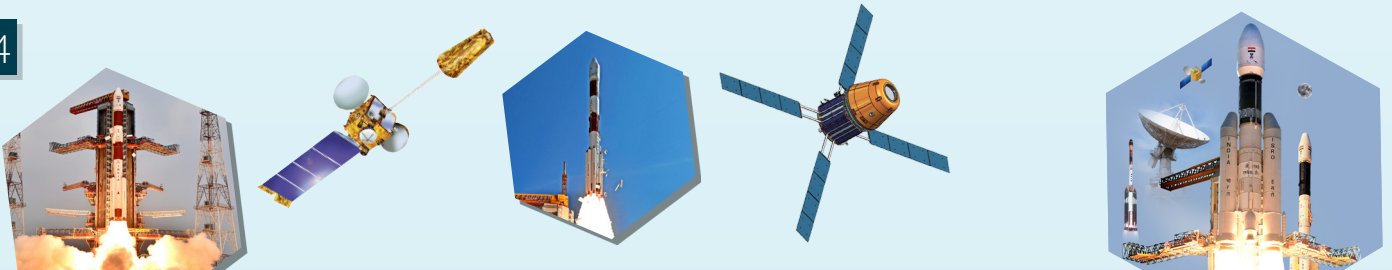

# Silver Plated Waveguides Technology

Space Applications Centre of Indian Space Research Organization at Ahmedabad has developed a method to carry out silver plating from inside in aluminum waveguides. It is a difficult task to plate due to the complexity and shape of the component. The purpose of this process is to get uniform deposition throughout the inside & outside surfaces of the component.

Silver plated waveguides are used in various communication payloads like GSAT, RISAT etc. Silver plating on Aluminum waveguides is required to obtain good RF performance, as silver gives the best known electrical conductivity and also is solderable.

Most commonly used space qualified paints are available normally in two colors, Black and White. Thermo-Optical properties of Thermal Control Coatings usually carried out are as per details given below:

The plated parts should be free of pits, nodules, blisters & roughness on the components. It should pass environmental tests like heat resistance, humidity, thermal cycling, thermo vacuum etc.

## Plating Specifications

*Electro less Nickel plating thickness: 6 to 8 microns*

*Silver plating thickness: 5 to 8 microns*



## Pre-requisites

- Basic Electroplating know-how
- Electroplating set up including baths, anodes, supplies etc

## Technology Transfer from ISRO

ISRO is willing to offer the knowhow of this technology to suitable entrepreneurs / industries in India. Capable manufacturing industries interested in acquiring this knowhow may write with details of their present activities, requirements and plans for implementation, infrastructure and technical expertise available with them, their own market assessment, if any, and plans for diversification to the address given below:

NewSpace India Limited (NSIL)

Email: [contact-nsil@isro.gov.in](mailto:contact-nsil@isro.gov.in)

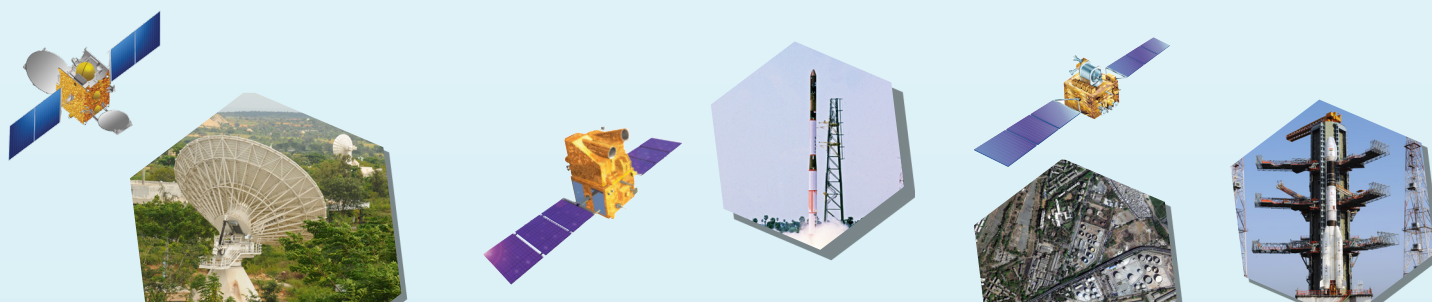

# Thermal Control Coating Technology

Space Applications Centre of ISRO has qualified the process of thermal control coating for spacecraft subsystem component made of different materials such as Anodized Aluminum, Chromated Aluminum, Bare Aluminum, Electroless Nickel plated Invar, Bare Invar, Silver plated Aluminum, Chromated Magnesium, Black anodic coated Magnesium etc for space use. Black paint is commonly utilized on the interior of the satellite, to facilitate radiant heat transfer among internal components.

Most commonly used space qualified paints are available normally in two colors, Black and White. Thermo-Optical properties of Thermal Control Coatings usually carried out are as per details given below:

Coating Type	Emissivity ( $\epsilon$ )	Solar Absorptive ( $\alpha$ )	$\alpha/\epsilon$
Black	0.90	0.90	1.00
White	0.85	0.20	0.23

## Terminal Specifications

Total Mass Loss (TML) :  $\leq 1.0\%$   
 Color : Black and White  
 Appearance : Flat / Matt finish  
 Dry Film Thickness (OFT) : 50 Micron to 70 Micron  
 Collected Volatile Condensable Material (CVCM) :  $\leq 0.1\%$

## Pre-requisites

- Painting know-how
- Conditioned Thermal painting booth
- Qualified paints, guns etc.

## Technology Transfer from ISRO

ISRO is willing to offer the knowhow of this technology to suitable entrepreneurs / industries in India. Capable manufacturing industries interested in acquiring this knowhow may write with details of their present activities, requirements and plans for implementation, infrastructure and technical expertise available with them, their own market assessment, if any, and plans for diversification to the address given below:

NewSpace India Limited (NSIL)  
 Email: [contact-nsil@isro.gov.in](mailto:contact-nsil@isro.gov.in)

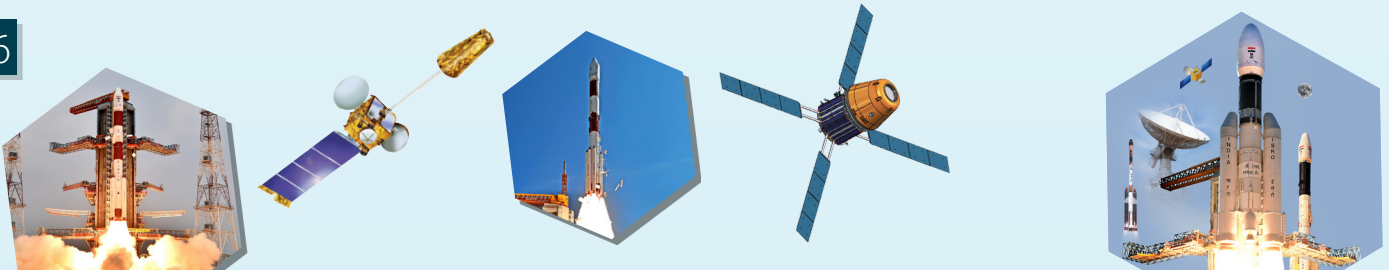

# Flameproofing Coating-Caspol

## Introduction

CASPOL (Ceramic-Polymer hybrid) is a water based, ready-to-coat and easy-to-use flame proof coating having both societal and advanced end-use applications. It confers excellent flame retardant, waterproofing and thermal control properties to substrates ranging from masonry surfaces, textiles, paper, thatched leaves, wood etc. to advanced materials like polyurethane and phenolic based thermal insulation foam pads.

## Salient features of CASPOL are:

1. No liquid or vaporizable material (except water)
2. Human and eco-friendly
3. Brushable and sprayable
4. Low cost

## Description

CASPOL is a room temperature curable, water based formulation having self-extinguishing properties, good adhesion and water repellency characteristics. It is based on ceramic composition dispersed in an aqueous polymeric emulsion containing flame retardant components. All the ingredients are dispersed in water to get a suspension of the required viscosity for application by brushing or spraying. It is having limiting oxygen index (LOI) above 40. The material coated with CASPOL will be self-extinguished within 4 seconds after removal of flame. It is also having good adhesion to the substrate surface both in the dry condition and after exposing the coated forms in water shower. Foam materials can be impregnated with CASPOL by dip coating.



**Fig. 1 Model huts made of thatched coconut leaves set to fire. (Left)-Hut without CASPOL coating gutted completely in fire within a few seconds whereas CASPOL coated hut remained intact even in fire.**

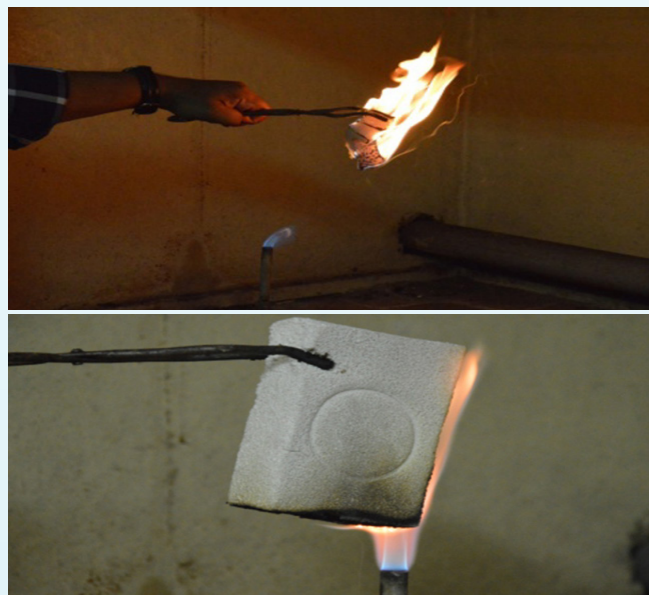

**Fig. 2 Images of commercial polyurethane foams set to fire. (Left)-foam without CASPOL impregnation burned completely in fire within a few seconds whereas CASPOL impregnated foam (right) remained intact even in fire.**

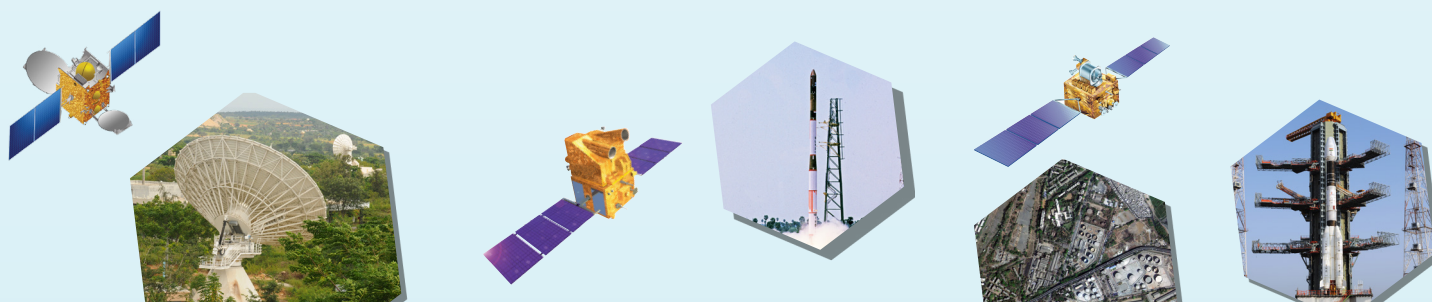

## Applications of CASPOL

1. **Launch vehicle:** CASPOL is a flame proof coating, giving the required flame retardant properties to thermal protection foam pads used in Launch Vehicles.
2. **House hold:** CASPOL can be applied over thatched leaves of the cottage roof to flameproof it in addition to increasing the life of such roofing of households, so that periodicity of the maintenance and replacement can be reduced significantly. Application of CASPOL reduces the temperature inside the room and prevents water leakage. The low solar absorptivity (0.20%-0.40%) and high emissivity make it a good temperature controller in sunny weather
3. **Waterproofing/thermal control of concrete:** CASPOL can be applied over the concrete surface of a building to prevent water seeping. The high emissivity keeps the building cool by at least 5 to 6°C less. After the application of CASPOL, water seepage problems will not be felt as CASPOL pots micro cracks and holes.
4. **Railways and automobiles:** CASPOL can be used as a flame retardant material in railways and automobiles where the seat cushions can be made flameproof using this material, without affecting the cushioning characteristics significantly.
5. **Foams In Public Transport:** If the foam materials used in passenger seats are rendered flameproof, fire accidents can be reduced to a large extend. Since flame proofing of foam materials using CASPOL can be achieved through less expensive processes, there is considerable market potential for CASPOL in Indian foam market.

Properties	CASPOL- alone	CASPOL coated PIPhenotherm/ Polyurethane
LOI, %	32-42	32-42
Solar absorptance	0.20-0.40	0.20-0.40
Adhesion tape test at RT	N/A	pass
Oxyacetylene flame test, time for extinction, sec	N/A	≤ 4 sec
Ignitability	N/A	Not easily ignitable
Surface spread of flame	N/A	Class 3
Heat release rate	N/A	53.83 kW/m <sup>2</sup>
Fire propagation index	N/A	17.97
Sensitization to skin	No sensitization	N/A
Irritation to skin	Non-irritant	N/A
Toxicity	Cytotoxic	

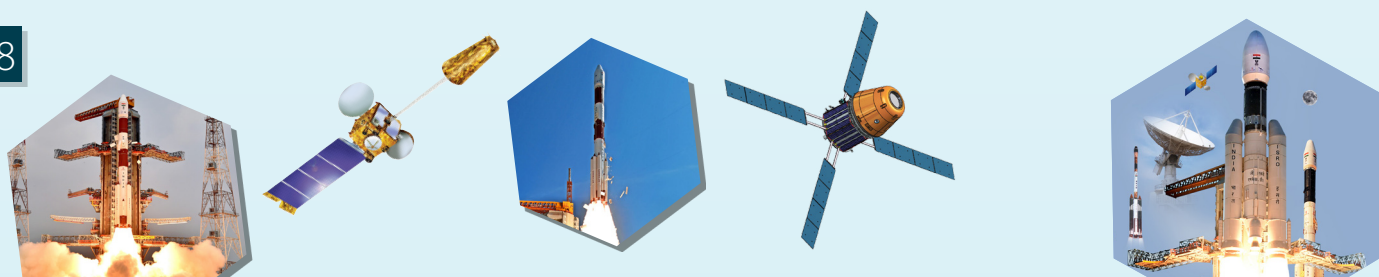



**Fig. 3 Two images of commercial seat cushion set to fire. In each image: (Left)-cushion with CASPOL impregnation remain intact even after fire whereas cushion without CASPOL impregnation (Right) is burned completely in fire within a few seconds**

CASPOL can also be used for flame proofing foam materials used in auditoriums and cinema halls where chances of fire related accidents are high.

VSSC is willing to offer the technology of CASPOL to capable and interested parties who are in the field of manufacturing similar items.

Interested entrepreneurs are requested to contact the address given below with all relevant particulars regarding their line of current activity, infrastructure available, market assessment of the product, financial arrangements strength of the company, turn over and sales of their products for the past few years and a copy of their latest annual report.

### Technology Transfer from ISRO

ISRO is willing to offer the knowhow of this technology to suitable entrepreneurs / industries in India. Capable manufacturing industries interested in acquiring this knowhow may write with details of their present activities, requirements and plans for implementation, infrastructure and technical expertise available with them, their own market assessment, if any, and plans for diversification to the address given below:

NewSpace India Limited (NSIL)

Email: [contact-nsil@isro.gov.in](mailto:contact-nsil@isro.gov.in)

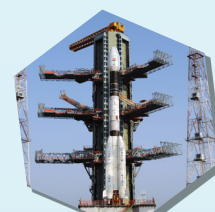
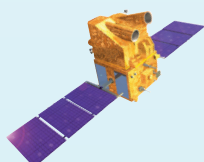
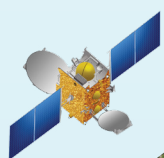

# Corrosion Resistant Coating NRCM-204

NRCM-204 is a corrosion resistant coating material for metals and composites to protect from various environments like nitric oxide, dinitrogen tetroxide ( $N_2O_4$ ), mixed oxides of nitrogen, concentrated nitric acid (Conc. $HNO_3$ ) etc. The system is comprised of inorganic-organic hybrid network consisting of hydroxy siloxane, epoxy-amine based alkoxy silanes, crystoballite silica. Complete curing of the system is achieved by simultaneous curing of epoxy-amine and hydroxy siloxane-alkoxy silane in presence of tin based catalyst.

## Salient Features

- Ambient temperature curing
- Corrosion resistant material to protect from harsh oxidizing environment

## Properties

LSS (Al/Al) at RT, ksc	: □10
Tensile strength, ksc	: □5
Tensile Modulus, ksc	: 5 to15
Elongation (%)	: 70 to120
Dip test of coating in Conc. $HNO_3$ for 3 days	: No Peel off

## Applications

NRCM-204 offers a highly corrosive resistant coating which can be coated over metals and composites for almost all type of corrosion which includes various acids. Conventional polymeric materials will not withstand such a highly corrosive environment.

## Technology Transfer from ISRO

ISRO is willing to offer the knowhow of this technology to suitable entrepreneurs / industries in India. Capable manufacturing industries interested in acquiring this knowhow may write with details of their present activities, requirements and plans for implementation, infrastructure and technical expertise available with them, their own market assessment, if any, and plans for diversification to the address given below.

NewSpace India Limited (NSIL)

Email: [contact-nsil@isro.gov.in](mailto:contact-nsil@isro.gov.in)

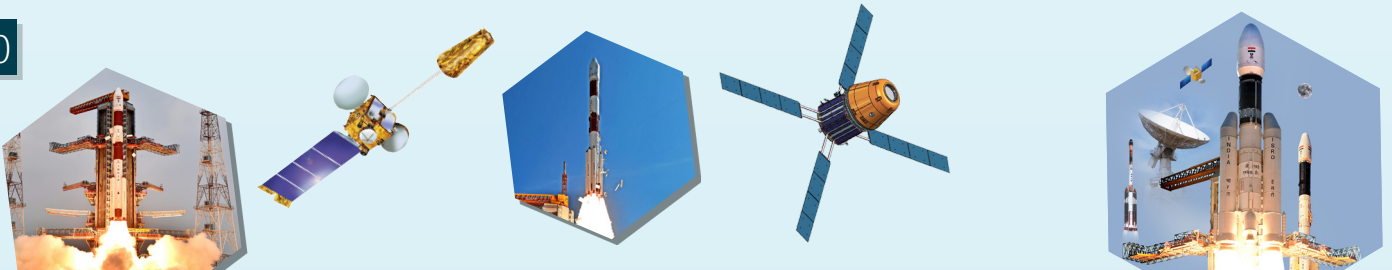



# Silicone polymer based thermal protection system : PC-10 TPS (Red) and (White)

PC-10 thermal protection systems are silicone polymer based filled compounds, which are good ablative thermal insulators. These compounds are room temperature curing systems which can be applied by brushing, spraying and putty blade. The remarkable features of the system include good thermal, chemical and ageing resistance and compatibility with wide variety of substrates. Indian Space Research Organisation (ISRO) at its Vikram Sarabhai Space Centre (VSSC) has developed a technology for processing and application of different types of silicone polymer based thermal protection systems with tailored properties to meet various mission/application requirements.

The processing involves incorporation of selected quality fillers and ingredients in specific type of silicone polymer resin and use of suitable curatives to achieve desired thermo-physical properties.

## Salient Features

- Simplified and cost-effective technology for processing premium quality ablative thermal protection systems
- Over night, room temperature curing system.
- Flexibility with respect to application procedure such as spraying, brushing or putty application.
- Compatibility with wide variety of substrates including metals, composites, glass etc.
- Excellent ageing behaviour and hydrophobicity, making it suitable for long term application with no deterioration of properties for more than 5 years.

## Applications

- Useful for high quality ablative thermal protection system for temperatures up to 350°C direct exposure with reasonable stability and capability to

retain properties. The system also has good moisture resistance and good age resistance. The system can be applied to desired thickness depending upon the thermal environment envisaged. Reasonable mechanical strength and adhesive properties with large number of substrates has been demonstrated by the system. Ability to retain properties at temperatures up to 150°C and low temperature flexibility are other highlights of the system owing to the low glass transition characteristics associated with silicone polymers.

- The products can be used for thermal protection application for protecting rocket hardware from aerodynamic heating and launch pad components from flame impingement and also as moisture / water impermeable coating etc.
- The system can be tailored for use as corrosion protection coating on metal substrates for outdoor use.

## Technology Transfer from ISRO

ISRO is willing to offer the knowhow of this technology to suitable entrepreneurs / industries in India. Capable manufacturing industries interested in acquiring this knowhow may write with details of their present activities, requirements and plans for implementation, infrastructure and technical expertise available with them, their own market assessment, if any, and plans for diversification to the address given below.

NewSpace India Limited (NSIL)

Email: [contact-nsil@isro.gov.in](mailto:contact-nsil@isro.gov.in)

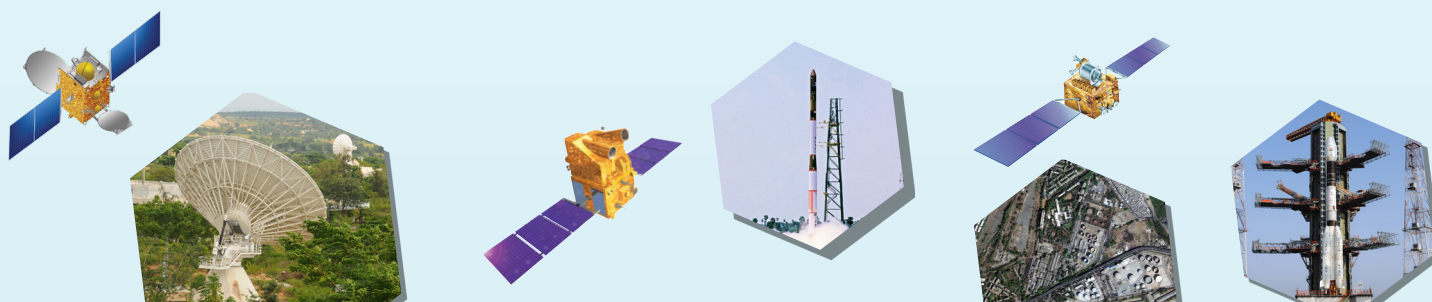

# High Emissive Silicone Coating, HESC/CSNM-29

Vikram Sarabhai Space Centre has developed a good number of specialty coatings to meet the specific requirements in Launch Vehicles and Satellites. These coatings may also find various industrial applications.

HESC/CSNM-29 is one such special coating system developed as a high temperature resistant enamel coating. This coating finds application as a high emissive topcoat on ablative surfaces. It is also used as a high emissive and thermal insulative coating on the PCB sensor cards for GPS Radiosonde studies. This room temperature curable silicone based coating system contains special inorganic fillers, which imparts high emissivity to the system. Other applications could include anticorrosion and weather/ rain proof coating on metallic substrates. The coating is weather and high temperature resistant and lasts for long.

### Typical Properties / characteristics:

PROPERTY	
Part A	White, viscous
Part B	Transparent liquid
Ford cup viscosity (Ford cup No. B 4)	20-40 sec. after diluting with 200 ml toluene
Adhesion tape test	No peeling from substrate

## Technology Transfer from ISRO

ISRO is willing to offer the knowhow of this technology to suitable entrepreneurs / industries in India. Capable manufacturing industries interested in acquiring this knowhow may write with details of their present activities, requirements and plans for implementation, infrastructure and technical expertise available with them, their own market assessment, if any, and plans for diversification to the address given below:

NewSpace India Limited (NSIL)

Email: [contact-nsil@isro.gov.in](mailto:contact-nsil@isro.gov.in)



# FB-CVI for realisation of C-C Composite

Indian Space Research Organisation (ISRO) at Vikram Sarabhai Space Centre has developed Film Boiling Chemical Vapour Infiltration (FB-CVI) technology for realisation of Carbon-Carbon Composite products. Carbon-Carbon composites materials possess excellent thermo-mechanical properties apart from excellent ablation and erosion properties, which are prerequisite for numerous high temperature applications. In addition, Carbon-Carbon Composites possesses ideal characteristics of low density, tailorable thermal conductivity, high heat absorption capacity, dimensional stability at high temperature, tribological properties and biocompatible characteristics making it suitable for a wide spectrum of applications. The process of FB-CVI enables realization of Carbon-Carbon Composite products through a faster process methodology and is adaptable for manufacturing of C-C Composites products for diverse applications.

## Salient Features of Film Boiling CVI process Technology

1. Simplified and Cost-Effective technology for manufacturing Carbon-Carbon Composite products.
2. Faster densification process (2-3 mm/hr) for realization of Carbon-Carbon Composite products.
3. Less parametric sensitive making the process robust and reliable.
4. Flexibility for realization of 2D, 2.5D & 4D C-C composite based products.

5. Realisation of Carbon-Carbon Composite products through a single process cycle.
6. Closed loop circulation of precursor thereby minimizing pollution aspects.

## Applications

Carbon-Carbon Products realized through Film Boiling CVI process can have wide spectrum of applications, considering high thermal shock resistance, capability of retaining mechanical strength at elevated temperatures and other characteristics of the material.

## Technology transfer from ISRO

ISRO is willing to offer the knowhow of this technology to suitable entrepreneurs/industries in India. Capable manufacturing industries interested in acquiring this knowhow may write with details of their present activities, requirements and plans for implementation, infrastructure and technical expertise available with them, their own market assessment, if any, and plans for diversification to the address given below.

NewSpace India Limited (NSIL)

Email: [contact-nsil@isro.gov.in](mailto:contact-nsil@isro.gov.in)

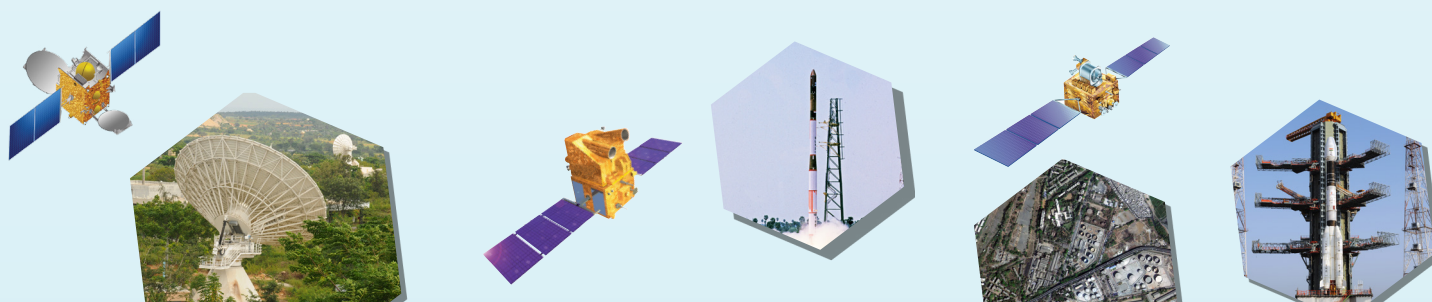

# Pulse Hard Anodization Process

Hard anodizing process produces a thick ceramic like coatings on Aluminum and its alloys. The micro hardness of the coating is more than 250 HV. These dense anodic coatings are usually thick by normal anodizing standards, and they are produced using special anodizing conditions. The thickness range is usually between 25 and 250  $\mu\text{m}$ . The hard anodic oxide coatings produced under special conditions have high hardness values and very good abrasion resistance compared to normal anodic coating.

## Features

- Pulse hard anodizing process is carried out at +10°C compared to conventional hard anodizing process, which is carried out at -5°C, thus saving a considerable cooling load.
- The burning and powdering problems associated with conventional hard anodizing process are eliminated

## Applications

- Hard anodic oxide coatings find application in the engineering industry for components where

abrasion resistance is the required primary characteristic of the coating. For Ex:

- Automobile Industry ( Pistons, Cylinders, Hydraulic gears)
- Aerospace Industries ( Variety of components like sliding / rotating mechanisms with solid lubricants, Thermal barrier coating, Thermal control coating etc.,)
- Chemical and flame resistant surfaces
- Cooking utensils
- Highly insulating (electrical) dielectric coating

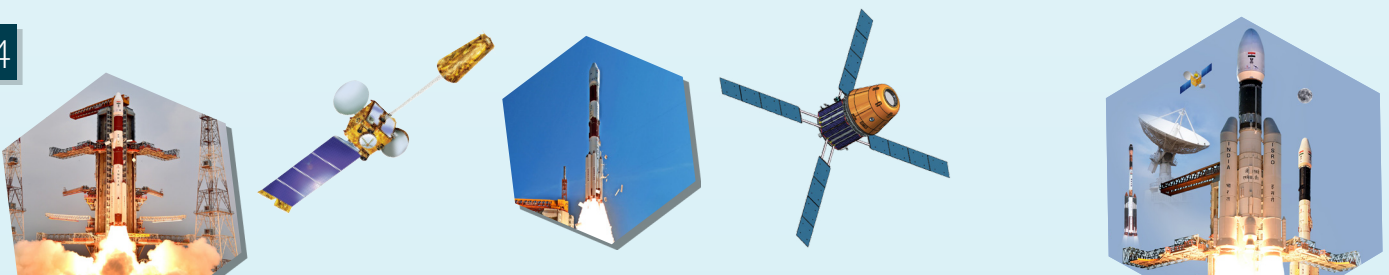

Processing Parameters	Conventional Hard Anodizing	Pulse Hard Anodizing	Advantages
Temperature (°C)	-5 ±2	10 ±2	<ul style="list-style-type: none"> <li>• Considerable saving in cooling load and cost.</li> <li>• Solution conductivity is better and permits higher current density processing.</li> </ul>
Current Density(A.ft-2)	35 ±5	45 ±5	<ul style="list-style-type: none"> <li>• Faster, better and harder coating</li> </ul>
Voltage (V)	24 -90	16 - 32	<ul style="list-style-type: none"> <li>• Heating at the interface of Component &amp; electrolyte is eliminated.</li> <li>• Burning problem is eliminated</li> </ul>
Time (min)	80 -120	40-60	<ul style="list-style-type: none"> <li>• The time taken to build up a thickness of 50-70 microns is halved.</li> <li>• Results in harder coating without powdering.</li> </ul>
Properties of the Coating			
Thickness (micron )	60±10		
Microhardness (HV)	250-350	250 - 500	<ul style="list-style-type: none"> <li>• Better and harder coating</li> </ul>
Insulation value	30-2.5 GΩ	30-1.5 GΩ	<ul style="list-style-type: none"> <li>• comparable</li> </ul>
Coff. Of friction	0.3 to 0.5	0.3 to 0.4	<ul style="list-style-type: none"> <li>• Comparable</li> </ul>
Corrosion resistance (Rp in Ω .cm <sup>2</sup> )	18.7 X 10 <sup>6</sup>	11.1 X 10 <sup>6</sup>	<ul style="list-style-type: none"> <li>• Comparabl</li> </ul>

## Technology Transfer from ISRO

ISRO is willing to offer the knowhow of this technology to suitable entrepreneurs / industries in India. Capable manufacturing industries interested in acquiring this knowhow may write with details of their present activities, requirements and plans for implementation, infrastructure and technical expertise available with them, their own market assessment, if any, and plans for diversification to the address given below:

NewSpace India Limited (NSIL)

Email: [contact-nsil@isro.gov.in](mailto:contact-nsil@isro.gov.in)

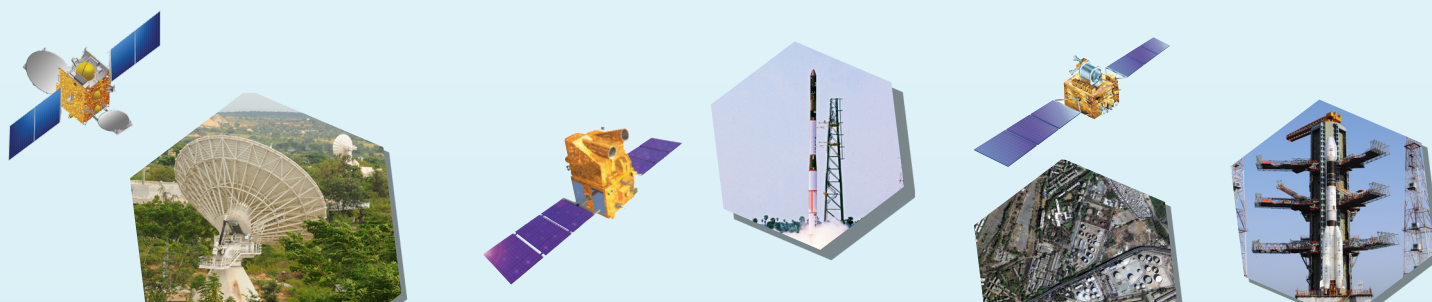

# Anodising on Titanium Alloys

U R Rao Satellite Centre (URSC) of Indian Space Research Organisation (ISRO) has developed anodizing process for Titanium and its alloys to impart corrosion resistance and multicolored aesthetic appearances used for colour coding applications.

## Salient Features

Anodising on Titanium alloys imparts a coloured aesthetic appearance to the base alloys. It is used as corrosion resistance coating as well as aesthetic architectural material in construction industries.

## Typical Properties / characteristics:

APPEARANCE	UNIFORM COATING
Thickness	$\cong 500 \text{ \AA}^\circ$
IR Emittance ( $\epsilon_{IR}$ )	$\cong 0.25 \pm 0.05$
Solar Absorptance ( $\alpha_s$ )	$\cong 0.70 \pm 0.05$

## Technology Transfer from ISRO

ISRO is willing to offer the knowhow of this technology to suitable entrepreneurs / industries in India. Capable manufacturing industries interested in acquiring this knowhow may write with details of their present activities, requirements and plans for implementation, infrastructure and technical expertise available with them, their own market assessment, if any, and plans for diversification to the address given below:

NewSpace India Limited (NSIL)

Email: [contact-nsil@isro.gov.in](mailto:contact-nsil@isro.gov.in)

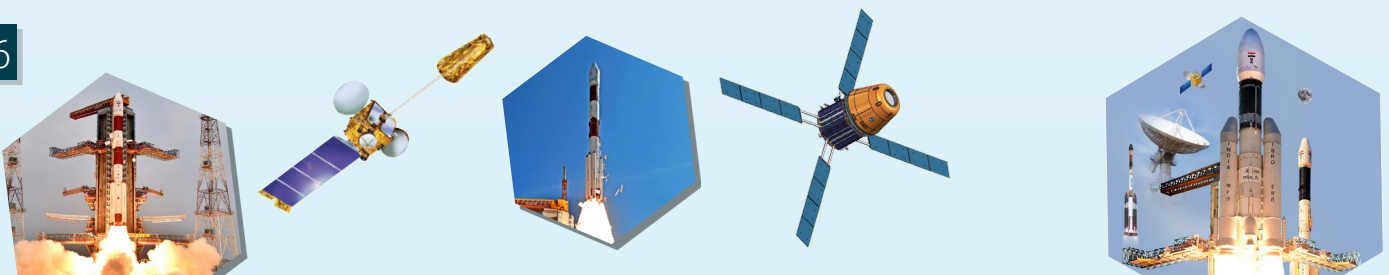

# Pulse Hard Anodising

UR Rao Satellite Centre (URSC) of Indian Space Research Organisation (ISRO) has developed pulse hard anodizing process on Aluminium alloys. The hard anodic oxide coatings produced under special conditions have high hardness values and very good abrasion resistance compared to normal anodic coating. Hard anodic oxide coatings find application in the engineering industry for components where abrasion resistance is the required primary characteristic of the coating.



## Salient Features

Pulse hard anodizing process is carried out at +10 °C compared to conventional hard anodizing process, which is carried out at -5 °C, thus saving a considerable cooling load. The burning and powdering problems associated with conventional hard anodizing process are eliminated.

## Major Specifications

Thickness (microns)	ASTM-B-244 Eddy Current Method	60±10 Micron
Microhardness (HV)	ASTM-E 384, Diamond Indenter	250 - 500
Insulation Value (Electrical)	10-100 V Range, DC	30 - 1.5 GΩ

## Technology Transfer from ISRO

ISRO is willing to offer the knowhow of this technology to suitable entrepreneurs / industries in India. Capable manufacturing industries interested in acquiring this knowhow may write with details of their present activities, requirements and plans for implementation, infrastructure and technical expertise available with them, their own market assessment, if any, and plans for diversification to the address given below:

NewSpace India Limited (NSIL)

Email: [contact-nsil@isro.gov.in](mailto:contact-nsil@isro.gov.in)

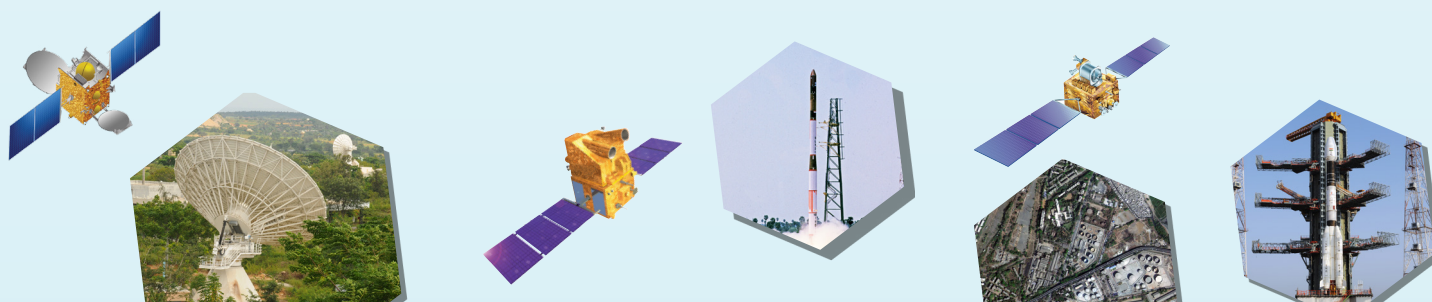

# Nanoparticle (Silver & Gold) coating on Aluminum

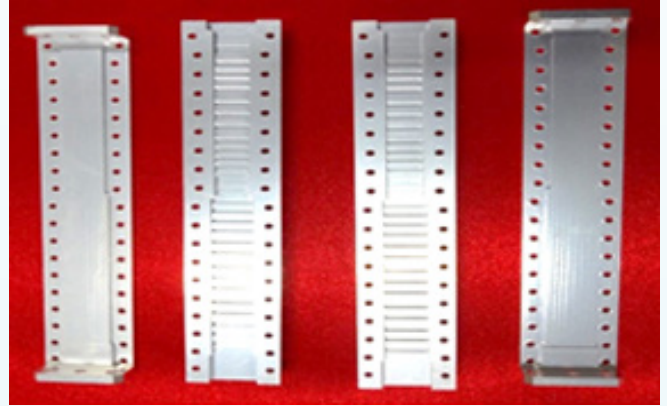
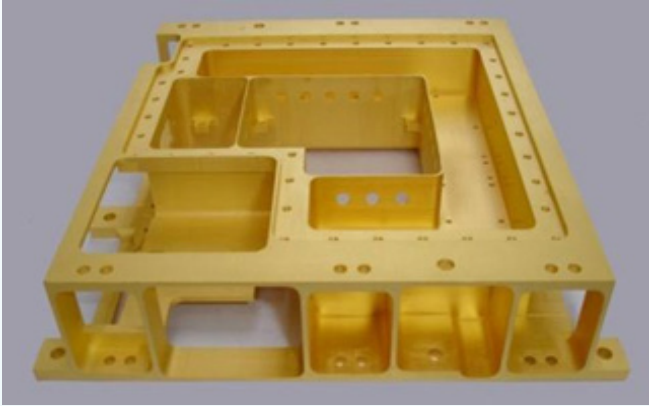

Space Applications Centre (SAC) has developed and qualified a robust Nanoparticle (Silver & Gold) coating on Aluminium 6061T6. The high electrical conductivity of gold, low contact resistance and good solderability combined with the consistency of these properties over wide range of environment conditions experienced by satellite makes gold plating the ideal choice for plating electronic hardware. Nano particle size is in the range of 25-50 nm. The nano silver plating on aluminum alloy components such as RF filters improves surface conductivity and hence reduces the insertion losses. The process is used for components like waveguides, adaptors, HRFs, filters etc. Silver plated waveguides are used in communication payloads of satellites. Nano Silver plating on Aluminum is optimized to give better RF performance as compared to traditional silver plating. Nano Silver coating provides high luster, electrical conductivity near to pure silver and is solderable. Indoor humid environment tarnish resistance is achieved by nano deposition.

## Applications area

- Engineering / Industrial
- To enhance the electrical conductivity of the surface

## Specifications:

Gold Nano Plating on Aluminum 6061T6	
Undercoat	Nickel-Phosphorous (Electroless Nickel)
Composition of undercoat	Nickel – Phosphorous (8-12%)
Undercoat thickness	10-12 $\mu$
Topcoat	Gold (Electroplating)
Type of Gold Plating	Acidic Gold Potassium Cyanide
Purity of Gold	99.99%
Thickness of Gold plating	2.0 $\pm$ 0.5 $\mu$ or 1.0 $\pm$ 0.2 $\mu$

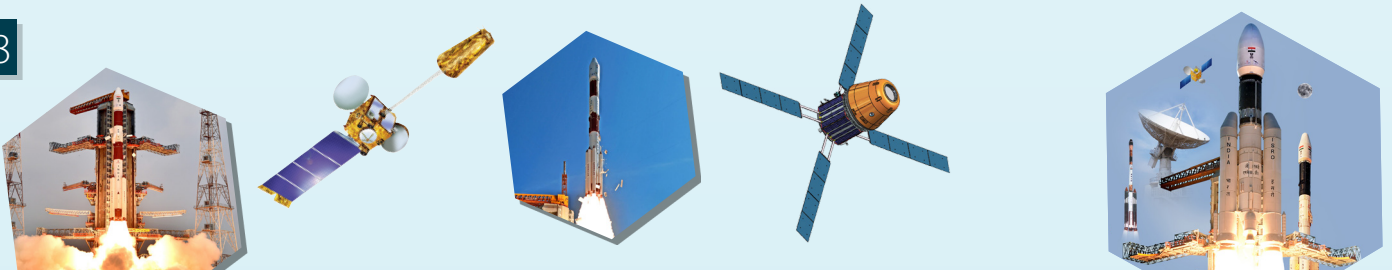



Silver Nano Plating on Aluminum 6061T6	
Undercoat	Nickel-Phosphorous (Electroless Nickel)
Composition of undercoat	Nickel – Phosphorous (8-12%)
Undercoat thickness	8-12 $\mu$
Topcoat	Silver (Electroplating)
Type of Silver Plating	Basic Silver Potassium Cyanide
Thickness of Silver plating	7.0 $\pm$ 2.0 $\mu$

## Salient Features

- Processed developed after undergoing intense qualification plans and tests to withstand harsh space-like conditions.
- Highly stable cyanide based chemistry.
- Easy to control and maintain.
- Optimized for uniform and dense thickness with liberal process parameters range.
- Undercoat of electroless nickel for better corrosion protection of aluminum.
- Silver nano particle coating resistant to indoor humid environment tarnish effects tested as per ASTM B809.

## Technology Transfer from ISRO

ISRO is willing to offer the knowhow of this technology to suitable entrepreneurs / industries in India. Capable manufacturing industries interested in acquiring this knowhow may write with details of their present activities, requirements and plans for implementation, infrastructure and technical expertise available with them, their own market assessment, if any, and plans for diversification to the address given below:

NewSpace India Limited (NSIL)

Email: [contact-nsil@isro.gov.in](mailto:contact-nsil@isro.gov.in)

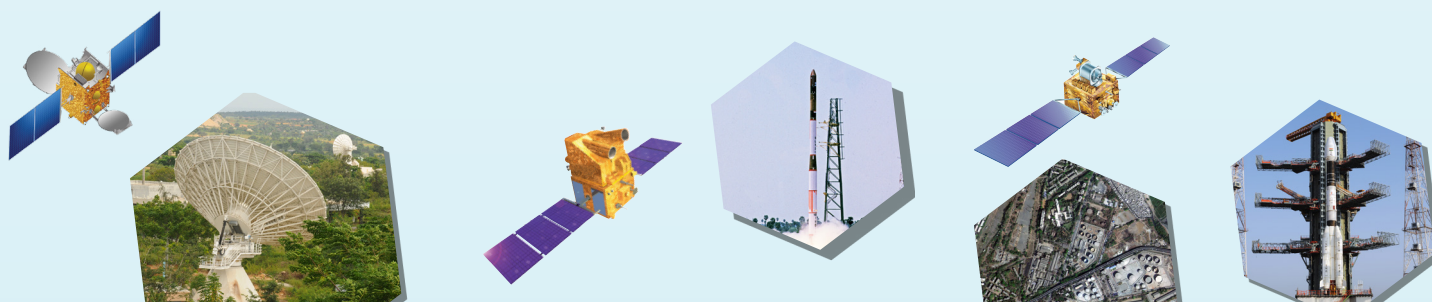

# Nano-Structured Metal Deposition by Electroplating Method for PCB required for Space Application

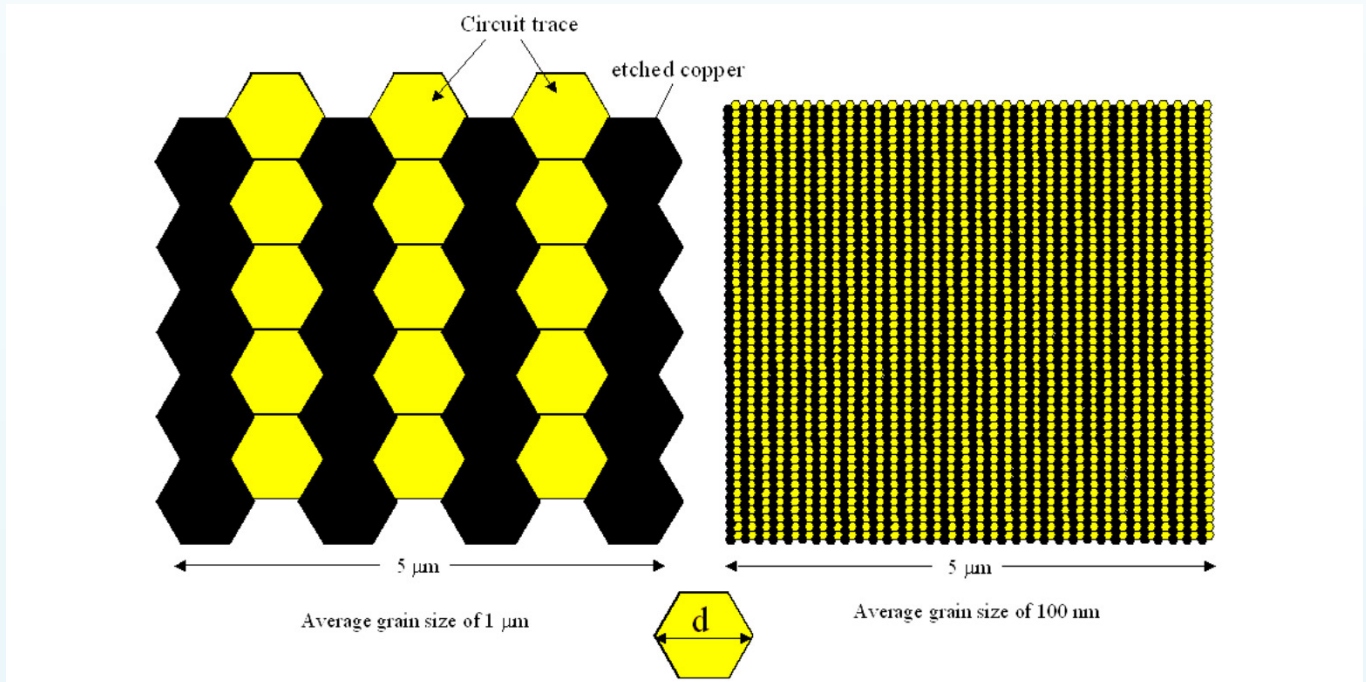

Space Applications Centre (SAC) has developed Nano-Structured Metal Deposition by electroplating method for PCB. This technology ensures the deposition of <100 nm copper and gold metal deposition by electroplating method for RF/Microwave PCB circuits fabrication. Nano crystalline and ultra-fine grain deposited copper by this technology can potentially offer improved reliability and functionality to the PWB. Secondly Nanocrystalline deposition significantly contribute for the isotropic etching characteristics of copper during the lithographic etching process, hence wiring density can be increased through grain size reduction. Nano soft gold plating deposit provides an extremely pure deposit of gold and non-porous coating.

## Applications area

- PTH Gold plated PCBs for RF/Microwave applications.
- MLBs with high aspect ratio boards.

## Salient features

With this technology it is possible to etch 100-micron track width and spacing. Moreover, fabrication process passes through all qualification tests including following environmental and functional tests.

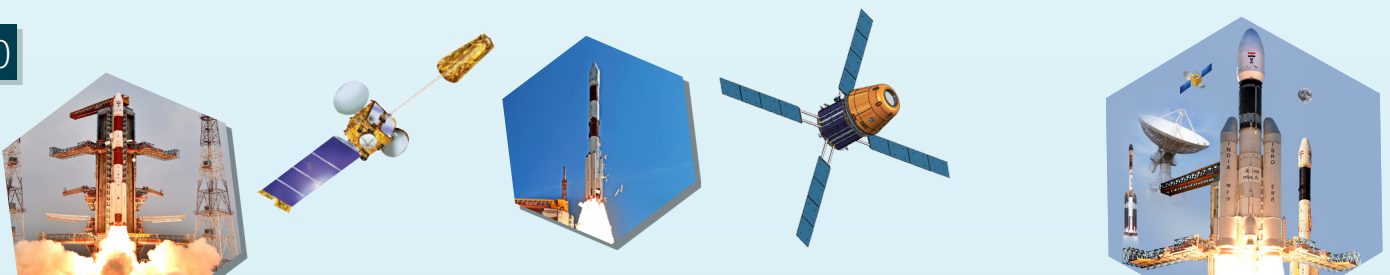

Salient features	
Hot Storage	125 °C – 168 Hours
Thermal Cycling	- 65 °C – 10 min., +125 °C – 10 min., No. of Cycles: 200 (100 + 100)
Humidity	- 40°C ± 2°C 90 – 95 % RH for 21 days
1 mil Wire, 5/10/20mil Ribbon Bonding (5 bonds of each) using parallel gap method	

## Broad Specifications

- Copper nano deposition < 100 nm
- Gold nano deposition < 100 nm

## Process Schematic diagram

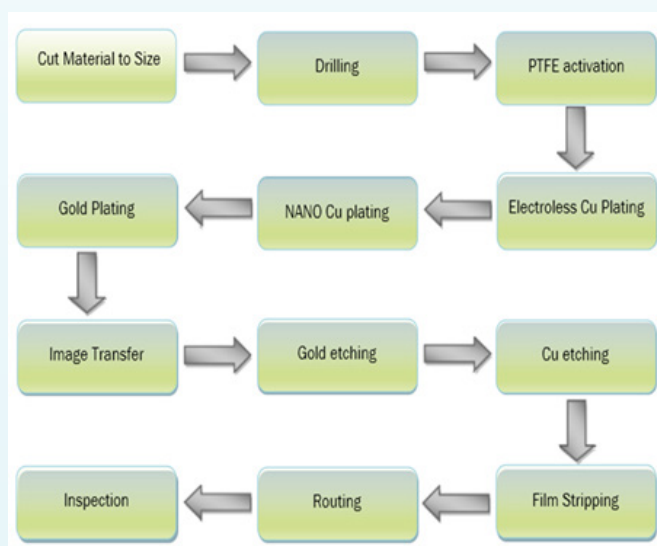

## Technology Transfer from ISRO

ISRO is willing to offer the knowhow of this technology to suitable entrepreneurs / industries in India. Capable manufacturing industries interested in acquiring this knowhow may write with details of their present activities, requirements and plans for implementation, infrastructure and technical expertise available with them, their own market assessment, if any, and plans for diversification to the address given below:

NewSpace India Limited (NSIL)

Email: [contact-nsil@isro.gov.in](mailto:contact-nsil@isro.gov.in)

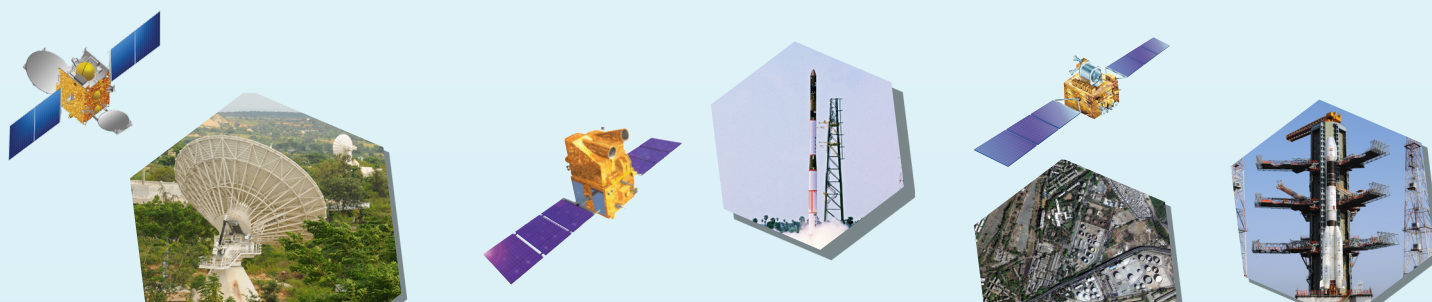

# Electroless Nickel Electroless Palladium Immersion Gold (ENEPIG) Process for Printed Circuit Boards

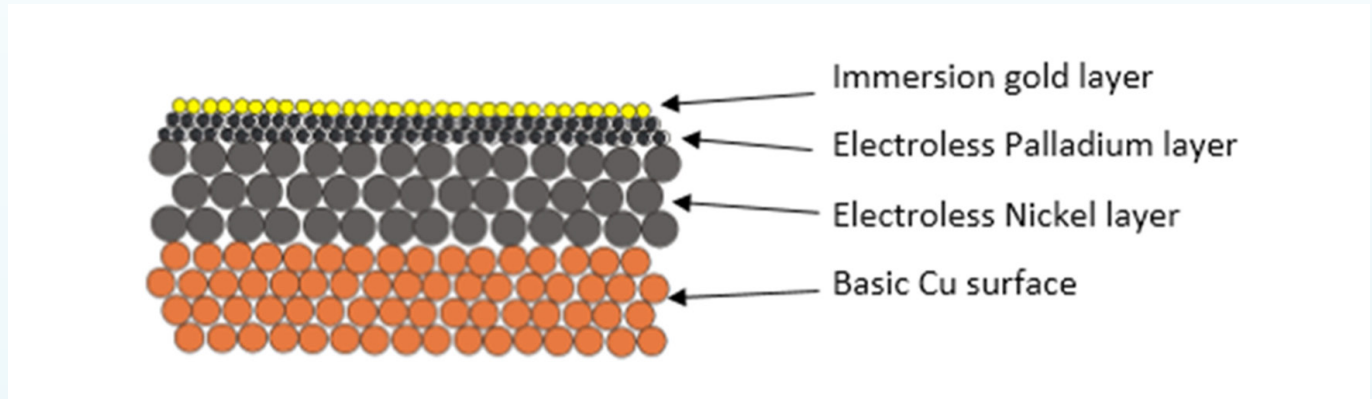

*Electroless Nickel Electroless Palladium Immersion Gold (ENEPIG) surface finish*

Space Applications Centre (SAC) has developed Electroless Nickel Electroless Palladium Immersion Gold (ENEPIG) surface finish is most suitable surface finish. Here palladium is added between electroless nickel and immersion gold as shown in fig. Palladium layer plays a role in stopping immersion gold technology from corroding nickel layer. As a result, ENEPIG is capable of defeating the defect of black pad held by ENIG. Moreover, ENEPIG provides planner solderable finish, Al and gold wire bondable, nickel strengthen the PTH, Nickel barrier prevent the copper dissolution during thermal exposure, it has good shelf life and does not tarnish. This process overcomes some of the limitations of Hot Air Solder levelling and electrolytic gold types of surface finish, being used for digital/analog and RF/Microwave applications

## Applications area

- PPTH Gold plated PCBs for RF/Microwave applications.
- MLBs with high aspect ratio boards.

## Salient features

Optimised fabrication process is passes through all qualification tests including following environmental and functional tests.

- Hot Storage: 125 °C – 168 Hours
- Thermal Cycling: - 65 °C – 10 min., +125 °C – 10 min., No. of Cycles: 200 (100 + 100)
- Humidity: - 40°C ± 2°C 90 – 95 % RH for 21 days
- 1mil Wire, 5/10/20mil Ribbon Bonding (5 bonds of each) using parallel gap method

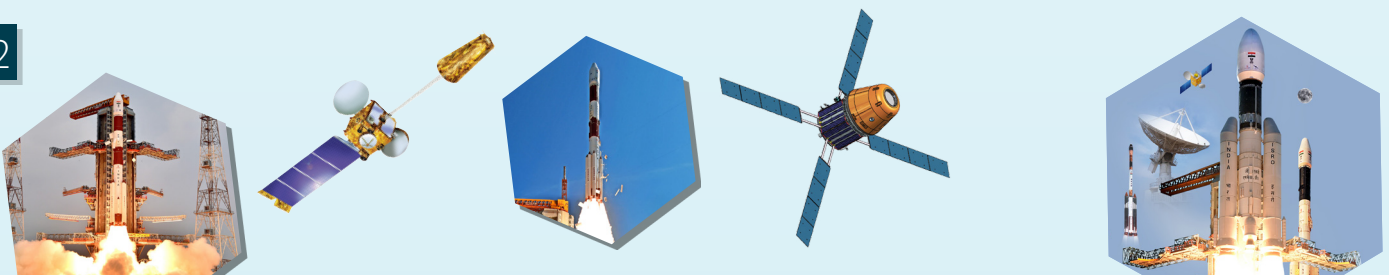

## Broad Specifications

- Immersion Gold layer thickness: 0.07 to 0.15  $\mu\text{m}$
- Electroless Pd layer thickness: 0.1 to 0.30
- Electroless Ni layer thickness: 3 to 5  $\mu\text{m}$

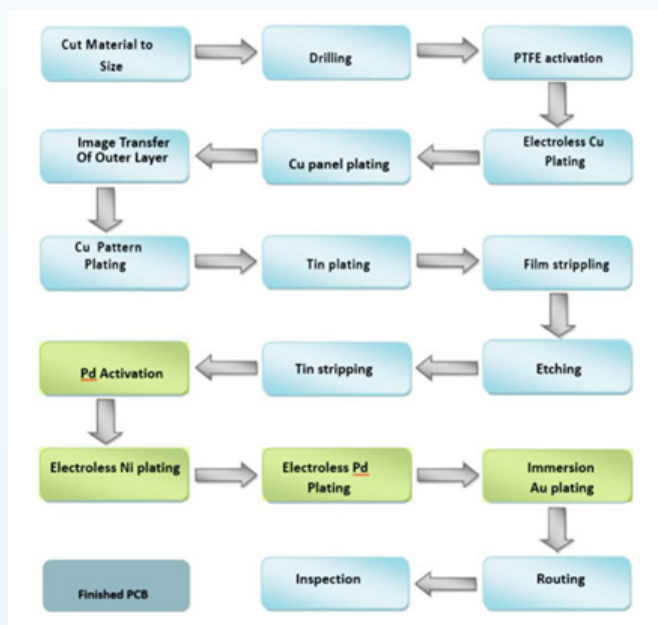

## Technology Transfer from ISRO

ISRO is willing to offer the knowhow of this technology to suitable entrepreneurs / industries in India. Capable manufacturing industries interested in acquiring this knowhow may write with details of their present activities, requirements and plans for implementation, infrastructure and technical expertise available with them, their own market assessment, if any, and plans for diversification to the address given below:

NewSpace India Limited (NSIL)

Email: [contact-nsil@isro.gov.in](mailto:contact-nsil@isro.gov.in)

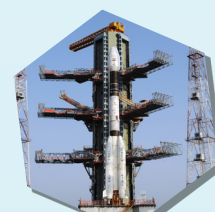
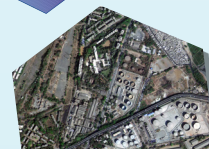
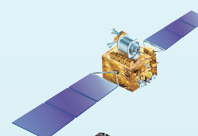
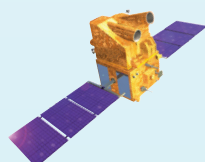
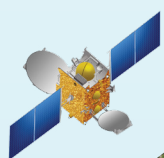

# Gold Plated PTH / NON PTH PCBS

on PTFE Based Substrates For RF/ MM Wave Applications for Space and Ground use

## Product specifications

- Minimum hole dia 0.3 mm for serial no. 1,2, and 5
- Minimum hole dia 0.5 mm for serial no. 3 and 4
- Surface activation of PTFE based laminates.
- Soft gold plating
- Gold Overhang  $\leq$  10 micron
- Track width and spacing 130 micron
- Slot dimension 0.8 mm to 1.5 mm

## Salient Features

Laminate types: Process is capable to fabricate space qualified PCBs on following types of substrates, with thickness varies from 10 mil to 25 mil.

1. RT Duroid 6002 ½ / ½ Cu
2. RT Duroid 6010 ½ / ½ Cu
3. RT Duroid 6002 ½ / 1mm Cu
4. RT Duroid 6010 ½ / 1 mm Cu
5. TMM10i

## Approximate Work Load Per Year

- 800 to 1000 PCBs for on-board
- 1000 to 1200 PCBs for ground applications

## Technology Transfer from ISRO

ISRO is willing to offer the knowhow of this technology to suitable entrepreneurs / industries in India. Capable manufacturing industries interested in acquiring this knowhow may write with details of their present activities, requirements and plans for implementation, infrastructure and technical expertise available with them, their own market assessment, if any, and plans for diversification to the address given below:

NewSpace India Limited (NSIL)

Email: [contact-nsil@isro.gov.in](mailto:contact-nsil@isro.gov.in)

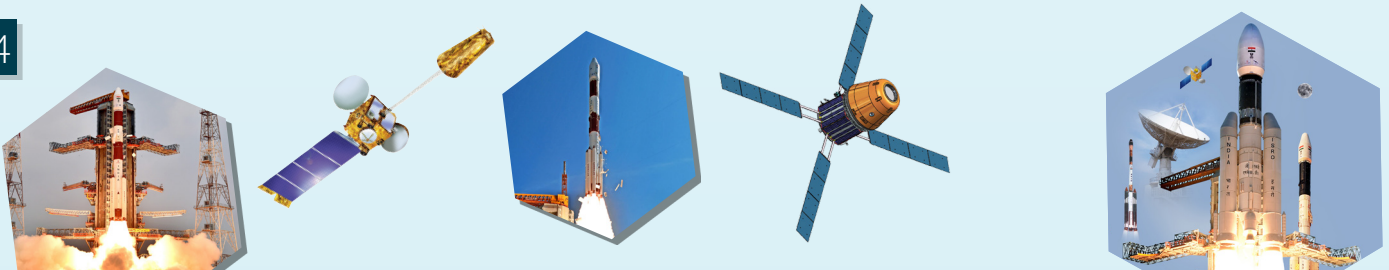

## Precision Tapping Attachment

Space Applications Centre of Indian Space Research Organization at Ahmedabad has developed a Precision Tapping Attachment which is much useful for precision tapping in mechanical packages. This attachment is useful for tapping of highly precise M1.2 screws and onwards with accuracy.

### Salient Features

1. Useful for highly precise M1.2 screws and onwards with accuracy.
2. To ensure for perfect and precise tapping with perpendicularity.
3. Ensuring tapping up to proper depth.
4. No jamming or breaking of tapping tool.
5. Even unskilled worker can also use it.
6. Increasing in productivity.

### Technical Specifications

Tapping Capacity	: Starting form highly precise M1.2
Overall Size	: 345 mm x 300mm x 330 mm height
Swiveling of arm	: 360°
Vertical Adjustment	: Easily possible up to 300 mm
Horizontal Adjustment	: In range of 50 mm, Maximum Distance 215 mm
Tapping Operation	: Manually
Overall Weight	: 9 kg
Tools	: Standard tools can be used
Extension	: Extendable for Helicoil insertion and semi-automation for vertical feed and lubrication

### Technology Transfer from ISRO

ISRO is willing to offer the knowhow of this technology to suitable entrepreneurs / industries in India. Capable manufacturing industries interested in acquiring this knowhow may write with details of their present activities, requirements and plans for implementation, infrastructure and technical expertise available with them, their own market assessment, if any, and plans for diversification to the address given below:

NewSpace India Limited (NSIL)

Email: [contact-nsil@isro.gov.in](mailto:contact-nsil@isro.gov.in)

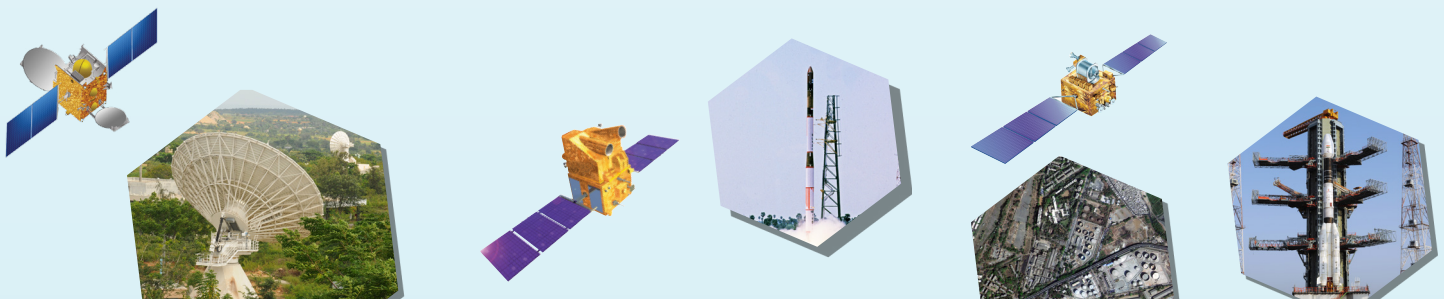

# Vibration Management Solutions

Manages motion-Minimizes vibration, shock and noise

- Developed by Space Applications Centre, ISRO, Ahmedabad.
- Delicate electronic and optical systems which are vulnerable to vibration and shock can be protected from these.
- This Vibration Management Solutions (SVMS) solves vibration and shock difficulties during transportation on ground and space.
- SVMS systems are based on wire rope mounts that provide inherent damping by virtue of relative motion between wire strands.
- Wire rope isolators usually can accommodate large deflections without the danger of bottoming and plastically deforming, hence offers a wide range of isolation to a variety of applications.

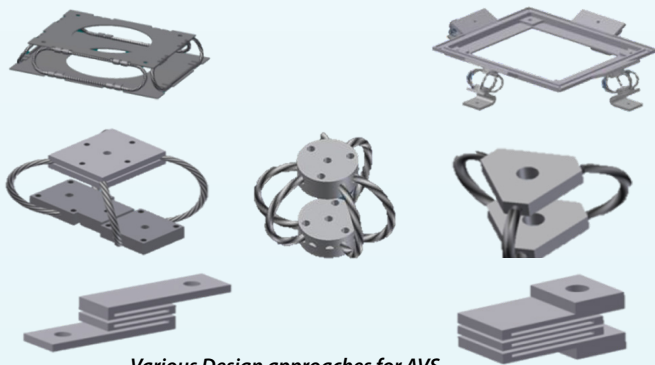

Various Design approaches for AVS

## SVMS Types:

- SVMS Quad-Fed
- SVMS Tri-Fed
- SVMS Hex-Fed
- SVMS Platform

## Salient features

- All metal construction
- High inherent damping
- Wide Temperature Range – 100-200°C
- Maintenance Free
- Corrosion Resistant
- Multidofs

## Potential Application Areas

- Space Missions Payload Systems and instruments
- Delicate systems Suspension in planetary Landers
- Air / Road / Sea Transportation
- Foundation of Equipment
- Chemical Processing Equipment
- Seismic isolation

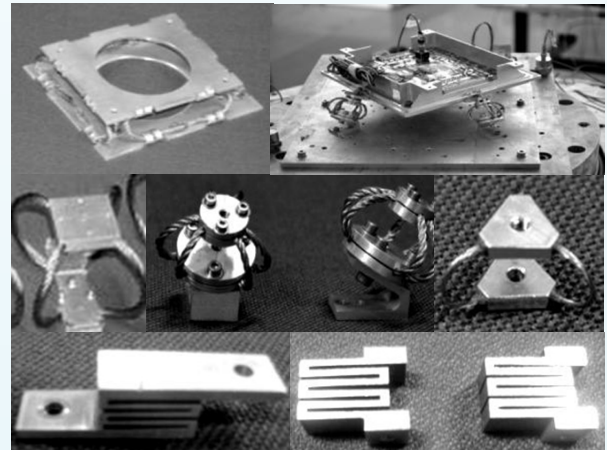

Realized AVS approaches

## TECHNICAL SPECIFICATIONS

Type	Supported mass(Gm)	frequency range(hz)
SVMS Quad-Fed	400-3000	5-2000*
SVMS Tri-Fed	<18	
SVMS Hex-Fed	<65	20-2000
SVMS Platform	<240	

NewSpace India Limited (NSIL)

Email: [contact-nsil@isro.gov.in](mailto:contact-nsil@isro.gov.in)

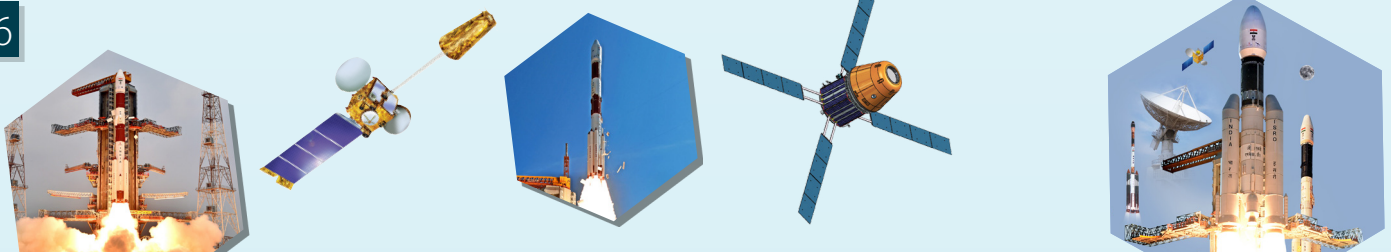



# Fabrication of Waveguide Runs

Space Applications Centre (SAC) of Indian Space Research Organisation (ISRO) has developed an Innovative Process technology to fabricate Waveguide run from Thin Walled Rectangular Tubes having various cross sectional dimensions.

These waveguide runs are of various shapes & different lengths and are being used for making total waveguide plumbing line, by assembling the said waveguide runs through flanges welded at each end. The different shapes are being made by variety of bends & twists generated through forming process by working on straight tubes.

## Technical Specification

### Raw Material Details

<b>Form</b>	<b>Rectangular rolled tubes</b>
Material	Al. Alloy 6061-T6
Internal Surface Finish	1.6 Micron

### Type of Cross Section & Joining of End Flanges Raw Material Details

Waveguide	Internal imension (L x B) in mm	Wall Thickness in mm
WR-75	19.05 x 9.525	0.635
WR-51	12.95 x 6.47	0.635
WR-28	7.11 x 3.55	0.635

Waveguide	Bends	Bend Angles (Degrees)	E Plane mean Bend Radius (mm)	H Plane mean Bend Radius (mm)	Twist Angles (Degree)
WR-75	E-Plane, H Plane	0 to 180	30	35	0 to 90
WR-51	E-Plane, H Plane	0 to 180	20	25	0 to 90
WR-28	E-Plane, H Plane	0 to 180	20	20	0 to 90

Process of Joining of flanges with waveguide	Space Qualified Tungsten Inert Gas(TIG) Welding
Material	Al. Alloy 6061-T6
Internal Surface Finish	1.6 Micron
Thickness	1.2 mm to 0.635 mm
Quality*	RF Leak Proof

## Applications

- Ground as well as Airborne Radar
- Transmission & Reception in range of Microwave frequencies
- Satellite based Communication System
- In the devices of Navigation Aids
- High power testing of Microwave system

## Technology Transfer from ISRO

ISRO is willing to offer the knowhow of this technology to suitable entrepreneurs / industries in India. Capable manufacturing industries interested in acquiring this knowhow may write with details of their present activities, requirements and plans for implementation, infrastructure and technical expertise available with them, their own market assessment, if any, and plans for diversification to the address given below:

NewSpace India Limited (NSIL)

Email: [contact-nsil@isro.gov.in](mailto:contact-nsil@isro.gov.in)

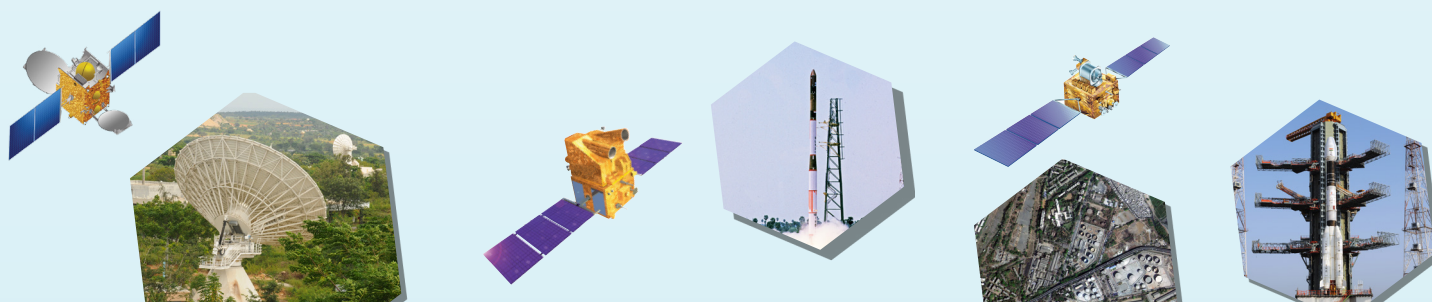

# Sit on Umbilicals for remote Fluid servicing of Launch

Umbilicals are extensively used in the fields of aviation, space technology as well as automobiles. Indian Space Research Organisation (ISRO) at its Liquid Propulsion Systems Centre has developed a compact and reliable sit on Umbilical which can be used for remote fluid servicing of Launch Vehicles.

## Principle of operation

This innovation though is developed for a specified requirement (servicing the lower stage of launch vehicle) can be extended to various other applications. This system has a flight segment (part of vehicle) which sits over the ground segment (assembled to launch pedestal). The flight segment gets lifted off along with vehicle upward movement.

The system has got a pack of Belleville disc springs to take up longitudinal deflections and a twin spherical ball mechanism to transfer disc spring load to ground segment and also accommodate vehicle sway. Moreover, the system employs push open type check valves for fluid transfer in mated condition.



## Specification

- Accommodate vehicle sway of +10mm
- Accommodate vehicle longitudinal deflection of 10mm in downward direction
- The ground segment & flight segment has to separate within 20mm of vehicle lift off.
- Automatic sealing devices should automatically close after vehicle lift off ensuring leak tightness

both in mated and separated condition.

- External leak of SOU in mated condition  $\leq 1 \times 10^{-3}$  sccm/sec of GN2 at Room

## Temperature

- Envelope of SOU should be minimum.
- Flight segment to have minimum aerodynamic load during flight.

## Advantages and salient features

- Minimum assembly and test time required at launch pad.
- Provides completed testability & serviceability at launch pad.
- Simple concept of self sealing connectors
- Easy fabrication and testing
- Compact design
- Design allows easy de-mating when flight segment gets lifted off along with vehicle upward movement. No complex locking and separating mechanism.

## Applications

- Servicing of military and commercial aircrafts
- Remote fluid servicing of missiles
- Oil rigging operations
- Automobile industry
- Chemicals and fertilizer industry handling toxic chemicals
- Locomotives
- Commercial gas (LPG) filling center

NewSpace India Limited (NSIL)

Email: [contact-nsil@isro.gov.in](mailto:contact-nsil@isro.gov.in)

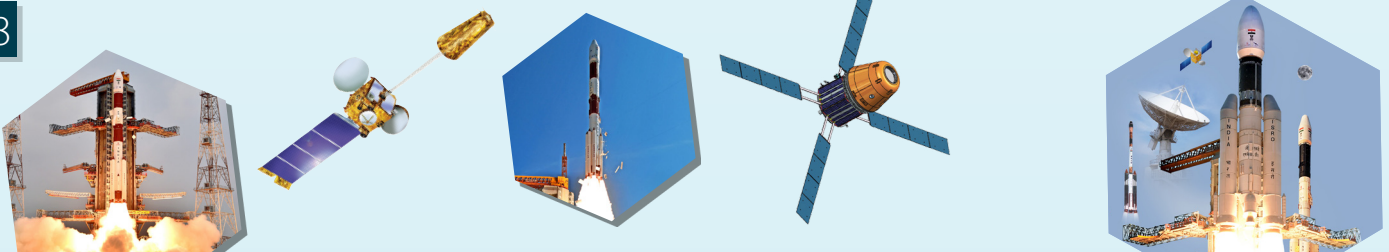

# Tool For Connector Pin & Teflon Trimming

## Tool Features

- Teflon & pin trimming with  $\pm 50 \mu\text{m}$  accuracy.
- No cut marks (Nicks) on pins
- Zero defect process output
- High throughput
- Motorized & simple tool, hence,
- person independent process

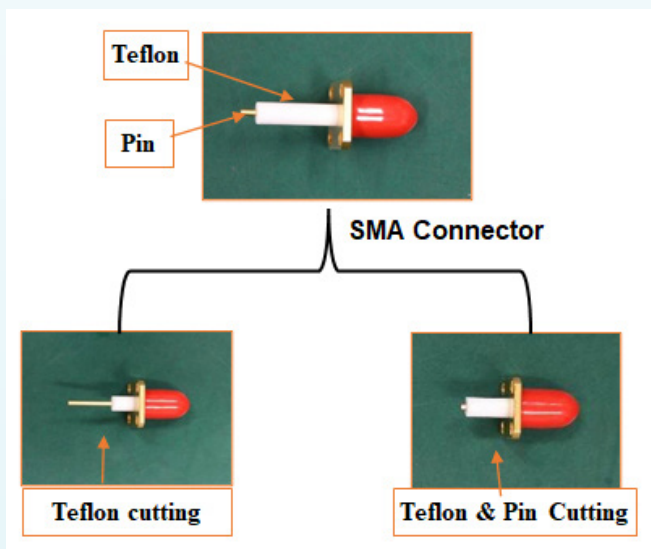

## Application Area

- Patch Antenna, waveguide adaptor,
- Large numbers required in SAC.
- Probable co.: Astra AMPL
- Escc qualified fm grade

## Technology Transfer from ISRO

ISRO is willing to offer the knowhow of this technology to suitable entrepreneurs / industries in India. Capable manufacturing industries interested in acquiring this knowhow may write with details of their present activities, requirements and plans for implementation, infrastructure and technical expertise available with them, their own market assessment, if any, and plans for diversification to the address given below:

NewSpace India Limited (NSIL)

Email: [contact-nsil@isro.gov.in](mailto:contact-nsil@isro.gov.in)

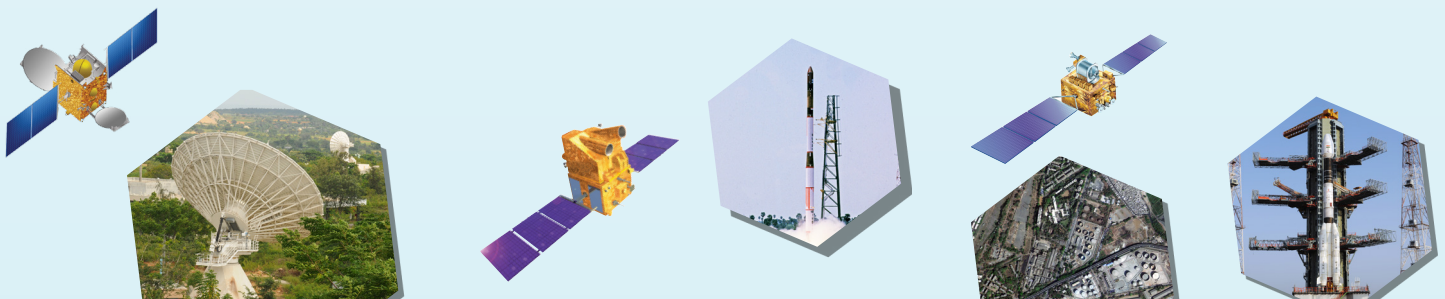

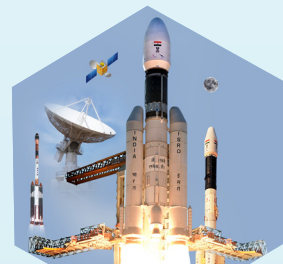
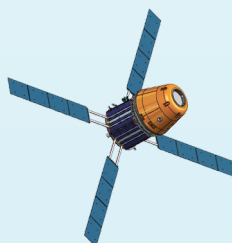
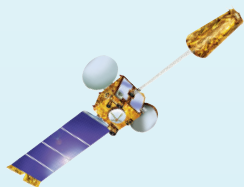

## SAC Video Imaging System (SVIS)

Space Applications Centre of Indian Space Research Organisation has designed and developed a state of the art Video Imaging System called as "SVIS". It is a space grade certified system that provides high resolution color images with higher frame rates.

SVIS consists of a CMOS based sensor, Camera, Digital card, DC-DC card along with Solid State Recorder. Solid State Recorder (SSR) is NAND flash based which is used to process high resolution image data transfer with higher frame rates. At present, this system is being used in the launch vehicles for capturing high resolution images with higher frame rates as and when required.

### Salient Features

S/N	Parameters	Description
1.	Detector	1600 x 1200 (2M) CMOS sensor
2.	FOV & depth of field	50 deg; 600 mm minimum
3.	Frame Size/ resolution	1600 x 1200 (Maximum)
4.	Frame Size	~30 Mb (Before compression) ~1.5 Mb (After compression)
5.	On-board Storage capacity	~ 2 – 4 Gb
6.	Output data rate	Commensurate with DROPS Protocol (400-500 Kbps)
7.	Power	< 7 W
8.	Frame Rate	

### Applications

- High resolution image data capture
- High frame rate data capture

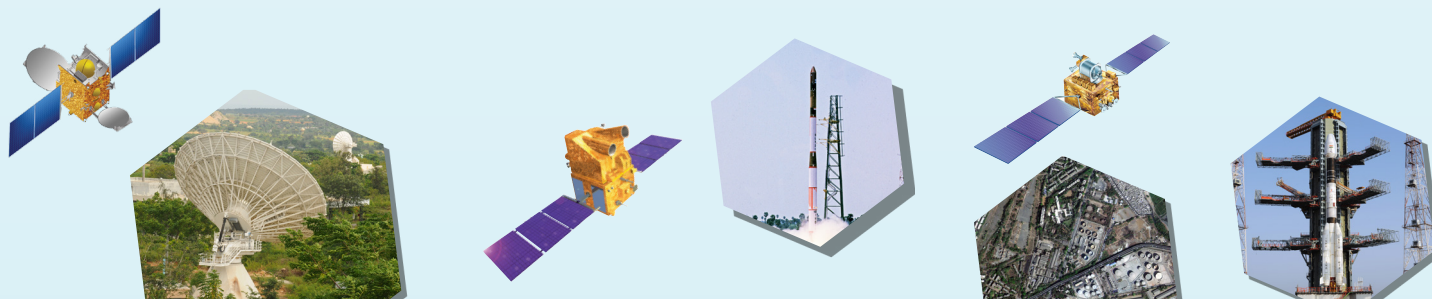

Image capture by onboard camera during payload separation

### Technology Transfer from ISRO

ISRO is willing to offer the knowhow of this technology to suitable entrepreneurs / industries in India. Capable manufacturing industries interested in acquiring this knowhow may write with details of their present activities, requirements and plans for implementation, infrastructure and technical expertise available with them, their own market assessment, if any, and plans for diversification to the address given below:

NewSpace India Limited (NSIL)  
Email: [contact-nsil@isro.gov.in](mailto:contact-nsil@isro.gov.in)



# Optical Imaging System

## An Advanced Technology from ISRO

- Useful under twilight and mid-day lighting conditions
- Sampling Resolution: 2cm at 5000 m
- FOV:  $0.46^\circ \times 0.46^\circ$
- 200 mm RC Telescope
- Operating Wavelength range: Vis-VNIR
- Frame rate: 30 Hz (Rolling shutter)
- Programmable Exposure period
- Includes Focusing Mechanism
- Camera Head control, video data acquisition, NUC correction, and image visualization s/w with intra-scene dynamic range adjustment for 2kx2k Si based focal plane array
- Sturdy Mechanical Structure
- Weight: <10 kg

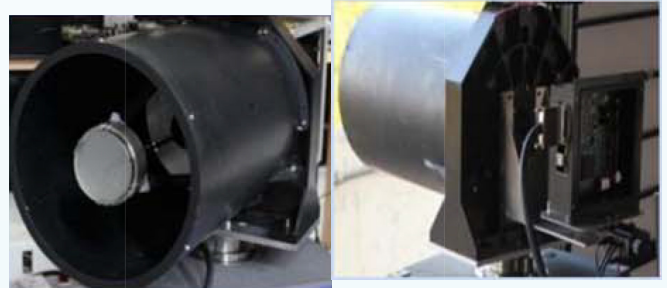

Avg: 5000 photons

Avg: 50 photons

### Potential Applications

- Imaging during day time and twilight condition
- Scientific Studies, Astronomy
- Applications requiring high intra-scene dynamic range up to 80 dB



Avg: 5000 photons

Avg: 15 photons

(Locally processed with digital filter)

### Possible Customizations

- Multi-band (with frequency selective beam splitter or filter wheel), including Infrared spectrum, target imaging using suitable focal plane array
- Frame rate enhancement up to 100 frames/s
- Temperature compensated automatic focus adjustment
- RGB Color imagery with incorporation of color data processing pipe
- Nighttime imaging with external illuminator

NewSpace India Limited (NSIL)

Email: [contact-nsil@isro.gov.in](mailto:contact-nsil@isro.gov.in)

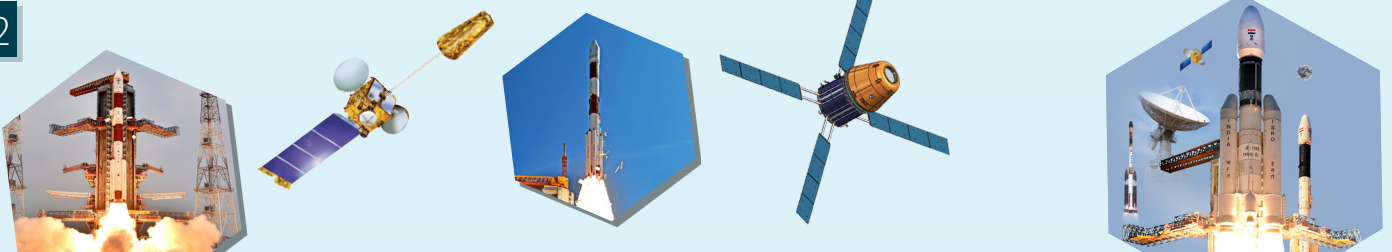

## Film Adhesives EFA 1753 and EFA-1752 (Structural adhesives for honeycomb sandwich fabrication)

Vikram Sarabhai Space Centre of Indian Space Research Organization has developed an epoxy film adhesive; EFA-1753 (300 GSM) and EFA-1752 (200 GSM) (in the form of continuous film) that cures at elevated temperature 175 °C for 1 h and they possess good adhesive strength and filleting properties. Light-weight honeycomb sandwich structures are extensively made using epoxy film adhesives with precisely controlled glue line thickness. Film adhesive can also be used by shipping and boat manufacturing industries also, for fabrication of sandwich structures and other composite assemblies.

### Salient Features

- One-component, heat curable, toughened, high strength polymeric film adhesive.
- Heat curable (175°C for 1 h).
- Ensures filleting during curing, leading to very high bond strength in honeycomb sandwich.
- Space qualified.

Properties	Values
Areal density, GSM [Two types]	300±20 (EFA 1753) and 200±20 (EFA 1752)
Lap shear strength at 25°C (Al/Al), MPa	≥ 25
LSS at 130°C (Al/Al), MPa	≥ 12
LSS at -196°C(Al/Al), MPa	≥ 25
Honeycomb Flat wise tensile strength at 25°C, MPa	≥ 4
TML, %	≤ 1.0
CVCM, %	≤ 0.1

### Technology transfer from ISRO

ISRO is willing to offer the knowhow of this technology to suitable entrepreneurs/industries in India. Capable manufacturing industries interested in acquiring this knowhow may write with details of their present activities, requirements and plans for implementation, infrastructure and technical expertise available with them, their own market assessment, if any, and plans for diversification to the address given below.

NewSpace India Limited (NSIL)

Email: [contact-nsil@isro.gov.in](mailto:contact-nsil@isro.gov.in)

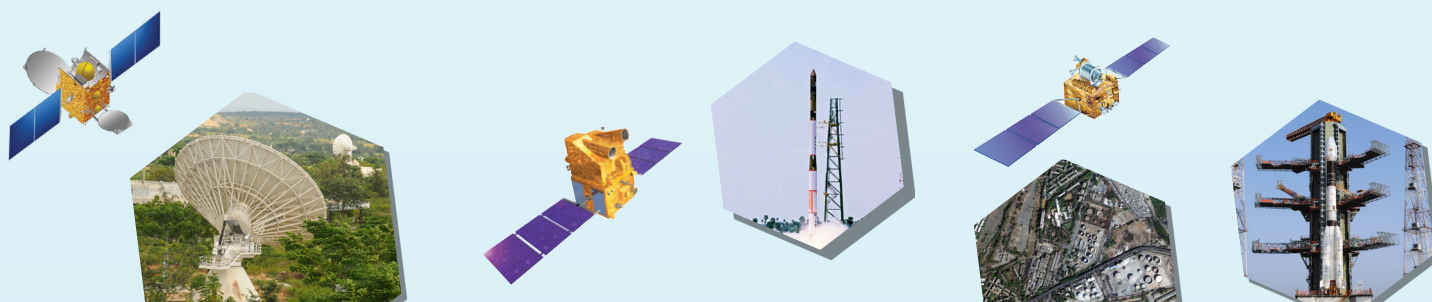

## EPG 2601 [M]

ADBOND EPG 2601M is formulated for bonding of honeycomb structures and capable of working under harsh space environments such as thermo-vacuum, thermal cycling, radiation etc. The main feature of this material is that it is thermally conducting and can retain its property at very low temperatures.

ADBOND EPG 2601M is a two part chemically reactive epoxy structural adhesive system consists of polyether modified epoxide resin, filler, rheological additive and colorant in the resin part, curing agent and accelerator in the hardener part. Cure is achieved by mixing the hardener part with resin part packed separately.

Some of the specialties of this material are minimum cure shrinkage combined with excellent adhesion, superior strength & toughness and low out gassing  
Typical properties/ characteristics

1	Color & consistency	Part A: Black, viscous resin, Part B: Brownish yellow
2	Viscosity (ps)	1000 to 4000
3	Sp. Gravity	1.65
4	Hardness (Shore D)	≥70
5	Lap shear strength (ksc) on Alumina at RT	120
6	Thermal conductivity (cal/cm/C/s)	8* 10 <sup>-4</sup>

7	Coefft. of thermal expansion (/ oC)	3.5 x 10 <sup>-5</sup> – 10 x 10 <sup>-5</sup>
7	Volume Resistivity (ohm- cm)	6* 10 <sup>12</sup>
8	Out gassing	
9	- TML (%)	1
10	- CVCM (%)	0.05
11	Service temperature	93 K to 373 K

### Technology transfer from ISRO

ISRO is willing to offer the knowhow of this technology to suitable entrepreneurs / industries in India. Capable manufacturing industries interested in acquiring this knowhow may write with details of their present activities, requirements and plans for implementation, infrastructure and technical expertise available with them, their own market assessment, if any, and plans for diversification to the address given below:

NewSpace India Limited (NSIL)  
Email: [contact-nsil@isro.gov.in](mailto:contact-nsil@isro.gov.in)

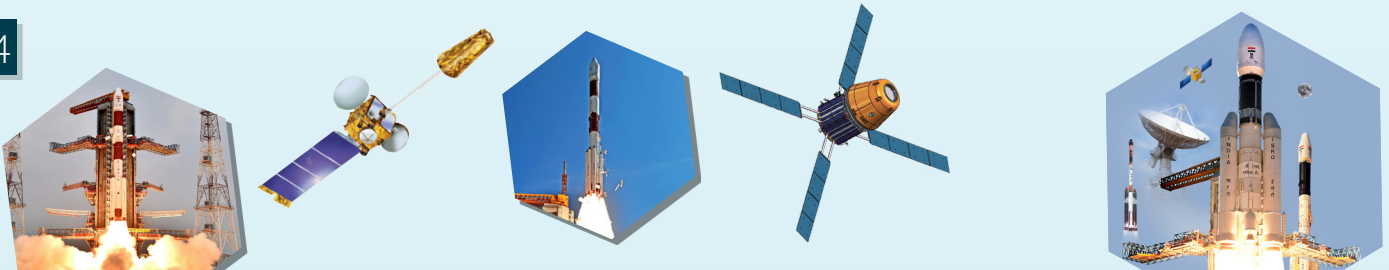



# Rocasin

Rocket case insulation (ROCASIN) is a rubber compound based on the copolymer of acrylonitrile and polybutadiene known as NBR as per ASTM code. It is specially formulated to serve as a rocket motor case insulation having compatibility to propellant grain system. This has, high strength and strain capability and excellent thermal erosion resistance properties as would be desirable in any rocket motor insulation compound. Due to its low coefficient of gas diffusion, ROCASIN finds application as impermeable liners for FRP vessels holding nitrogen at high pressures. Other than sheet form, it finds use as moulded elastomeric flight components like igniter head end insulation, igniter nozzle liners, convergent liners, insulation boot, thermal boot, head end domes etc.

## Applications

Can be used as a thermal insulation barrier layer for various equipments and systems wherever required.

## Technology Transfer from ISRO

ISRO is willing to offer the knowhow of this technology to suitable entrepreneurs / industries in India. Capable manufacturing industries interested in acquiring this knowhow may write with details of their present activities, requirements and plans for implementation, infrastructure and technical expertise available with them, their own market assessment, if any, and plans for diversification to the address given below:

NewSpace India Limited (NSIL)

Email: [contact-nsil@isro.gov.in](mailto:contact-nsil@isro.gov.in)

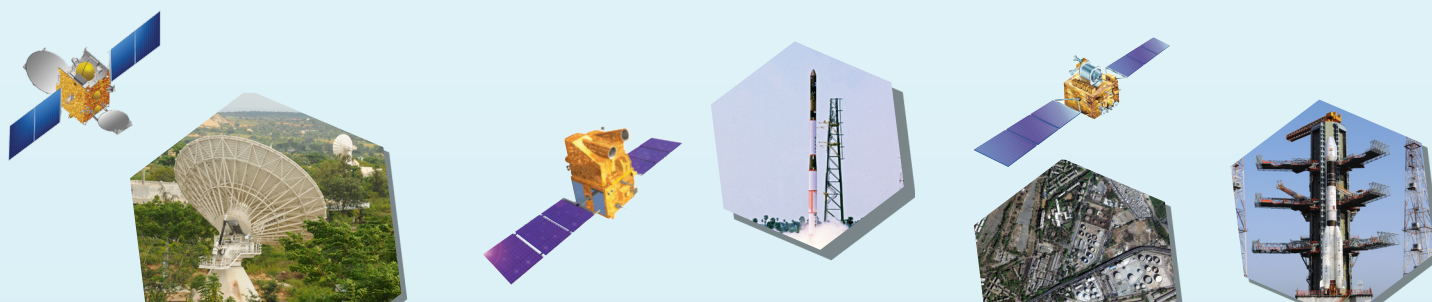

# 5-Aminotetrazole Nitrate

5-Aminotetrazole Nitrate (ATN) is a nitrogen rich oxidizer having the empirical formula  $CH_4N_6O_3$ . An ingredient in gas generating solid propellant/charge composition. Burns faster and yields only non-corrosive gases free from HCl upon combustion. Thus making it ideal ingredient for Green Propellant.

## Salient Features

- Nitrogen rich energetic oxidizer.
- Non hygroscopic in nature, hence alternate to Ammonium nitrate. Non HCl producing, good alternate to Ammonium Perchlorate.
- Acts as monopropellant.
- Compositions made out of ATN are fast burning.

## Properties

Sl. No.	Properties of ATN	
1.	Colour	Colourless
2.	State	Crystalline powder
3.	Molecular Weight	148
4.	N-content (%)	56.7
5.	O-content (%)	32.4
6.	Heat output (cal/g)	1000±50
7.	Friction sensitivity (kgf)	> 36
8.	Impact sensitivity (kg.cm)	> 50
9.	Decomposition Temperature (oC)	175

## Applications

- Can be used as energetic material in power cartridges.
- Can be used as oxidizer for making cool gas generating propellant.

## Technology Transfer from ISRO

ISRO is willing to offer the knowhow of this technology to suitable entrepreneurs / industries in India. Capable manufacturing industries interested in acquiring this knowhow may write with details of their present activities, requirements and plans for implementation, infrastructure and technical expertise available with them, their own market assessment, if any, and plans for diversification to the address given below.

NewSpace India Limited (NSIL)

Email: [contact-nsil@isro.gov.in](mailto:contact-nsil@isro.gov.in)

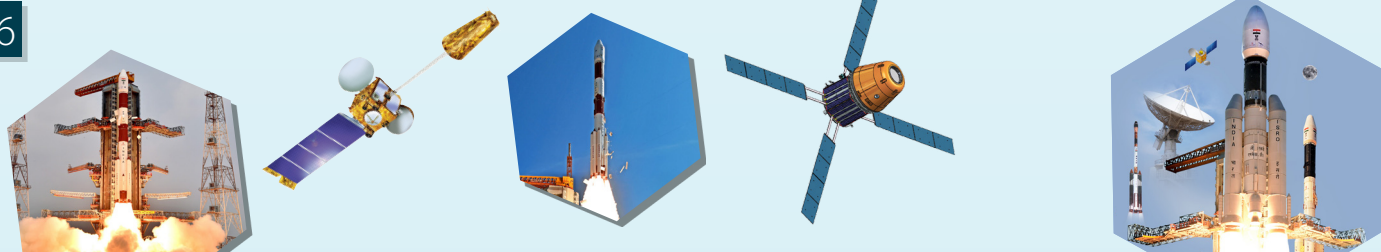

# BMT- Ceramics

Dielectric ceramics find application as resonators (DR), substrates, antennas etc. in terrestrial as well as space communications systems ranging from UHF to mm-band frequencies. Their advantages are small size, light weight, temperature stability etc. Globally, a few materials have been manufactured for use in specific range of microwave spectrum.

Barium Magnesium Tantalite (BMT) is a typical perovskite ceramic, which is widely used in oscillators, multiplexers, filters etc above 10GHz in satellite and terrestrial microwave communication system. The technology has been developed in collaboration with CMET, Thrissur. This dielectric, coming in the medium permittivity materials, possesses extremely low dielectric loss ( $\tan\delta \sim 10^{-5}$ ) in microwave and millimeter wave frequency ranges.

This indigenously developed BMT is equivalent to 8700 series of Trans-Tech and D series of Murata that are used in 10-25 GHz range.

## Typical properties

- |  |                              |
|--|------------------------------|
| 1 Bulk density (Target)                      | < 8 g/cm <sup>3</sup>        |
| (Achieved)                                   | 7.45 ± 0.1 g/cm <sup>3</sup> |
| Dielectric constant ( $\epsilon_r$ )(Target) | 25 ± 3                       |
| (Achieved)                                   | 24 ± 1                       |
| 2 Unloaded Q-factor ( $Q_u$ )(Target)        | 15,000 @ 5.6 GHz             |
| (Achieved)                                   | 28,000 @ 5.6 GHz             |
| (Achieved)                                   | 22,000 @ 7.5 GHz             |
| 3 Unloaded Q-factor ( $Q_u$ )(Target)        | 8,000 @ 10 GHz               |
| (Achieved)                                   | 20,000 @ 10 GHz              |
| 4 Temp. coeff. of freq. ( $\tau_f$ )(Target) | < 7 ppm/K                    |
| (Achieved)                                   | 6 ± 1.0 ppm/K                |

VSSC is willing to offer the technology of BMT ceramics to eligible interested parties who are in the field of manufacturing similar items

Interested entrepreneurs are requested to contact the address given below with all relevant particulars regarding their line of current activity, infrastructure available, market assessment of the product, financial arrangements made, turn over and sales of their products for the past years and a copy of their latest annual report.

## Technology Transfer from ISRO

ISRO is willing to offer the knowhow of this technology to suitable entrepreneurs / industries in India. Capable manufacturing industries interested in acquiring this knowhow may write with details of their present activities, requirements and plans for implementation, infrastructure and technical expertise available with them, their own market assessment, if any, and plans for diversification to the address given below:

NewSpace India Limited (NSIL)

Email: [contact-nsil@isro.gov.in](mailto:contact-nsil@isro.gov.in)

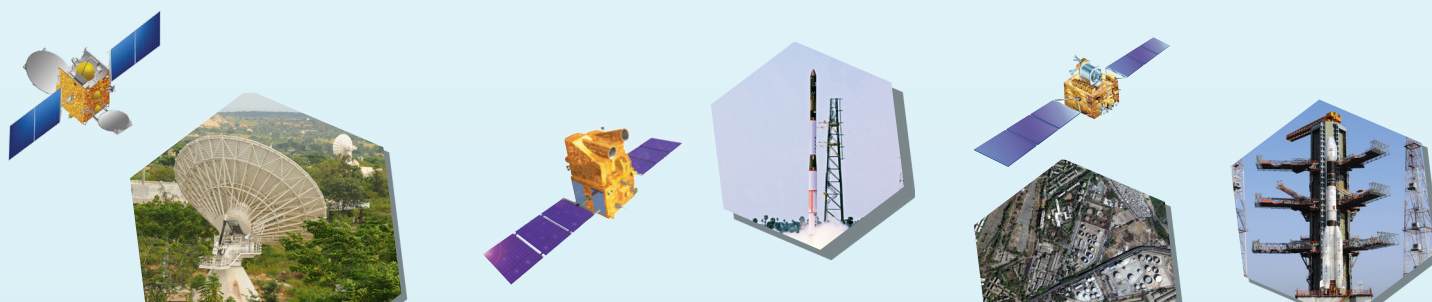

## DK 18- CERAMICS

DK-18 is a MgTiO<sub>3</sub> based ceramic, which is widely used as Patch Antenna substrates in Satellite and GPS communication systems. This dielectric, coming in the medium permittivity materials, possesses extremely low dielectric loss ( $\tan\delta \sim 10^{-5}$ ) in microwave frequency ranges.

Electronic ceramics with high permittivity ( $\epsilon_r > 20$ ) and low dielectric loss ( $\tan\delta < 10^{-3}$ ) have a number of applications in microwave devices like filters, oscillators, multiplexers etc in terrestrial as well as Space communications systems ranging from UHF to mm- band frequencies. In such devices, it is desirable that the ceramics have high  $\epsilon_r$  to confine the electromagnetic waves near them. However, when applications like antennas and substrates are considered,  $10 < \epsilon_r < 20$  is desirable for better radiation field outside the ceramic and size reduction. Their advantages are small size, light weight, temperature stability etc. Globally, a few materials have been manufactured for use in specific range of microwave spectrum. This indigenously developed DK18 is equivalent to Kyocera SM200 and P series of Murata that are used as substrates for GPS antennas.

Since the process temperatures are much lower than the tantalates and raw material cost is also low, the production cost of this ceramics is much lower compared to other similar products in the market. This ceramic also has the added advantage of having a low  $\rho$ , only about a half that of tantalates.

### Typical properties:

Appearance	Light cream
Bulk density (g/cc)	3.7±0.15
Open Porosity	Nil
Closed Porosity	<2%
Resistivity (Ω.cm)	10 <sup>13</sup>
Coeff. of Thermal Expansion (10 <sup>-6</sup> /K)	9.2
Dielectric constant (ε <sub>r</sub> )	19±1.5
Quality factor (Qu @ GHz)	12,000 (6.5)
Loss factor (tanδ, 10 <sup>-5</sup> )	8.4
Temp. coeff. of frequency (τ <sub>f</sub> , ppm/K)	0 ± 5
TE <sub>01</sub> resonator size at 5 GHz (D=2L, mm)	14

VSSC is willing to offer the technology of DK18 ceramics to eligible interested parties who are in the field of manufacturing similar items

Interested entrepreneurs are requested to contact the address given below with all relevant particulars regarding their line of current activity, infrastructure available, market assessment of the product, financial arrangements made, turn over and sales of their products for the past years and a copy of their latest annual report.

NewSpace India Limited (NSIL)  
Email: [contact-nsil@isro.gov.in](mailto:contact-nsil@isro.gov.in)

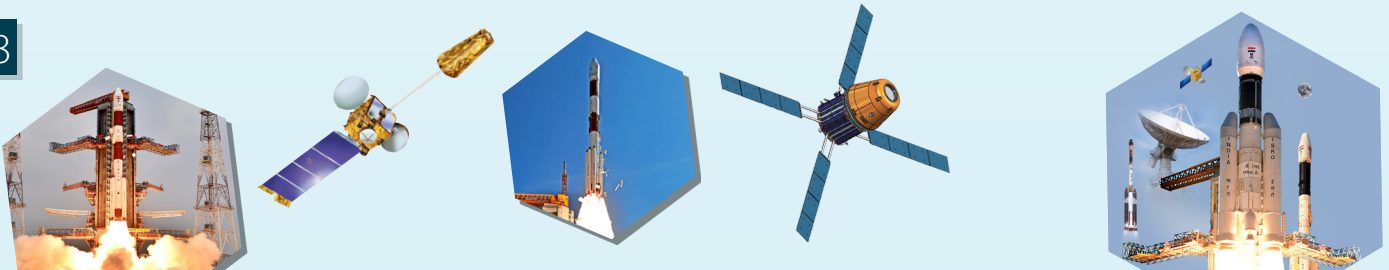

# High-Permittivity Ceramic (DK36) For R F Applications

Dielectric ceramics with high permittivity ( $\epsilon_r > 10$ ) and low dielectric loss ( $\tan \delta < 10^{-3}$ ) have a number of applications in microwave devices. The process technology for realizing DK36 ceramics with dielectric constant  $\epsilon_r$  36-39 has been established. This is similar to imported ceramics like TE36, MDR36, SB350 and 8300 and useful for microwave filters, oscillators etc. The process technology adopted is advanced solid state ceramic route. The ceramics can be fired to full density below 1350°C. DK36 ceramics can find use in devices like filters, oscillators, diplexers, patch antennas etc. The nominal properties of DK36 ceramic are given below.

Bulk density (g/cc)	4.35 – 4.55
Coeff. of thermal expansion ( $10^{-6}/K$ )	8.8 – 9.2
Dielectric constant ( $\epsilon_r$ )	36 – 38
Unloaded Quality factor (Qu @ 4 GHz)	6,000 – 8,000
Loss factor ( $\tan \delta, 10^{-4}$ ) @ 4 GHz	1.25 – 1.5
Temp. coeff. of frequency ( $\tau_f$ , ppm/K)	2 – 7

DK36 ceramics can find use as resonators in filters, oscillators etc. and substrates for patch antennas.

## Technology Transfer from ISRO

ISRO is willing to offer the knowhow of this technology to suitable entrepreneurs / industries in India. Capable manufacturing industries interested in acquiring this knowhow may write with details of their present activities, requirements and plans for implementation, infrastructure and technical expertise available with them, their own market assessment, if any, and plans for diversification to the address given below:

NewSpace India Limited (NSIL)

Email: [contact-nsil@isro.gov.in](mailto:contact-nsil@isro.gov.in)

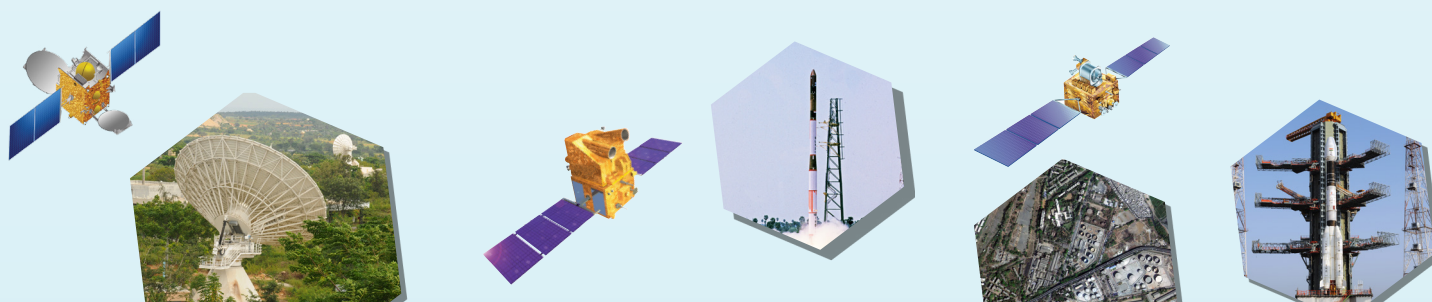

# Cryo Adhesive EPIFIL-9661

(Used as an Adhesive for the End Fitting Reinforcement of Polyimide Pipelines & as a Matrix Resin for the Kevlar Composite over Wrap on Lox Feed Polyimide Pipelines)

Adhesive EPIFIL-9661 is three part room temperature curing adhesive. Part A is a urethane modified epoxy resin, prepared by the co-reaction of epoxy, polyol and isocyanate. Part-B is a mixture of amine hardeners and Part-C is a Silane Coupling agent. This adhesive system presently finds different applications such as matrix resin for Aramid (Kevlar) composite over-wrap

on Liquid Oxygen (LOX) feed polyimide pipelines, for reinforcing the metallic end fittings made of SS-321 and the fibre glass tape to the LOX and LH2 polyimide pipe lines and as a coating material for glass phenolic composite which perform as a thermal isolator between the mix ratio controller and (MRC)/apparent velocity regulator (AVR) valve and the motor in the cryogenic stages of GSLV.

## Salient Features

- Three-component, RT curable, toughened, low viscous polymer liquid adhesive
- Increased pot life [up to approx. 3hrs.]
- Good bond ability with PI film as well as SS materials
- Flight qualified

Properties	Values
Epoxy value (equivalents/kg) of Part-A	3.5 – 4.5
Viscosity at 30 °C (cps) of Part-A	450 –700
Amine Value (mg KOH/g) of Part-B	340-400
Viscosity at 30 °C (cps) of Part-B	350-500

Pot life at 25 °C (minutes)	180 (minimum)
Hardness Shore D (after 7 days cure at RT (30±5 °C)	65 (minimum)
Lap Shear Strength (PI-PI on Aluminium alloy back up) at RT (at 25 °C), (in kg/cm <sup>2</sup> )	40 (minimum)
Lap Shear Strength (PI-Fibre glass tape on SS-321 bac up) at RT (air conditioned room, at 25°C), (in kg/cm <sup>2</sup> )	40 (minimum)

## Technology Transfer from ISRO

ISRO is willing to offer the knowhow of this technology to suitable entrepreneurs / industries in India. Capable manufacturing industries interested in acquiring this knowhow may write with details of their present activities, requirements and plans for implementation, infrastructure and technical expertise available with them, their own market assessment, if any, and plans for diversification to the address given below.

NewSpace India Limited (NSIL)  
Email: [contact-nsil@isro.gov.in](mailto:contact-nsil@isro.gov.in)

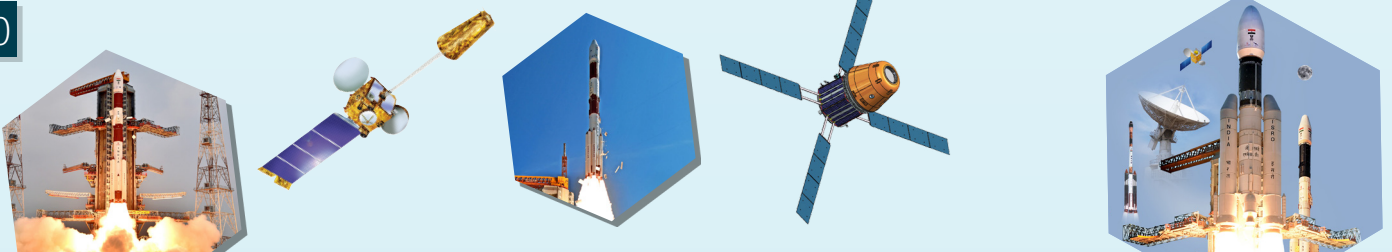

# Matrix resin for composite application EPY PEEKTOH

Indian Space Research Organization at its Vikram Sarabhai Space Centre (VSSC) has developed EPY PEEKTOH resin which is an elevated temperature curing high performance epoxy resin matrix suitable for composite applications. The specialty of the formulation is good mechanical properties, high glass transition temperature and low outgassing properties. This is an ideal matrix resin for processing thick carbon fabric laminates ( $\geq 30$  mm) without any micro cracks and delamination.

## Salient Features

- Elevated temperature curing
- Very good mechanical properties
- High glass transition temperature
- Low outgassing properties
- Suitable viscosity at 60-70°C for processing two dimensional fabric laminates

## Properties

Volatile matter at 65°C for 5 hours	: 0.04
maximum Viscosity at 65°C (poise)	: 60-80
Shore D hardness at 30°C	: > 85
Specific gravity at 30°C	: 1.1 – 1.4
Flexural strength at 25°C (MPa)	: 110 – 120
TML-WVR (%)	: $\leq 1.0$
CVCM (%)	: $\leq 0.1$
Glass transition temperature (°C)	: 210

## Applications

EPY PEEKTOH resin is mainly used for fabrication of composite YOKE panel hinge insert for satellites.

## Technology Transfer from ISRO

ISRO is willing to offer the knowhow of this technology to suitable entrepreneurs / industries in India. Capable manufacturing industries interested in acquiring this knowhow may write with details of their present activities, requirements and plans for implementation, infrastructure and technical expertise available with them, their own market assessment, if any, and plans for diversification to the address given below.

NewSpace India Limited (NSIL)

Email: [contact-nsil@isro.gov.in](mailto:contact-nsil@isro.gov.in)

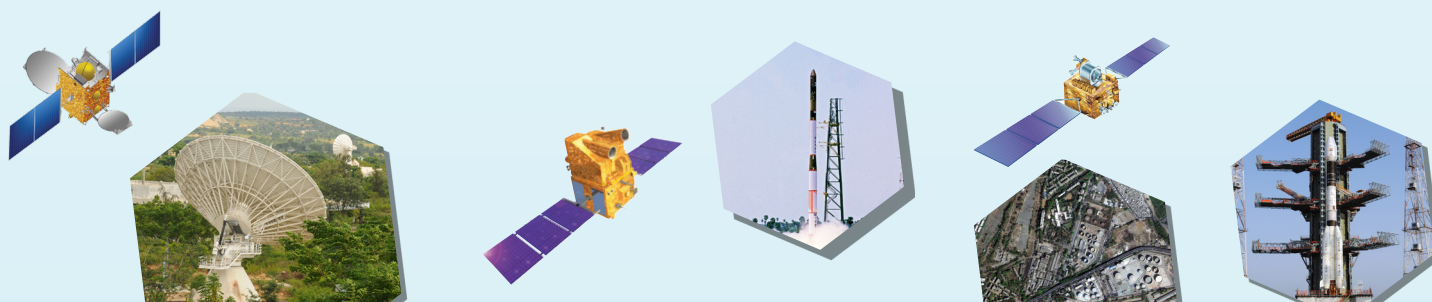

# Guanidinium Azotetrazolate (GZT)

Guanidinium Azotetrazolate (GZT) is a nitrogen rich, carbon poor stable organic compound having the empirical formula (C<sub>4</sub>H<sub>12</sub>N<sub>16</sub>). The decomposition products of GZT are mostly gases consisting of elemental nitrogen as the major product. Since the heat of formation of nitrogen is zero, the decomposition products of GZT are inherently cool and inert. GZT is highly insensitive to mechanical and thermal stimuli and is found as a good fuel additive for gas generator compositions and a good alternate to sodium azide, which is more hazardous to environment.

## Salient Features

- Nitrogen rich organic energetic fuel.
- Produces cool nitrogen gases on decomposition. Insensitive to mechanical and thermal stimuli.
- Good alternate to sodium azide used in gas generators.
- Versatile energetic compositions can be made by adjusting oxygen balance.

## Properties

Sl. No.	Properties of GZT	
1.	Colour	Yellow
2.	State	Amorphous solid
3.	Molecular Weight	284
4.	N-content (%)	78.9
5.	C-content (%)	16.9
6.	Heat output (cal/g)	360 ± 60
7.	Friction sensitivity (kgf)	> 36
8.	Impact sensitivity (kg.cm)	> 320
9.	Decomposition Temperature (°C)	252 ± 6

## Applications

- Fuel for making cool composite gas generators.
- Fuel for making pyrotechnic charges for power cartridges.

## Technology Transfer from ISRO

ISRO is willing to offer the knowhow of this technology to suitable entrepreneurs / industries in India. Capable manufacturing industries interested in acquiring this knowhow may write with details of their present activities, requirements and plans for implementation, infrastructure and technical expertise available with them, their own market assessment, if any, and plans for diversification to the address given below.

NewSpace India Limited (NSIL)  
Email: [contact-nsil@isro.gov.in](mailto:contact-nsil@isro.gov.in)

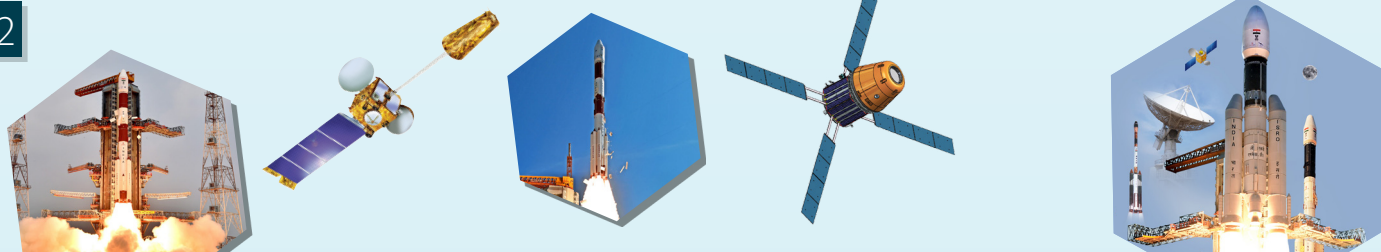



# Polydimethylsilane (PDMS)

(Raw material for polycarbosilane, a precursor of silicon carbide)

Polydimethylsilane (PDMS) is a pre-ceramic polymer precursor developed by Indian Space Research Organisation at its Vikram Sarabhai Space Centre. PDMS finds use in the synthesis of polycarbosilane (PCS) – a well-known polymeric precursor for silicon carbide (SiC). PCS is prepared from PDMS by heating PDMS in an autoclave, or at normal pressure with a catalyst. PCS is a ceramic precursor useful in realizing C/SiC, C/C-SiC and SiC/SiC based thermo-structural components for re-usable launch vehicles, C/SiC turbine blades, and SiC fibers.

## Salient Features

- Fine free flowing powder at room temperature.
- It can be stored in sealed polyethylene bags at room temperature, away from direct sunlight, and has long shelf life.
- PDMS is insoluble in water and other organic solvents such as Acetone, Cyclohexane, Ethyl Acetate, Toluene, Xylene.

Properties	Range
Appearance	White powder
Moisture content (by KF)	<1%
Silicon content (wt%)	42 – 48
Carbon content (wt%)	34 – 41
Hydrogen content (wt%)	9 – 12
Oxygen content (wt%)	<5

## Technology Transfer from ISRO

ISRO is willing to offer the knowhow of this technology to suitable entrepreneurs / industries in India. Capable manufacturing industries interested in acquiring this knowhow may write with details of their present activities, requirements and plans for implementation, infrastructure and technical expertise available with them, their own market assessment, if any, and plans for diversification to the address given below.

NewSpace India Limited (NSIL)

Email: [contact-nsil@isro.gov.in](mailto:contact-nsil@isro.gov.in)

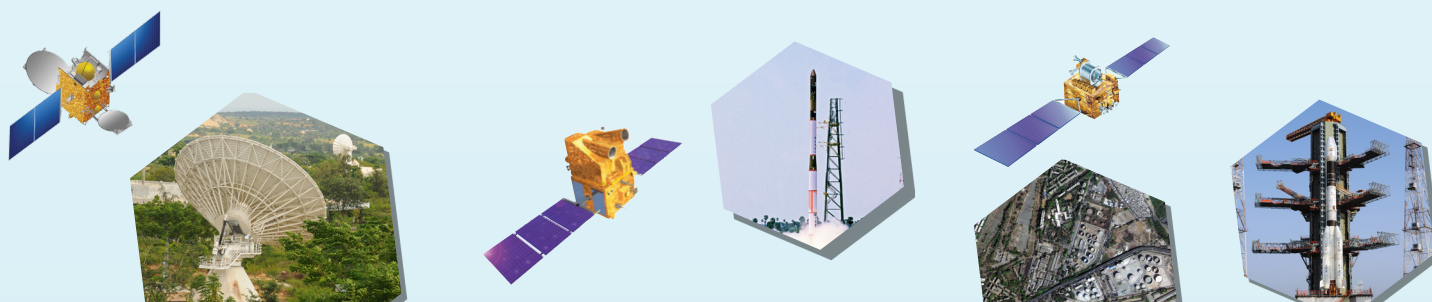

# Phenolic Resin (PF-106)

Phenolic resin (PF-106) is a resol type thermosetting phenol- formaldehyde polymer used for processing high temperature resistant ablative materials such as carbon phenolic and silica phenolic composites. PF 106 is a high temperature curing resin which has excellent ablative properties and char strength.

The production of PF-106 involves the following steps:

1. Melting of Phenol.
2. Charging of formalin and molten phenol into the reactor in the desired mole ratio.
3. Addition of catalyst.
4. Condensation polymerization of phenol and formalin.
5. Neutralization of reaction mixture with acid.
6. Settling of reaction mixture.
7. Removal of water of reaction and salt.
8. Drying of resin to remove traces of water and other volatiles.
9. Addition of required quantity of alcohol
10. Filtration and product packing.
11. Storage

## Salient Features

- Appearance : Yellowish brown to dark brown liquid
- Viscosity : 150 -250
- Specific gravity : 1.12 -1.16
- Total solid content : 60–65 for ½ hr. (%)
- Freephenol (%) : 6 max.
- Free formalin (%) : 3 max.
- Point of trouble : 6–10 ml of water of resin

Storage conditions

Temperature : 10-20 °C

Shelf Life : 3 months

## Applications

The resin finds application as binder for high temperature resistant ablative composites materials such as carbon phenolic, silicaphenolic and epoxy phenolic systems.

## Technology Transfer from ISRO

ISRO is willing to offer the know-how of this technology to suitable entrepreneurs/industries in India. Capable manufacturing industries interested in acquiring this know-how may write with details of their present activities, requirements and plans for implementation, infrastructure and technical expertise available with them, their own market assessment, if any, and plans for diversification to the address given below.

NewSpace India Limited (NSIL)

Email: [contact-nsil@isro.gov.in](mailto:contact-nsil@isro.gov.in)

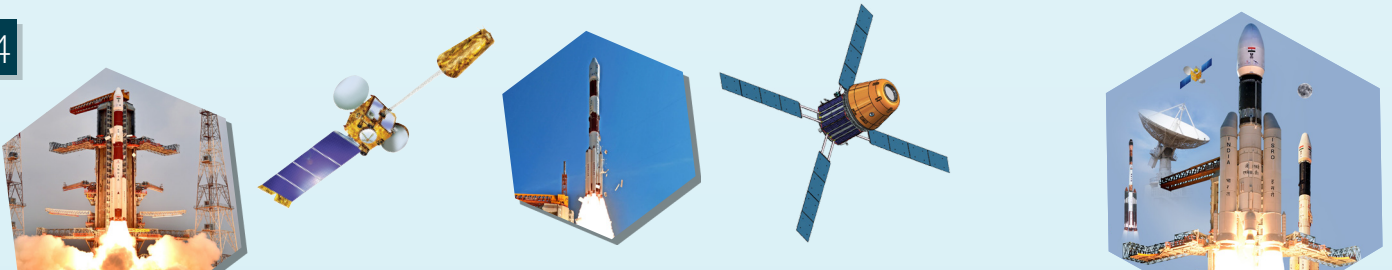

# Phenolic Matrix Resin (PF-108)

Vikram Sarabhai Space Centre has developed different types of resins catering to specific applications in Launch Vehicles and Satellites. These materials may also find various industrial applications such as bonding, sealing, coating, potting, laminating, molding, etc.

PF-108 is a special grade liquid phenolic matrix resin which is used as a precursor for production of silica phenolic throat inserts for the liquid engines of ISRO launch vehicles.

## Operational steps for synthesising PF 108

1. Melting of Phenol.
2. Charging of formalin and molten phenol into the reactor in the desired mole ratio.
3. Addition of catalyst.
4. Condensation polymerization of phenol and formalin.
5. Neutralization of reaction mixture with acid to desired pH.
6. Settling of reaction mixture
7. Removal of water of reaction and sodium salt by decantation.
8. Vacuum drying of resin to remove the final traces of water and other volatiles.

Major equipments needed are phenol melting vessel and reaction vessel.

1. Melting vessel for phenol melting.
2. Jacketed SS reactor fitted with cooling coils, stirrer, motor, condenser and receiver for polymerisation and drying. The reactor is suitably linked with the utility system during operation. It is also equipped with load cell, vacuum systems, temp controllers, cooling systems pressure/vacuum gauges, etc.
3. Decanter vessel for removal of water.
4. Water jet ejector for vacuum.

## PF 108 Product Specifications

Appearance	: Yellowish brown to dark brown liquid
Viscosity at 30 DC	: 400 – 600 cps
Specific gravity at 30 DC	: 1.18 – 1.20
Refractive Index at 30 DC	: 1.570 – 1.575
Total solids	: 72 – 75%
Free phenol (%)	: 18 – 22%
Free formalin (%)	: 0.5% (max.)
Ash Content	: 0.5% (max.)
Point of trouble	: 13 – 15.5 ml of water/10 ml solution
pH (5% solution)	: 7.3 – 7.8
Sodium Content	: 0.4% (max.)
Water Content	: 14% (max.)
Storage conditions	
Temperature	: <15°C
ShelfLife	: 3 months (in above condition)

## Technology Transfer from ISRO

ISRO is willing to offer the know-how of this technology to suitable entrepreneurs / industries in India. Capable manufacturing industries interested in acquiring this knowhow may write with details of their present activities, requirements and plans for implementation, infrastructure and technical expertise available with them, their own market assessment, if any, and plans for diversification to the address given below.

NewSpace India Limited (NSIL)

Email: [contact-nsil@isro.gov.in](mailto:contact-nsil@isro.gov.in)

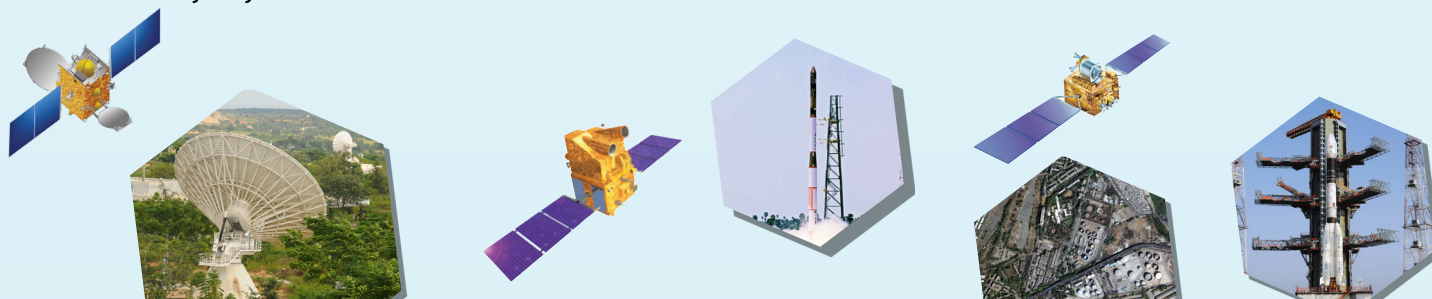

# RTV Silicone Single Part Adhesive, Silcem R9

Indian Space Research Organisation at its Vikram Sarabhai Space Centre (VSSC) has developed a room temperature curable single part adhesive, SILCEM R9 based on polysiloxane for multipurpose bonding applications. This system contains polysiloxane, fillers and curing components mixed under dehumidified conditions and filled inside squeeze tubes for ready – to – use condition. The adhesive can be squeezed out from the tube and very conveniently applied directly on the substrates and bonded. On exposure to humid air, it hardens by itself to a solid rubbery mass.

## Salient Features

- Single part siloxane based system containing fillers and special curing components.
- Room temperature curable on exposure to humid air. Safe inside the tube
- Easy to apply. Simply squeeze and apply
- Supplied in ready-to -use squeeze tubes of 100-150 g capacity
- Meets the aerospace quality standards

## Typical Properties

Density (cured product) g/cc	: 1.25 - 1.35
Tensile strength @RTksc	: 22 - 42
Tensile strength@120°Cksc	: 18 - 35
Elongation@RT%	: 225 - 350
Elongation@120°C%	: 110 - 300
Lap shear strength (Al-Al) @RTksc	: 13 - 30
Lap shear strength(Al-Al) @120°Cksc	: 13 - 28
Thermal conductivity at 100°CW/m.K	: 0.25 - 0.50
Specific heat at 100°C,J/g/°C	: 1.0 - 2.0
Hardness, ShoreA	: 40 - 55

## Applications

This adhesive finds large societal applications for use as sealants to provide leak proof joints. This material can also be used as a gap filler materials where high temperatures are experienced. Being a water repellent adhesive material, the bonded substrates maintains good strength even under wet conditions. It finds applications as a general purpose adhesive for bonding / sealing materials like wood, metals, leathers, foams etc.

## Technology Transfer from ISRO

ISRO is willing to offer the knowhow of this technology to suitable entrepreneurs /industries in India. Capable manufacturing industries interested in acquiring this knowhow may write with details of their present activities, requirements and plans for implementation, infrastructure and technical expertise available with them, their own market assessment, if any, and plans for diversification to the address given below.

NewSpace India Limited (NSIL)

Email: [contact-nsil@isro.gov.in](mailto:contact-nsil@isro.gov.in)

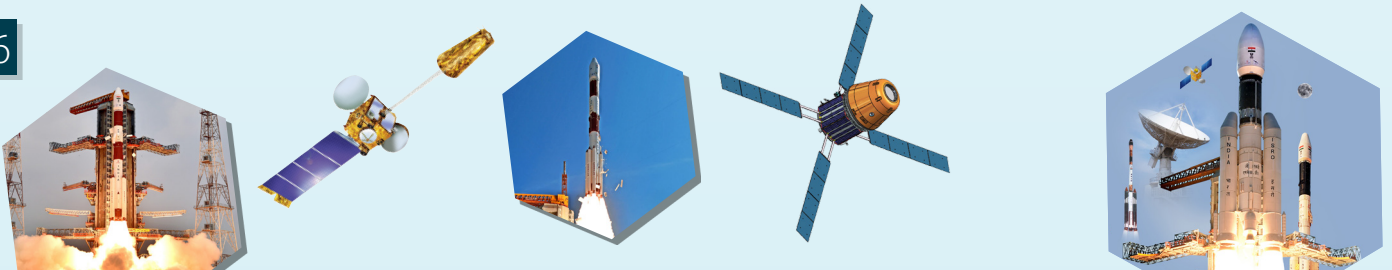

# Silica Fibres

Indian Space Research Organisation at its Vikram Sarabhai Space Centre (VSSC) has developed a new technology for developing silica fibres by sol-gel process. The fibres can be used for high temperature insulation up to 1500°C.

The low temperature process (400°C) adopted for developing silica fibres is more economical than the conventional technologies and can give high purity fine fibres. In addition, the fibres are hollow as well, thereby improving the insulation property further.

## Fibre Specifications:

- Composition : Silica (99.5%)
- Diameter : 1 - 20  $\mu$
- Length : 5 - 20 mm
- Aspect ratio : 500 - 20,000
- Morphology : Amorphous (1400 °C)
- Heat Treatment : Up to 1400 °C

The technology of developing silica fibres is available for transfer to entrepreneurs working in a similar field. Interested entrepreneurs are requested to contact the address given below with relevant particulars regarding their line of current activity, infrastructure available, market assessment of the product, financial arrangements made and turn over and sales of their products for the past years.

## Technology Transfer from ISRO

ISRO is willing to offer the knowhow of this technology to suitable entrepreneurs / industries in India. Capable manufacturing industries interested in acquiring this knowhow may write with details of their present activities, requirements and plans for implementation, infrastructure and technical expertise available with them, their own market assessment, if any, and plans for diversification to the address given below:

NewSpace India Limited (NSIL)  
Email: [contact-nsil@isro.gov.in](mailto:contact-nsil@isro.gov.in)

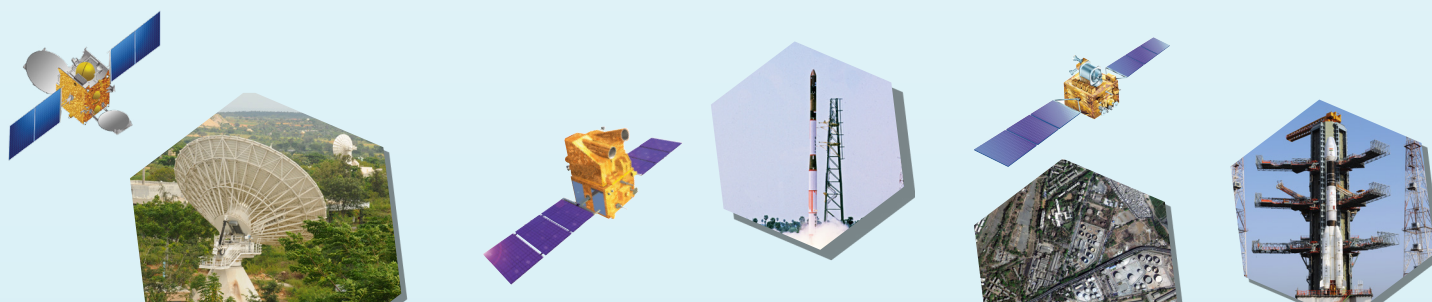

# Silica Granules

Indian Space Research Organisation at its Vikram Sarabhai Space Centre (VSSC) has developed a new technology for developing silica granules of fine sizes. The granules are produced from aero-gel chips and subsequently firing using microwaves. They can be used for high temperature insulation up to 1250°C. Since they are hollow and weigh very less, they can also be used as filler materials for paints, polymer/metal and ceramic matrices to reduce density and improve thermal properties.

### Product specifications:

- Product Composition :  $\text{SiO}_2$  (99.5%)
- Diameter : <2 mm
- Bulk Density : <0.35 g/cc
- Morphology : Hollow, fibrous & Amorphous

The technology of developing silica granules is available for transfer to entrepreneurs working in a similar field. Interested entrepreneurs are requested to contact the address given below with relevant particulars regarding their line of current activity, infrastructure available, market assessment of the product, financial arrangements made and turn over and sales of their products for the past years.

## Technology Transfer from ISRO

ISRO is willing to offer the knowhow of this technology to suitable entrepreneurs / industries in India. Capable manufacturing industries interested in acquiring this knowhow may write with details of their present activities, requirements and plans for implementation, infrastructure and technical expertise available with them, their own market assessment, if any, and plans for diversification to the address given below:

NewSpace India Limited (NSIL)

Email: [contact-nsil@isro.gov.in](mailto:contact-nsil@isro.gov.in)



# Silica Aerogel By Ambient Pressure Drying Method

Indian Space Research Organization at its Vikram Sarabhai Space Centre (VSSC) has developed hydrophobic silica aerogel in granular/powder form by a simple and cost-effective ambient pressure drying process.

## SALIENT FEATURES

Silica aerogels are exotic materials with a unique combination of properties.

As a virtue of high porosity and extremely small pores, aerogels exhibit extremely low thermal conductivity, making them a 'super-insulator'. In addition to thermal insulation, aerogels are also superior sound insulators and they possess very low refractive index and an excellent dielectric medium which finds numerous applications.

VSSC has developed a conventional drying technology at ambient pressure to get rid of the solvents within the gel. This makes the process amenable to bulk-production in a cost-effective manner. The solvents used in the production can be recycled using this technology, thus making the process environmental friendly.

PROPERTY	VALUE ACHIEVED
Bulk density, g/cm <sup>3</sup>	0.06 – 0.20
BET surface area, m <sup>2</sup> /g	400 – 1000
Mean pore size, nm	10 – 40
Percentage porosity	>90 %
Contact Angle	>130°
Thermal conductivity, W/mK (RT, 1 atm)	<0.05
Dielectric constant (@ 1 MHz)	1 – 1.4

## APPLICATIONS

- Bulk-fill insulation (thermal and acoustic).
- As fillers in concrete, cement, paints, adhesives, foams, ablatives, rubber, coatings etc. for decreasing density, thermal conductivity & flammability, and increasing the heat resistance of the material.
- As precursors to produce aerogel based sheets that can be used as foot- insoles, boot / jacket insulation or as winter / Arctic apparel at areas having extremely cold climate.
- In window glazing as insulator between glass/ polyacrylate panels, which allow natural light but not heat (for hot places-where A/C is used), and in trapping heat (in cold places), which allow in significant electricity and money saving.
- As fillers in cosmetic items such as sunscreen creams, foundation, toothpastes etc.
- Carrier for drug delivery.
- Vibration/acoustic damping materials.

## Technology Transfer from ISRO

ISRO is willing to offer the knowhow of this technology to suitable entrepreneurs / industries in India. Capable manufacturing industries interested in acquiring this knowhow may write with details of their present activities, requirements and plans for implementation, infrastructure and technical expertise available with them, their own market assessment, if any, and plans for diversification to the address given below:

NewSpace India Limited (NSIL)  
Email: [contact-nsil@isro.gov.in](mailto:contact-nsil@isro.gov.in)

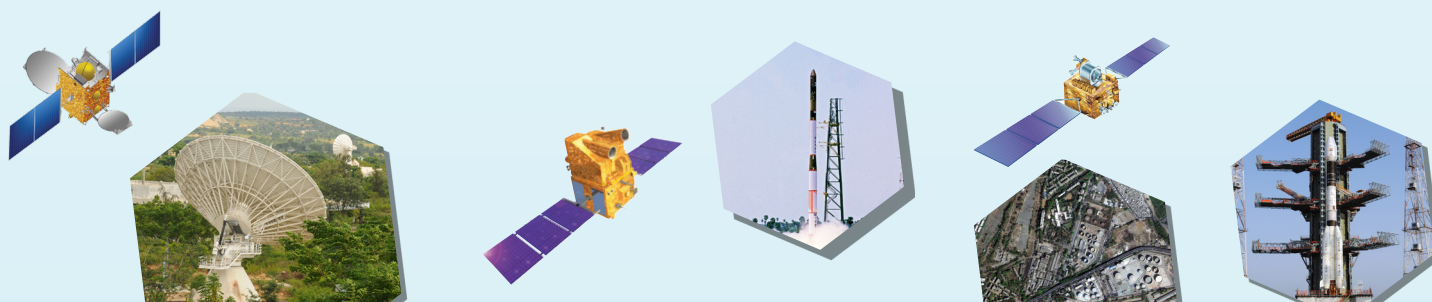

# Silica Aerogel Based Composite Sheet

Indian Space Research Organization at its Vikram Sarabhai Space Centre (VSSC) has developed hydrophobic silica aerogel by a simple and cost-effective ambient pressure drying process. Using the developed aerogel powders, flexible, hydrophobic aerogel sheets have also been developed.

## Salient Features

The composite sheets are made from Silica aerogel which is an exotic materials with a unique combination of properties. Low density and thermal conductivity coupled with high porosity and surface area make aerogel a 'super-insulator'. However, their cost, brittle and friable nature has limited its use to specialized applications.

VSSC/ISRO has developed the technology to develop flexible and hydrophobic sheets from the aerogel powder which expands a gamut of applications, making it suitable to be used as an ideal replacement for conventional insulation. The lab scale technology developed has been demonstrated in thermal protection system since PSLV C39.

Aerogel sheets are ideal to be used as wrap around insulation, which can be cut to desired size and integrated. Aerogel sheets developed in ISRO on the other hand are non-dusting and are easy to handle.

## Properties

PROPERTY	VALUE ACHIEVED
Areal density, g/m <sup>2</sup> (gsm)	150 – 500
Thickness, mm	0.6 – 10
Thermal Conductivity (@ RT), W/mK	~0.03 (TPS method)
Dielectric Constant (@ 10 GHz)	1.3 – 1.6

## Applications

- Wrap around insulation for use in pipelines/ feed-lines etc.
- For use as insulating layer in foot- insoles, boot / jacket insulation or as winter / Arctic apparel at areas having extremely cold climate.
- As low dielectric constant substrates over which circuits can be printed.
- Cryogenic thermal insulation.
- In multi-layer insulation.

## Technology Transfer from ISRO

ISRO is willing to offer the knowhow of this technology to suitable entrepreneurs / industries in India. Capable manufacturing industries interested in acquiring this knowhow may write with details of their present activities, requirements and plans for implementation, infrastructure and technical expertise available with them, their own market assessment, if any, and plans for diversification to the address given below:

NewSpace India Limited (NSIL)  
Email: [contact-nsil@isro.gov.in](mailto:contact-nsil@isro.gov.in)

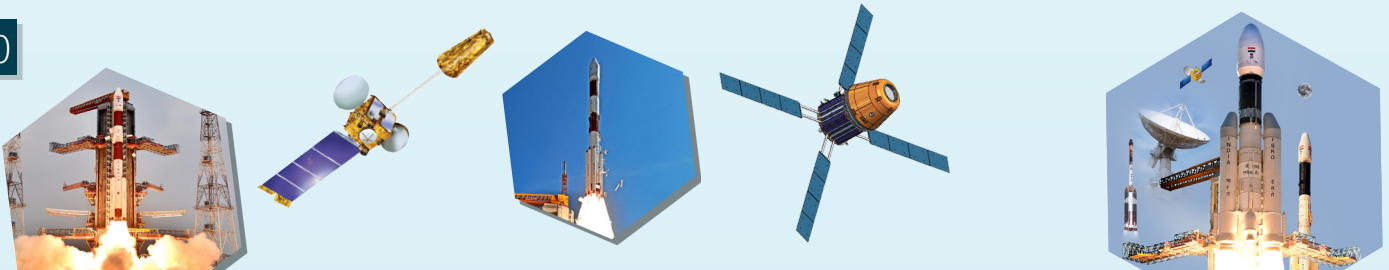



# Waterproofing Compound RWPC-03

RWPC-03 is a waterproofing compound developed by VSSC for the waterproofing of silica tiles and silica felt/fabric based flexible insulations. It is an alkoxy silane based system, processed by controlled hydrolysis of siloxanes. This is an environment friendly method and imparts efficient waterproofing of the system. The treatment involves spraying the aqueous solution of an organo-polysiloxane waterproofing compound on the substrate (preferably glass and silica based) and heating them to form a waterproofed article. In the case of silica tiles and silica felt/fabrics, water absorption could be brought down from 350% to <5% and <10% respectively using this compound. It is not a conventional surface coating method and makes both surface as well as bulk of the material water resistant.

## Typical properties / characteristics:

Color and consistency	: Transparent liquid
Viscosity of water proofing compound	: <5cP
Weight increase due to water proofing	: 3% max by weight
Water absorption of water proofed silicatile	: <5 % by weight
Water absorption of water proofed flexible insulation	: <10% by weight

## Applications

RWPC-03 can potentially be used as general purpose water proofing compound for silica based components including composites.

## Technology Transfer from ISRO

ISRO is willing to offer the knowhow of this technology to suitable entrepreneurs / industries in India. Capable manufacturing industries interested in acquiring this knowhow may write with details of their present activities, requirements and plans for implementation, infrastructure and technical expertise available with them, their own market assessment, if any, and plans for diversification to the address given below.

NewSpace India Limited (NSIL)

Email: [contact-nsil@isro.gov.in](mailto:contact-nsil@isro.gov.in)

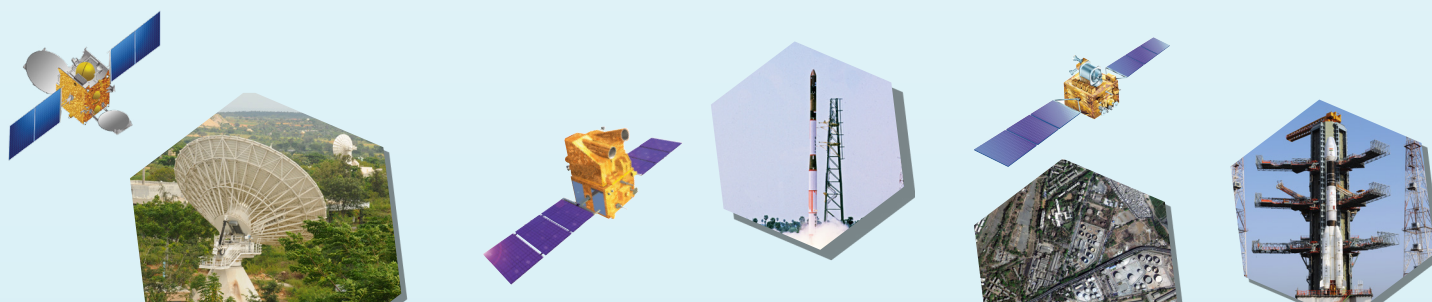

# Sealant EPY 2121N

EPY 2121N is a two-part epoxy-amine based sealant containing mica filler which impart high insulation resistance. This castable compound is designed to have pourable consistency and long work life, which result in void free filling of the cavities. Cure is achieved by the application of heat and the sealant exhibits good high and low temperature service capability.

## Typical Properties / characteristics:

PROPERTY	
Colour and consistency	Grey viscous liquid
Viscosity at 30°C (ps)	5000 – 10000
Pot life	>3 hours.
Epoxy value (eq./kg)	3 – 4.5
Cure	Ambient (25-35°C) / 18-24hrs followed by 60-65°C/5hrs
Lap shear strength on A1-A1 at RT	>100 ksc.

## Technology Transfer From ISRO

ISRO is willing to offer the knowhow of this technology to suitable entrepreneurs / industries in India. Capable manufacturing industries interested in acquiring this knowhow may write with details of their present activities, requirements and plans for implementation, infrastructure and technical expertise available with them, their own market assessment, if any, and plans for diversification to the address given below:

NewSpace India Limited (NSIL)  
Email: [contact-nsil@isro.gov.in](mailto:contact-nsil@isro.gov.in)

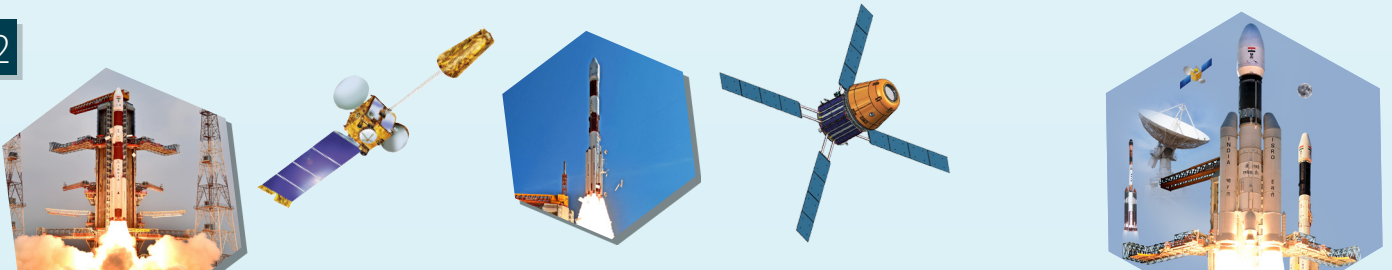

# Adbond EPP-3521

ADBOND EPP 3521 is a rubber based adhesive system developed for mounting various electronic systems to the structural elements. It is having very good thermal conductivity with good electrical insulation property and also possess very low out gassing characteristics.

This is an elastomer modified epoxy system consisting of insulative oxide filler in high concentration with silane coupling agent to provide electrical insulation and thermal conductivity.

ADBOND EPP 3521 will find usage in electric/ electronic gadgets manufacturing areas where potting/ bonding with good thermal dissipation and electrical insulation are warranted.

## Typical Properties / Characteristics:

PROPERTY	
Color & consistency	Black & pasty
Viscosity of the resin (ps)	700 to 8000
Sp. Gravity	1.8
Hardness (Shore D)	
Lap shear strength (ksc) on Alumina at RT	> 80
Thermal conductivity (cal/cm/C/s)	$1.04 \times 10^{-3}$
Volume Resistivity (ohm-cm)	$1.5 \times 10^{13}$
Out gassing - TML (%) - CVCM (%)	< 1 $\leq 0.1$
Cure	Ambient
Pot Life (min.)	45
Service temperature	223 K to 338 K

## Technology Transfer from ISRO

ISRO is willing to offer the knowhow of this technology to suitable entrepreneurs / industries in India. Capable manufacturing industries interested in acquiring this knowhow may write with details of their present activities, requirements and plans for implementation, infrastructure and technical expertise available with them, their own market assessment, if any, and plans for diversification to the address given below:

NewSpace India Limited (NSIL)  
Email: [contact-nsil@isro.gov.in](mailto:contact-nsil@isro.gov.in)

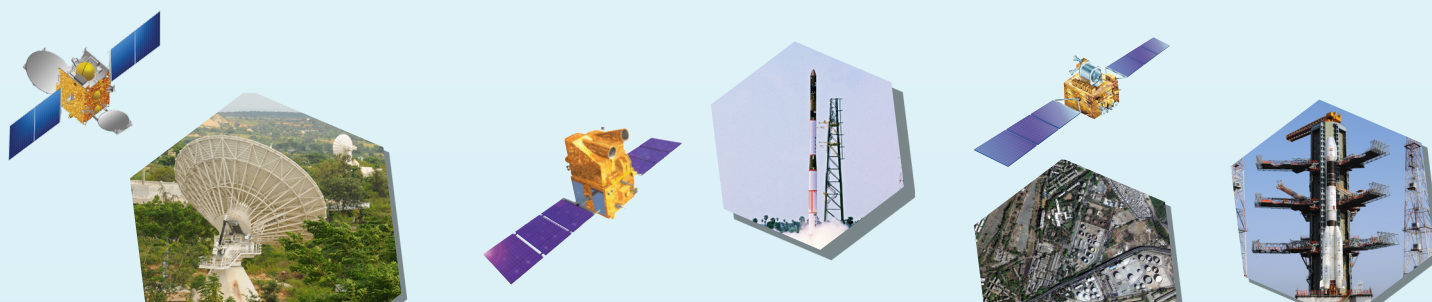

# Umbilical Pads

Umbilical pads are semi-rigid foams which are developed based on polyurethane (PU) polymeric systems having energy absorbing capabilities. These are integral skin foams that can be used for absorbing shock and impact energy hence they are used for controlling vibration and for acoustic insulation. These pads are semi flexible water blown foam system produced by the polymerization reaction between hydroxyl bearing polymeric compounds called polyols and di or polyisocyanates in the presence of catalysts.

Umbilical pads are designed to absorb impact energy of the separating umbilical lines used in launch vehicles. These foam pads of required size and dimensions are moulded with clamps at the corners for assembling the pads at required locations in the launch pad. These shock absorbing pads can also be utilized for transportation of electronic packages.

## Technological Highlights of the product if any

1. Semi flexible and shock absorbing foam
2. RT curable
3. Can be moulded to the required shape and size

## Typical Properties

Nature of foam	Semi-flexible PU foam with blue coloured fire-retardant coating
Dimensions	1200 mm x 1200 mm x 100 mm
Density (uncoated)	55 - 80 kg/m <sup>3</sup>
Flame test with coating	Self-extinguishing within 5-6 sec
% Ball rebound with coating	20 - 30
Shelf life	5 years

## Technology Transfer from ISRO

ISRO is willing to offer the knowhow of this technology to suitable entrepreneurs / industries in India. Capable manufacturing industries interested in acquiring this knowhow may write with details of their present activities, requirements and plans for implementation, infrastructure and technical expertise available with them, their own market assessment, if any, and plans for diversification to the address given below:

NewSpace India Limited (NSIL)  
Email: [contact-nsil@isro.gov.in](mailto:contact-nsil@isro.gov.in)

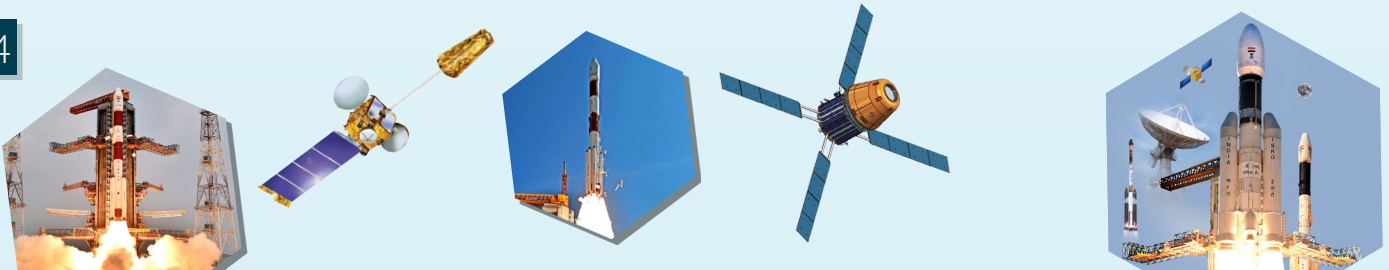

# Low Density Epdm Based Thermal Insulation

The technology offered is for a light weight/low density solid rocket motor thermal insulation material based on EPDM rubber. The rubber compound shall be processed in the form of sheets of required thicknesses by calendering or extrusion. The sheets shall be used of insulation laying process following the same processing temperature and conditions as followed during NBR based systems. The material interface properties: rubber-to-metal and rubber-to-propellant match with conventional NBR based systems.

The advantage over the conventional NBR system is its 15% lower density values, resulting in lesser inert mass. Also the thermal insulation capability is 10-15% better than elsewhere similar insulations.

The material also exhibit better aging resistance and low temperature characteristics. Other than in sheet form use, it finds utility as moulded elastomeric flight components like igniter head end insulation, igniter nozzle liners, convergent liners, insulation boot, thermal boot, head end domes etc.

## Applications

- Can be used as a thermal insulation barrier layer for various equipments and systems wherever required.

## Technology Transfer from ISRO

ISRO is willing to offer the knowhow of this technology to suitable entrepreneurs / industries in India. Capable manufacturing industries interested in acquiring this knowhow may write with details of their present activities, requirements and plans for implementation, infrastructure and technical expertise available with them, their own market assessment, if any, and plans for diversification to the address given below.

NewSpace India Limited (NSIL)

Email: [contact-nsil@isro.gov.in](mailto:contact-nsil@isro.gov.in)

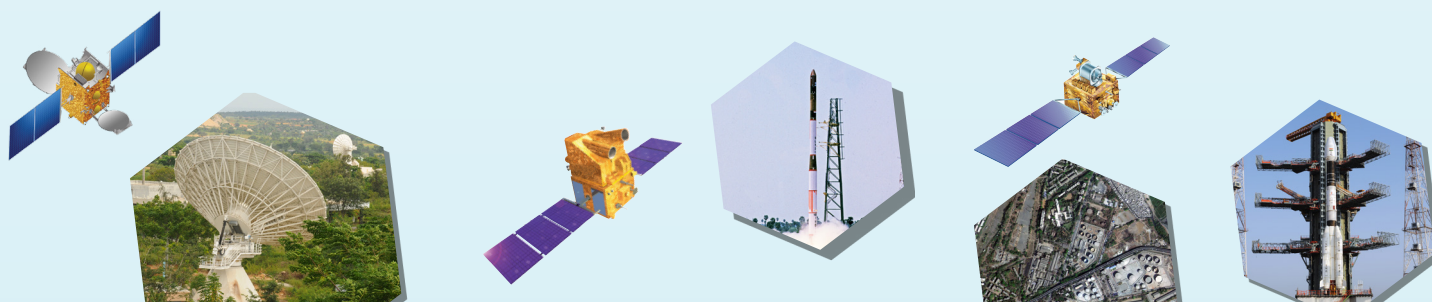

# Coating Compound EPY 1061

Vikram Sarabhai Space Centre has developed different types of adhesive compounds catering to specific applications in Launch Vehicles and Satellites. These materials may also find various industrial applications such as bonding, sealing, coating, potting, laminating, molding etc. The following are some of the new formulations tailored to meet specific requirements as adhesive, sealant, coating and potting compounds. These are derived from resins and different curing agent combinations, modified with various classes of materials such as flexibilizer, toughening agent, fillers, pigments, cure accelerators etc.

EPY1061 is an amidoamine modified epoxy based system specially developed to protect the metal surfaces from corrosion in aqueous strontium perchlorate medium. This coating and sealing system consists of two main components Part A (resin) and Part B (hardener) and a third component Part C which is a solvent. Parts A, B and C are mixed in a specified ratio and sprayed into the metal surface using spray gun to get corrosion resistant coating. The coating adheres well to the metal substrate and reaches fully cured condition at room temperature in 72 hours

## Typical Properties / characteristics:

PROPERTY	
Colour and consistency	Red coloured viscous liquid
Viscosity at 25 °C (cps)	20000-40000
Pot life/ Gel time	> 25 minutes.
Flow Time, Part A, B & C mixed	35 – 50 seconds.
Cure	Ambient
Lap shear strength on Al-Al at RT	> 90 ksc.

## Technology Transfer from ISRO

ISRO is willing to offer the knowhow of this technology to suitable entrepreneurs / industries in India. Capable manufacturing industries interested in acquiring this knowhow may write with details of their present activities, requirements and plans for implementation, infrastructure and technical expertise available with them, their own market assessment, if any, and plans for diversification to the address given below:

NewSpace India Limited (NSIL)  
Email: [contact-nsil@isro.gov.in](mailto:contact-nsil@isro.gov.in)

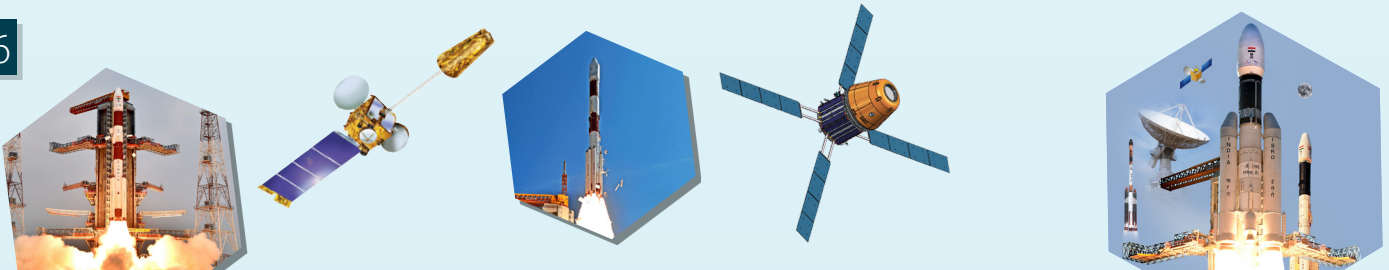

# Benzoxazine Polymer

Indian Space Research Organisation at its Vikram Sarabhai Space Centre has developed Benzoxazine Polymer, a matrix resin suitable for thermal insulations, adhesive formulations and encapsulant in PCB industry.

Polybenzoxazine is a suitable candidate matrix resin for high density ablative composites and also for light weight foam composites in aerospace applications due to excellent thermal and thermo-oxidative stability, high char yield, good chemical inertness, abrasion resistance and flame retardancy. It also finds application as an encapsulant in electronic industry.

## Salient Features

- Excellent flame retardancy
- Easily processable (solventless process, moderate temperature)
- Good thermal stability

## Typical Properties / characteristics:

Raw materials	Bisphenol A, Aniline and Para-Formaldehyde
Method	Solventless process
Reaction temperature:	120 °C
Product appearance	Yellowish orange powder
Solubility	Soluble in acetone, chloroform etc
Curing temperature:	210 °C/3 hrs

Polymerization temperature (°C)	200/ 2 hours
Thermal stability	>250 °C.
Shelf life	1 year
Storage	Ambient temperature, moisture-free environment
Approximate Production cost	Rs.1000/kg

## Technology Transfer from ISRO

ISRO is willing to offer the knowhow of this technology to suitable entrepreneurs /industries in India. Capable manufacturing industries interested in acquiring this knowhow may write with details of their present activities, requirements and plans for implementation, infrastructure and technical expertise available with them, their own market assessment, if any, and plans for diversification to the address given below.

NewSpace India Limited (NSIL)

Email: [contact-nsil@isro.gov.in](mailto:contact-nsil@isro.gov.in)

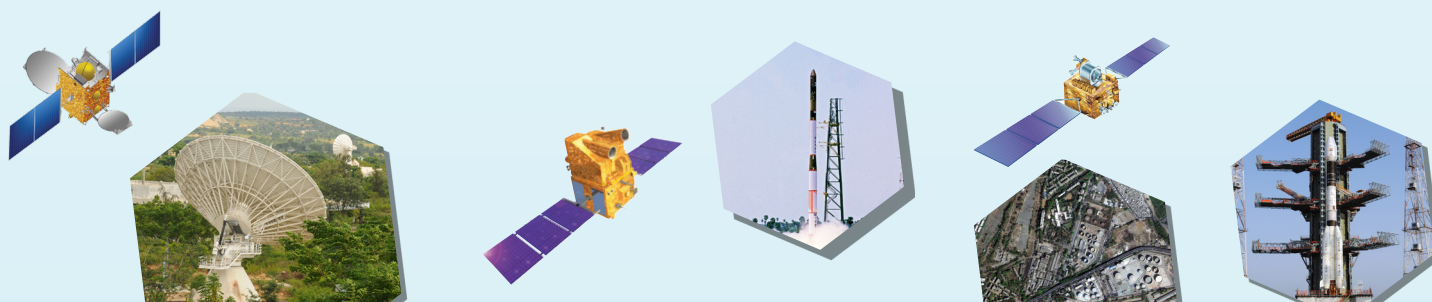

# Compensated Alumina (ComAl) for Electronic Applications

Alumina (Al<sub>2</sub>O<sub>3</sub>) is a versatile ceramic and a 'workhorse' ceramic that finds place in a wide range of applications— mechanical, thermal, electrical, electronic and even optic. Indian industries are well-versed in alumina products for applications like refractory bricks, insulator tubes, crucibles etc. But, alumina components for electronic and similar high-tech applications are still imported. The drawback of pure alumina for electronic applications is the large temperature-coefficient of relative permittivity. Currently imported alumina ceramics suffer from high drift of dielectric constant with temperature and need firing temperature above 1600°C. But, the compensated alumina (ComAl), developed by VSSC, has near-zero temperature coefficient and can be sintered at ≤1475°C.

The ceramic has alumina as major content and a couple of additives and dopants. The powder of ComAl can be suitably processed further for making bulk products as per requirement. Bulk green bodies can be fired at ≤1475°C for less than 2h to get sintered ceramic. Sintered products can be polished, sliced or cut or machined for various applications. Typical properties of bulk ceramics are shown below

Firing temperature(°C)	1450 – 1475
Bulk density (g/cc)	3.9 ± 0.1
Resistivity (Ω.cm)	>109
Coeff. of Thermal Expansion (10 <sup>-6</sup> /K)	7 – 7.2
Thermal conductivity (W/m.K)	24 – 30
Dielectric constant (er) @ 5GHz	11 – 12
Loss factor (tand, 10 <sup>-5</sup> ) @ 6 GHz	< 7
Qu of resonator @ 12GHz	> 10,000
Temp. coeff. of frequency (τf, ppm/K)	0 ± 5

## APPLICATION AREAS:

ComAl ceramics can replace conventional alumina ceramics in various electrical, electronic and RF applications.

VSSC is willing to offer the technology of ComAl to eligible interested parties who are in the field of manufacturing similar items

Interested entrepreneurs are requested to contact the address given below with all relevant particulars regarding their line of current activity, infrastructure available, market assessment of the product, financial arrangements made, turn over and sales of their products for the past years and a copy of their latest annual report.

## Technology Transfer from ISRO

ISRO is willing to offer the knowhow of this technology to suitable entrepreneurs / industries in India. Capable manufacturing industries interested in acquiring this knowhow may write with details of their present activities, requirements and plans for implementation, infrastructure and technical expertise available with them, their own market assessment, if any, and plans for diversification to the address given below:

NewSpace India Limited (NSIL)

Email: [contact-nsil@isro.gov.in](mailto:contact-nsil@isro.gov.in)

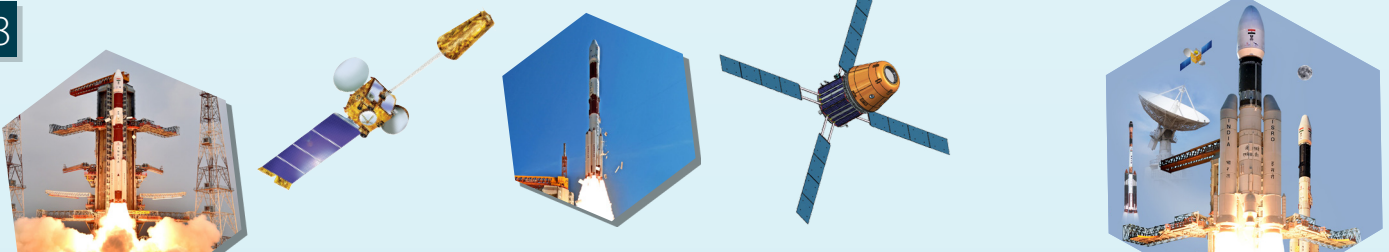



# Silicone Polymer Based Low Density Syntactic Foam TPS, SSF P-70

SSF P-70 is a low density thermal protection system based on silicone polymer, with microballoon and other fillers as compounding ingredients. This TPS is room temperature curable and can be applied by brushing and spraying techniques. The remarkable features of this system include lower density of 0.38 g/cc, lower thermal conductivity, high specific heat, good ageing resistance and compatibility with wide variety of substrates. Indian Space Research Organisation (ISRO) at its Vikram Sarabhai Space Centre (VSSC) has developed a technology for processing and application of different types of silicone polymer based thermal protection systems with tailored properties to meet various mission/application requirements.

The processing involves incorporation of selected quality fillers and ingredients in specific type of silicone polymer resin and use of suitable curatives to achieve desired thermo-physical properties.

## Salient Features

- Simplified and cost effective technology for processing premium quality thermal protection system.
- Room temperature curable.
- Flexibility with respect to application procedure such as spraying and brushing.
- Compatibility with wide variety of substrates including metals, composites etc.
- Excellent ageing behaviour, making it suitable for long term application with no deterioration of properties for more than 2 years.

## Applications

- Useful for light weight, high quality thermal protection system for temperatures up to 3000C direct exposure with reasonable stability and capability to retain properties. The system also

has good aging characteristics. The system can be applied to desired thickness depending upon the thermal environment envisaged. Reasonable mechanical strength and adhesive properties with large number of substrates has been demonstrated by the system. Ability to retain properties at temperatures up to 150 0C and low temperature flexibility are other highlights of the system owing to the low glass transition characteristics associated with silicone polymers.

- The product can be used for thermal protection application for protecting rocket hardware form aerodynamic heating where light weight TPS is required and also as moisture / water impermeable coatings.
- The system can be tailored for use as coating on metal substrates for outdoor use.

## Technology Transfer from ISRO

ISRO is willing to offer the knowhow of this technology to suitable entrepreneurs /industries in India. Capable manufacturing industries interested in acquiring this knowhow may write with details of their present activities, requirements and plans for implementation, infrastructure and technical expertise available with them, their own market assessment, if any, and plans for diversification to the address given below.

NewSpace India Limited (NSIL)  
Email: [contact-nsil@isro.gov.in](mailto:contact-nsil@isro.gov.in)

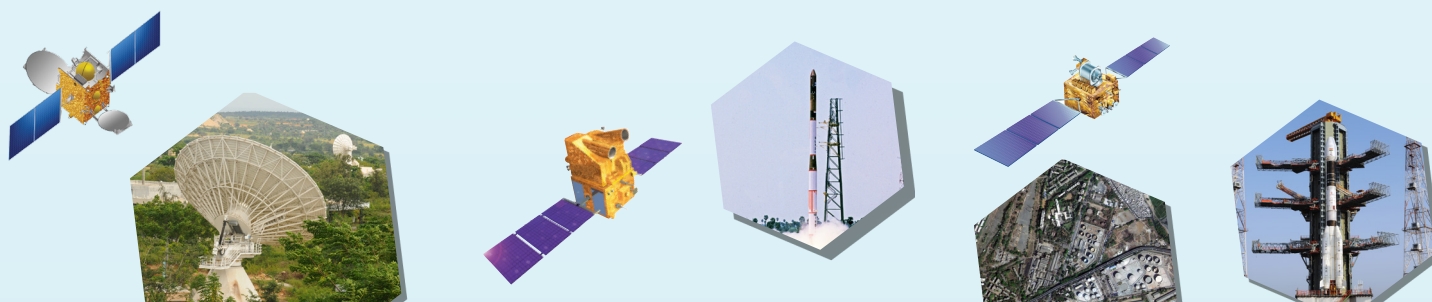

# Dk65 Ceramic For Microwave Applications

DK65 ceramic is a type of dielectric ceramic with high relative permittivity or dielectric constant ( $\epsilon_r \sim 65$ ) and low dielectric loss ( $\tan\delta < 10^{-3}$ ) at microwave frequencies. VSSC has developed this ceramic technology through conventional solid state route. The ceramics can be fired to full density by firing below 1400°C in air atmosphere furnaces. The ceramic has been successfully tested as dielectric resonators and as patch antenna in L-bands. Since this ceramic possesses very small drift in dielectric constant with temperature, it is useful for applications like dielectric resonator filters, substrates for GPS, NAVIC patch antennas, dielectric resonator antennas etc., in UHF to C-band of microwave frequencies.

The nominal properties of DK65 ceramic are given below.

Bulk density (g/cc)	5.3- 5.5
Dielectric constant ( $\epsilon_r$ )	$64 \pm 2$
Unloaded Quality factor ( $Q_u$ @ 3 GHz)*	3200-3600
Loss factor ( $\tan\delta$ , $10^{-4}$ ) @ 3 GHz	$\leq 2.65$
Temp. coeff. of frequency in 25-75°C ( $\tau_f$ , ppm/K)*	$0 \pm 5$

\* Properties are obtained by testing in microwave frequency range by standard resonance method

## Technology Transfer from ISRO

ISRO is willing to offer the knowhow of this technology to suitable entrepreneurs / industries in India. Capable manufacturing industries interested in acquiring this knowhow may write with details of their present activities, requirements and plans for implementation, infrastructure and technical expertise available with them, their own market assessment, if any, and plans for diversification to the address given below:

NewSpace India Limited (NSIL)  
Email: [contact-nsil@isro.gov.in](mailto:contact-nsil@isro.gov.in)

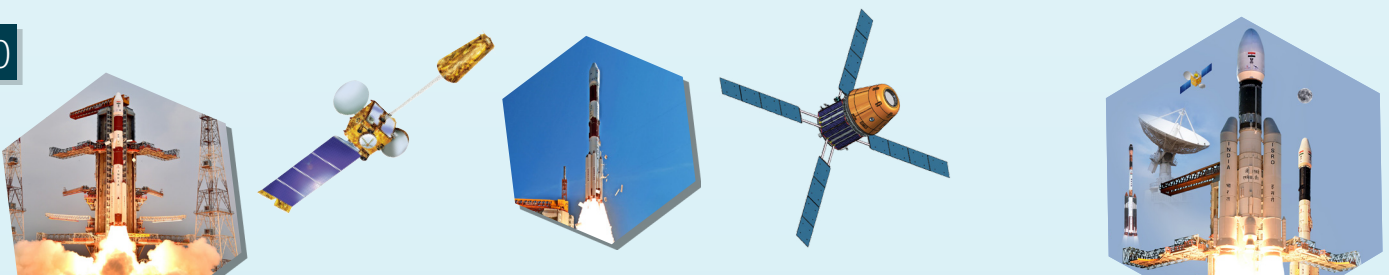

# Low Modulus Flex Seal Compound

Flex Nozzle Control (FNC) is one among the thrust vector control system used in solid rocket propulsion. The system enables the submerged nozzle to be vectored in all directions and to a limited angle, by an actuation system, as the nozzle is connected to the main motor through a flexible joint. The flex seal is made up of alternate layers of metallic shims and elastomeric pads. Natural rubber based elastomeric pads are found to be most suitable element for this application because of its easiness with which it can be formulated to give low shear modulus coupled with high shear strength. The method is further recommended for large size flex seals for bigger size boosters of ISRO.

The technology for realization of this low modulus flex seal rubber compound using Natural rubber, ISNR grade is offered for industrial application. The complete formulation, processing/compounding, process parameter selection, specimen preparation, property evaluation, storage and shelf life are detailed, for the developed material. The material exhibits excellent rubber to metal and rubber to carbon-carbon composite interface adhesion, enabling it for use as multilayer structural element and leak free joint.

## Salient Features

- Low shear modulus
- High shear strength
- Amenable for extrusion, transfer and compression moulding processes
- Good rubber to metal and rubber to carbon epoxy composite interface property

Sl. No.	Properties of Low modulus flex seal compound	
1	Tensile strength, ksc	100 (Min)
2	Elongation at break, %	600 (Min)
3	Hardness, Shore A	40 (Max)
4	Shear strength, ksc	20 (Min)
5	Shear strain, %	700 (Min)
6	Shear modulus, ksc @ 3.57 ksc shear stress	1.6-2.0
7	Compression set @ 70degC/22hrs, %	40 (Max)

## Applications

- Submerged flex nozzle vectoring unit
- Anti-vibration structural element

## Technology Transfer from ISRO

ISRO is willing to offer the knowhow of this technology to suitable entrepreneurs / industries in India. Capable manufacturing industries interested in acquiring this knowhow may write with details of their present activities, requirements and plans for implementation, infrastructure and technical expertise available with them, their own market assessment, if any, and plans for diversification to the address given below:

NewSpace India Limited (NSIL)  
Email: [contact-nsil@isro.gov.in](mailto:contact-nsil@isro.gov.in)

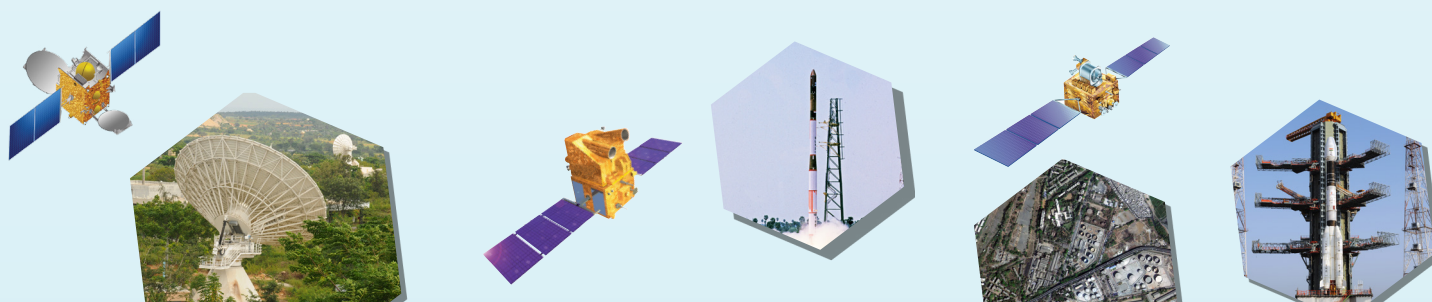

# Niti Based Shape Memory Alloys

Shape Memory Alloys (SMA's) are metallic materials, which have the ability to return to a predetermined shape when heated. The most common Shape Memory Metallic Material is an alloy of Nickel and Titanium called Nitinol. Indian Space Research Organisation (ISRO) at Vikram Sarabhai Space Centre (VSSC) has developed a technology for processing NiTi based Shape Memory Alloys of uniform homogeneity with good control on deleterious impurities like Carbon, Nitrogen and Oxygen contamination.

The method consists of materials arrangement inside graphite crucible, melting under argon atmosphere and finally casting.

## Salient Features

- Simplified and Cost effective technology for processing premium quality billets in NiTi base SMA's and other reactive alloys
- Homogeneous product with excellent control in impurities
- Achieves economy in cost and labour and saves time by eliminating the repeated vacuum arc remelting
- Unique way of materials arrangement in the high density graphite crucible to reduce the contamination of the NiTi melt from the crucible
- Special tailor made vacuum induction facility for controlling carbon and oxygen contamination in making NiTi SMA's

## Applications

- Useful in economical processing of high quality cast billets in NiTi SMA's with low carbon,

nitrogen, hydrogen and oxygen contamination. These billets can be used to realize wrought products like Plates, Sheets, Foils, Wires, Sleeves, Forged, Rolled and extruded products through further mechanical working. Inclusion content in the billets processed through this technique is very low; hence very thin wires can be drawn without much problem from extruded rods processed from these billets.

- The products can be used for realization of collapsible antennas, collars for separation systems, couplings, stepper drive mechanism to drive flaps of satellites, etc.
- SMA's have high potential for use in biomedical industries as Bone Plates, Stents, Orthodontic Wires etc.

## Technology Transfer from ISRO

ISRO is willing to offer the knowhow of this technology to suitable entrepreneurs / industries in India. Capable manufacturing industries interested in acquiring this knowhow may write with details of their present activities, requirements and plans for implementation, infrastructure and technical expertise available with them, their own market assessment, if any, and plans for diversification to the address given below:

NewSpace India Limited (NSIL)  
Email: [contact-nsil@isro.gov.in](mailto:contact-nsil@isro.gov.in)



# Ceramic Foam (HTFOAM-1500) By Direct Foaming Technique

HTFOAM-1500 are ceramic foams Silicon carbide (SiC)/Silicon Oxycarbide foam (SiOC) made by direct foaming technique. HTFOAM-1500 has very high operational temperature capability of 1500°C under oxidation atmosphere. The light weight ceramic foam possesses both open and closed cells with good strut density and high compressive strength. They have very low thermal conductivities and hence suitable for various applications viz., thermal insulators, micro-meteoroid and orbital debris (MMOD) shield, electromagnetic shielding and as CMC based sandwich constructions for internal multiscreen applications.

## Salient Features

- Ceramic foam (SiC) foam with temperature capability of 1500°C under oxidizing atmosphere.
- Open cell porosity, closed cell porosity, strut thickness can be optimized by varying the processing parameters.
- Compressive strength and thermal conductivity can be optimized by varying the processing parameters and polymer composition.

Properties	Values
Bulk density (g/cc)	0.23-0.35
Total porosity (%)	80-95
Open porosity (%)	20-35
Closed porosity (%)	65-80
Compressive strength (MPa)	0.2-3.0
Thermal conductivity (W/mK) at RT	0.1-0.2

## Technology Transfer from ISRO

ISRO is willing to offer the knowhow of this technology to suitable entrepreneurs / industries in India. Capable manufacturing industries interested in acquiring this knowhow may write with details of their present activities, requirements and plans for implementation, infrastructure and technical expertise available with them, their own market assessment, if any, and plans for diversification to the address given below:

NewSpace India Limited (NSIL)

Email: [contact-nsil@isro.gov.in](mailto:contact-nsil@isro.gov.in)

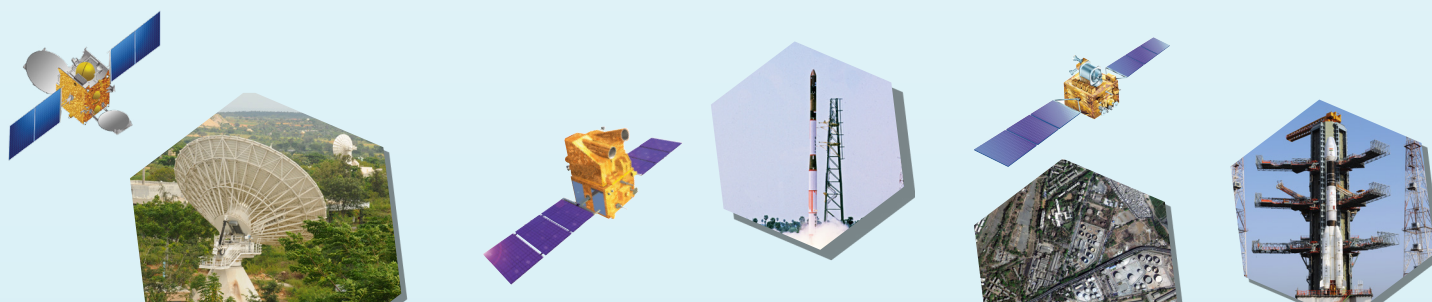

# SiC Foam Tile SICTILE-1650 by Replica Technique

SICTILE-1650 (in the form of tiles of 200x200x20 mm) is an open cell SiC foam tile formed by replica technique that has very high operational temperature capability of 1650°C under oxidation atmosphere. They possess good handling strength with 80-90% open cell porosity. Light-weight SiC foam based sandwich structures are used for thermal protection systems for aerospace applications. They can be used as volumetric absorbers in the generation of large amounts of electricity by concentrated solar power (CSP) technology. They can also be used as electromagnetic wave absorbing materials and porous burners.

## Salient Features

- Open cell silicon carbide foam based tile with temperature capability of 1650°C under oxidizing atmosphere.
- Open cell porosity, pore size, strut thickness can be optimized by varying the processing conditions.
- Handling strength can be improved by varying the pore size and density.
- Thermal conductivity can be optimized by varying the processing parameters and density.

Properties	Values
Bulk density (g/cc)	0.3-0.8
Open porosity (%)	80-95
Compressive strength (MPa)	1-3
Thermal conductivity (W/mK) RT	0.1-0.3 ( $\rho=0.15-0.2$ g/cc)
Coefficient of thermal expansion ( $\mu\text{m}/^\circ\text{C}$ ) (RT-800°C)	0.5- 2

## Technology Transfer from ISRO

ISRO is willing to offer the knowhow of this technology to suitable entrepreneurs / industries in India. Capable manufacturing industries interested in acquiring this knowhow may write with details of their present activities, requirements and plans for implementation, infrastructure and technical expertise available with them, their own market assessment, if any, and plans for diversification to the address given below:

NewSpace India Limited (NSIL)

Email: [contact-nsil@isro.gov.in](mailto:contact-nsil@isro.gov.in)

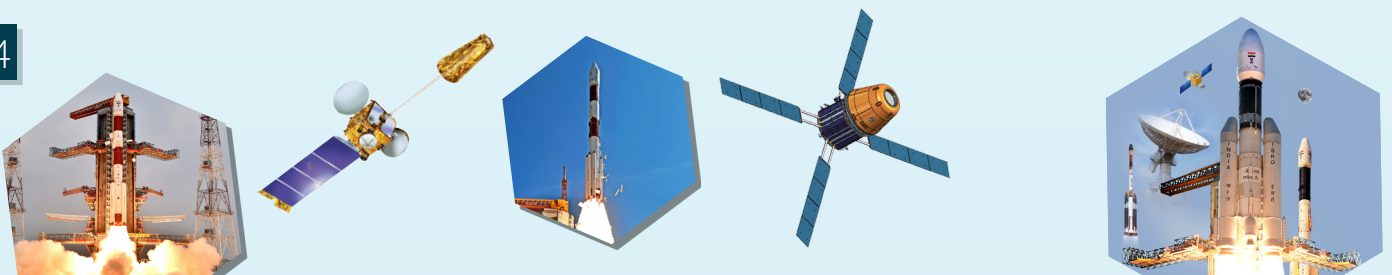

# Strontium Perchlorate

Strontium Perchlorate is produced by various process operations like Crystallization of Sodium perchlorate (SPC) crystals, Production of Perchloric Acid, Purification of Perchloric Acid, Production of Strontium Perchlorate and Concentration of Strontium Perchlorate solution.

## Properties

- Purity as Strontium perchlorate (w/w) :  $68 \pm 3\%$
- Colour and appearance : Clear straw coloured
- Specific gravity at 28 oC :  $1.90 \pm 0.01$
- Viscosity at 28 oC :  $12 \pm 3$  centi poise
- Acid value (mg of KOH/ g) : 0.6 (max)
- pH of 10% Solution : 4.5 - 6.0
- Chlorate as  $\text{ClO}_3^-$  : 0.25%
- Chloride as  $\text{Cl}^-$  : 0.1%
- Suspended matter : Nil

## Applications

Secondary injection thrust vector control in launch vehicles

## Technology Transfer from ISRO

ISRO is willing to offer the knowhow of this technology to suitable entrepreneurs / industries in India. Capable manufacturing industries interested in acquiring this knowhow may write with details of their present activities, requirements and plans for implementation, infrastructure and technical expertise available with them, their own market assessment, if any, and plans for diversification to the address given below:

NewSpace India Limited (NSIL)

Email: [contact-nsil@isro.gov.in](mailto:contact-nsil@isro.gov.in)

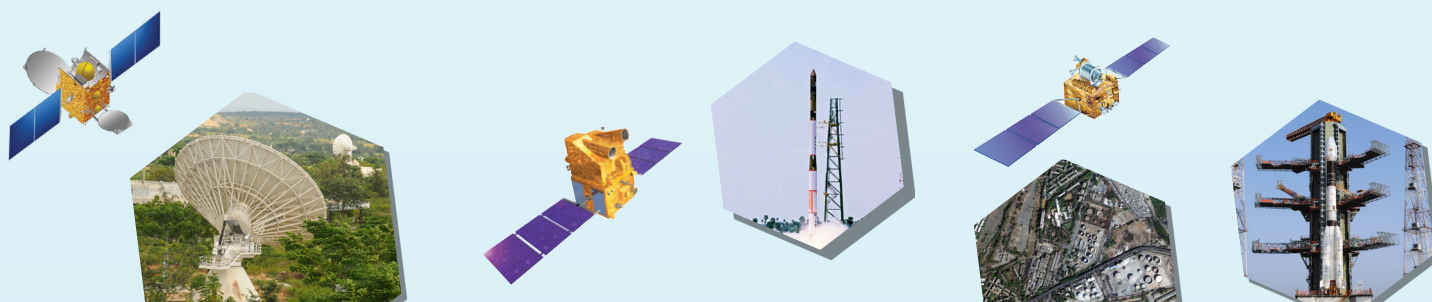

# High Density Sintered Silicon Carbide

Silicon carbide is widely used for high temperature applications. Due to its unique characteristics like excellent low density, high thermal shock resistance, oxidation resistance SiC based materials are also extensively used in optical systems due to low CTE and high thermal conductivity. However, due to the sintering difficulty of silicon carbide, it is difficult to obtain dense SiC. A process is developed through hot pressing procedure and using small quantity of sintering aids (<5wt%) to manufacture SiC with near theoretical density and excellent combination of mechanical and thermal properties.

The nominal properties of High density SiC ceramic are given below

Density, g/cc	3.22 (99.8% of theoretical)
Flexural strength, MPa	450
Compressive strength, GPa	1.9
Fracture toughness, MPa $\sqrt{m}$	4.5
Elastic modulus, GPa	350
Thermal conductivity, W/mK	>80
Specific heat, J/Kg/°C	610
Coefficient of thermal expansion (RT to 500°C), °C <sup>-1</sup>	< 2.5 x 10 <sup>-6</sup>
Electrical resistivity, $\Omega$ -cm	2.6 x 10 <sup>9</sup>

## Technology Transfer from ISRO

ISRO is willing to offer the knowhow of this technology to suitable entrepreneurs / industries in India. Capable manufacturing industries interested in acquiring this knowhow may write with details of their present activities, requirements and plans for implementation, infrastructure and technical expertise available with them, their own market assessment, if any, and plans for diversification to the address given below:

NewSpace India Limited (NSIL)

Email: [contact-nsil@isro.gov.in](mailto:contact-nsil@isro.gov.in)

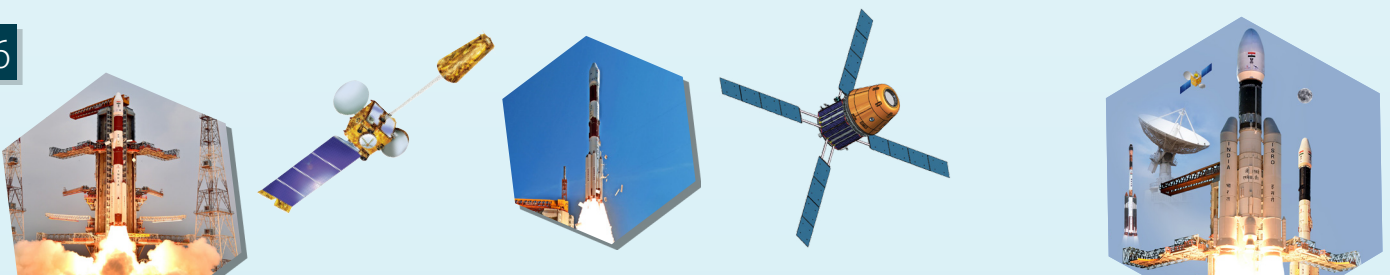



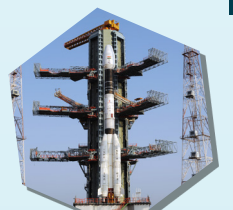
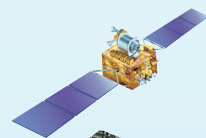
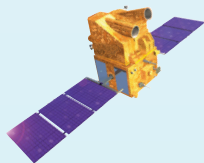
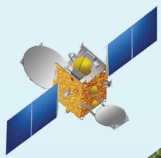

LIST OF INDUSTRIES

1	KELTRON, Thiruvananthapuram
2	Fyrkool Pvt. Ltd, Hosur
3	Varsha Engineering Works, Gujarat
4	Star Agencies, Baroda
5	Hindustan Aeronautics Ltd, Lucknow
6	Gujarat Communication & Electronics Ltd (GCEL), Baroda
7	Encardiorite Electronics Pvt. Ltd, Lucknow
8	New Engineering Enterprises, Rourkee
9	Hydraulic & Engineering Instruments, New Delhi
10	Fluid Power Engineers, Belgaum
11	IDL Chemicals Ltd, Hyderabad
12	Span Industries, Kolhapur
13	Malabar Polyols & Allied Products Ltd, Kuttipuram
14	Indian Drugs & Pharmaceuticals Ltd., Hyderabad
15	Electronics Corporation of India Ltd (ECIL), Hyderabad
16	Shyam Antenna, New Delhi
17	Meltron, Bombay
18	UMS Radio Factory, Coimbatore
19	MCE Products, New Delhi
20	Television Factory, Shimla
21	Sundaram Industries, Madurai
22	Madras Industrial Linings, Madras
23	Hyderabad Batteries Ltd, Hyderabad
24	Andhra Pradesh Small Scale Industrial Development Corporation Ltd., Hyderabad
25	NIL, Calcutta
26	Hind High Vacuum Co. Ltd, Bangalore
27	Bharat Heavy Electricals Ltd., Bangalore
28	IVP Ltd, Bombay
29	United Electrical Industries Ltd, Quilon
30	Watts Electronics Pvt. Ltd, Cochin
31	Insulex Chemicals Pvt. Ltd, Pune
32	Bharat Electronics Limited (BEL), Bangalore

33	Optomech Engineers, Hyderabad
34	Dynascan Inspection Systems, Bangalore
35	Doschen India Ltd, Bombay
36	Speck Systems, Hyderabad
37	Micro Documentation, Secunderabad
38	Tech Invest (India) Pvt. Ltd, Hardwar
39	Pravin Reinforced Plastics Pvt. Ltd, New Delhi
40	Kalpna Glass Fibres, Pune
41	Pyromasters, Trivandrum
42	Unnati Corporation, Ahmedabad
43	NITEL, Bhopal
44	Defence Research & Devp. Lab (DRDL), Hyderabad
45	RDSO, Lucknow
46	CMC Ltd, Secunderabad
47	Trumps Software, Chennai
48	Andhra Sugars Ltd, Tanuku
49	National Organic Chemical Industries Ltd, Bombay
50	Indian Telephone Industries (ITI), Bangalore
51	Remote Sensing Instruments, Hyderabad
52	Sita Electronics, Hyderabad
53	Reliance Silicones, Bombay
54	Industrial Control & Appliances Pvt. Ltd, Bombay
55	Ordnance Factory Board, Calcutta
56	Thermax Pvt. Ltd, Pune
57	Apollo Microsystems, Hyderabad
58	Elico Pvt. Lt, Hyderabad
59	Optical Coatings Laboratories, Bangalore
60	Titanium Tantalum, Madras
61	Nagaraja Industries, Hassan
62	Tamil Nadu Industrial Explosives, Vellore
63	Coromondal Prodorite, Madras
64	Hindustan Computers Ltd (HCL), New Delhi
65	Tata Electric Co., Bombay
66	High-Tech Optics, Hyderabad
67	Harvin Optical & Glass Industries, Hyderabad

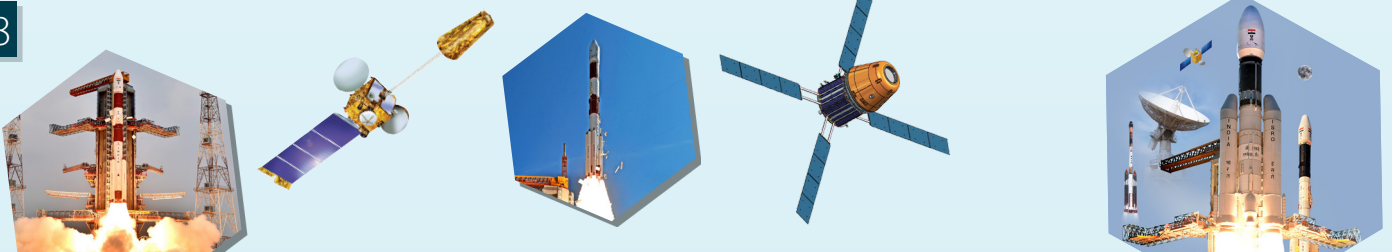

68	Deccan Safety Glass Ltd, Madras
69	Tata Tea Ltd, Kerala
70	Fafeco Engineers, Bombay
71	Ovis Equipment, Hyderabad
72	Electric Control Gear (India) Ltd, Ahmedabad
73	Saichem, Chennai
74	Valeth High Tech. Composites Pvt. Ltd., Madras
75	ITW Signode India Ltd, Hyderabad
76	Softech India, Trichur
77	Shri. M. Vijayakumar, Thiruvananthapuram
78	Nebula Chemicals, Bombay
79	Madras Metallurgical Services Pvt. Ltd, Madras
80	Hifin Products , Mumbai
81	Microscan Instruments Pvt. Ltd, Hyderabad
82	Precipitated Silicos, Vijayawada
83	Govind Chemicals, Trichur
84	Vijayadurga Enterprises, Udrajavaram
85	Trikuta Chemicals, Jammu
86	Lakshman Chemicals, Davangere
87	Yash Papers, Faziabad
88	Karthik Chemicals, Madras
89	Banmshihari Rice Mills, Calcutta
90	Gupta Rubber Products
91	Avee Industries, Ambala Cant
92	Punjab Agro Industries, Chandigarh
93	Gujarat Alkalies and Chemicals Ltd, Vadodara
94	Glasstics India, Madras
95	Machine Products, Ahmedabad
96	MCBs Pvt Ltd, Ahmedabad
97	Astrooptics, Bombay
98	Larson & Toubro (L&T), Bombay
99	Kaushik Enterprises, Bangalore
100	Sur Fire Equipment, Calcutta
101	Gitanjali Enterprises, Madras
102	KV Fire Chemicals (I) Ltd, Bombay
103	Fire Safety Devices Pvt Ltd, Faridabad
104	Kemex international Pvt Ltd, Mumbai

105	Sameer, Bombay
106	ABR Organics, Hyderabad
107	Sujal Plastics Work, Ahmedabad
108	General Optics (Asia) Ltd, Pondicherry
109	Hytronics Enterprises, Hyderabad
110	Polygon Instrumentation & Aids Pvt. Ltd, Bangalore
111	Dynaspede Integrated Systems Pvt. Ltd, Hosur
112	Era Electronics (India), Hyderabad
113	Pegasus Software Consultants Pvt. Ltd., Bangalore
114	Maharshi Electronics Systems, Ahmedabad
115	Systech Pvt. Ltd, Pune
116	Zoom Technics, Hyderabad
117	Instrumentation Ltd, Kota
118	Dynalog Marketing Services, Bangalore
119	C-DAC, Pune
120	RCL Ltd, Jaipur
121	Andhra Electronics, Hyderabad
122	Karnataka Tele Electronics Pvt Ltd, Bangalore
123	Tata Telecom Ltd, Gandhinagar
124	Himachal Futuristic Commn Ltd, Solan
125	Electromag Devices, Bombay
126	Comsat Systems Pvt. Ltd, Hyderabad
127	Optical Systems & Components, Hyderabad
128	Aries Engineering Ltd, Coimbatore
129	Syscon Instruments Pvt. Ltd, Bangalore
130	Macurex Sensors Pvt. Ltd, Bangalore
131	Kerala Hightech Industries Ltd, Thiruvananthapuram
132	Brother Surgicals Ltd, Bangalore
133	Ananth Microtronics, Hyderabad
134	ESL, Gandhinagar
135	Zoom Technics, Hyderabad
136	RSK Enterprises, Hyderabad
137	Susee Spacetek, Hyderabad
138	Avantel Communication Ltd, Hyderabad
139	PK Industries, Bangalore
140	Multi Arc India, Bombay

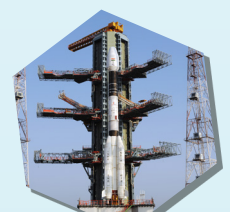
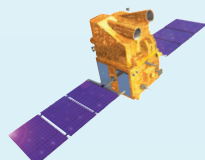
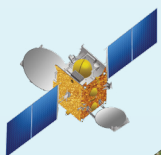

141	Opto Electronics Factory, Dehradun
142	Shreyas Engineers, Bangalore
143	Stylus Wares, Trivandrum
144	Reliable Wares, Thrissur
145	Prayag Polymers Ltd, New Delhi
146	MTAR, Hyderabad
147	Bharat Electronics Systems, Gandhinagar
148	Rishab Resins & Chemicals, Hyderabad
149	Sumeru Microwave Communications, Ahmedabad
150	Thankerson, Pune
151	ER Automotives, Rothak
152	MM Engineers Pvt. Ltd, Coimbatore
153	Chennai Automation, Chennai
154	Space Products India (P) Ltd, Trivandrum
155	Legend Technologies, Bangalore
156	ADA, Bangalore
157	IPA Pvt Ltd, Bangalore
158	Avasarala Automation Ltd, Bangalore
159	Hydro Control Pvt. Ltd, Bangalore
160	Astra Microwave Products Ltd, Secundrabad
161	Accord Electronics, Mumbai
162	Holmarc Slides and Controls Pvt. Ltd, Kochi
163	Bhagavan Mahavir Vikalanga Sahayatha Samithi, Jaipur
164	Dymnamic Techno Medicals Pvt. Ltd, Aluva
165	Accord Network (I) Pvt. Ltd, Thane
166	Anabond Ltd, Chennai
167	Satcom Technologies, Hyderabad
168	Navanidhi Electronics, Hyderabad
169	Pashupathi Acrylon Ltd, Moradabad
170	M/s Resistoflex, Noida
171	Elastomeric Engineers, Salem
172	M/s Cosmotone Conductors Ltd., Moovattupuzha
173	Solvosol Paints Pvt Ltd, Hyderabad
174	komopier Explosives, Secunderabad
175	Infnium (India) Limited, Ahmedabad
176	MIDAS Communication, Chennai
177	West Coast Polymers, Kannur

178	Beekay Foams, Ernakulum
179	Premier Explosives, Secundrabad
180	Komoline Electronics Pvt Ltd, Ahmedabad
181	High Energy Batteries, Hyderabad
182	Scanpoint Geomatics Ltd, Ahmedabad
183	VXL Technologies Ltd, Faridabad
184	Light Logics Holography and Optics Pvt Ltd, Thiruvananthapuram
185	AE Telelinks System Ltd, New Delhi
186	Opel India, Pune
187	Holmarc Opto Mechatronics Private Limited, Cochin
188	Surelia Wire Cut Private Limited, Rajkot
189	Technocom Dies & Precision Products, Rajkot
190	Ants Ceramics Private Limited, Nashik
191	Tulsi Industries, Ahmedabad
192	Metreat Engineers, Ahmedabad
193	Performance Polymers, Bangalore
194	Rubfila international Pvt Ltd, Palakkad
195	Sahajanand Laser Technology Ltd., Gandhinagar
196	Centum Electronics, Bangalore
197	Fine Finish Organics, Mumbai
198	ZStrand Limited, Bangalore
199	SSP 2000 INC, Hyderabad
200	PRS Permacel, Mumbai
201	Regenesi Industries Pvt. Ltd, Hyderabad
202	Carborundum Universal Ltd
203	Riotech Industries, Pala
204	Intercad Systems, Cochin
205	SVR Infotech, Pune
206	Lakshmi Technology & Engineering Industries Limited, Coimbatore
207	Central Tool Room and Training Centre, Bhubaneswar
208	M/s Atul Industries, Atul, Gujarat
209	M/s Aerospace Materials Pvt Ltd., Coimbatore
210	M/s Prism Circuitronics Pvt. Ltd, Mumbai
211	Optimized Solutions Pvt. Ltd., Ahmedabad

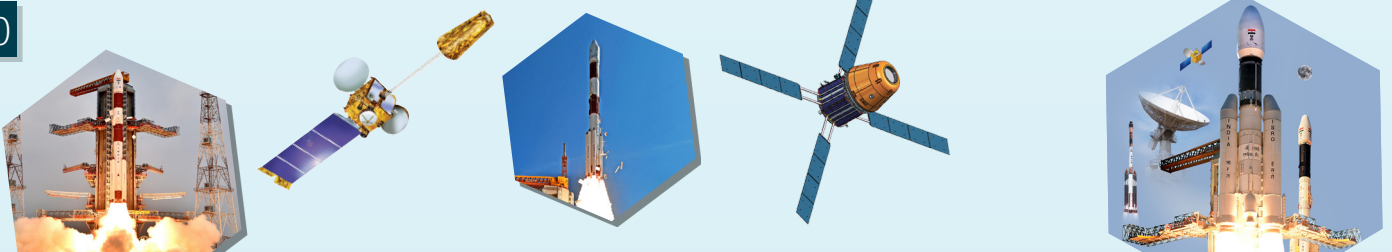

212	M/s Pidilite Industries, Mumbai
213	M/s Aerospace Engineers Pvt Ltd., Salem
214	M/s Ants Innovations, Vasai, MH
215	Sriram Foams Pvt Ltd., Chennai
216	M/s Polyformalin Pvt Ltd, Kochi
217	Kerela State Electronics Development Corporation Limited, Trivandrum
218	Rangsons Defence Solutions Pvt. Ltd., Bengaluru
219	Stesalit Systems Limited, Kolkata
220	VTL Electronics Limited, Kolkata
221	M/s Tempsens Instruments (India) Pvt Ltd
222	M/s Heatcon Sensors

223	M/s NALCO
224	M/s Exicom Systems Pct Ltd
225	M/s Amara Raja Batteries, Tirupati
226	M/s Tata Chemicals Ltd., Mumbai
227	M/s GOCL, Hyderabad
228	M/s Bhukhanwala Industries, Gujarat
229	M/s Siddhi Engineers, Ahmedabad
230	M/s Azista Industries
231	M/s Surmit Enterprises, Ahmedabad
232	M/s Prcyon Techno Industry, Mehsana
233	M/s Pradhan Engineering Company, Ahmedabad
234	M/s Berger Paints, Kolkata
235	M/s C-DAC, Trivandrum

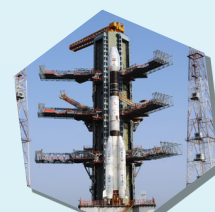
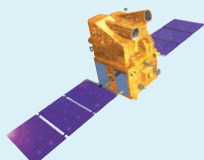
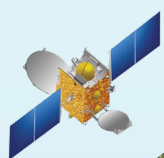

# INDUSTRIES ENGAGED STATE-WISE DISTRIBUTION

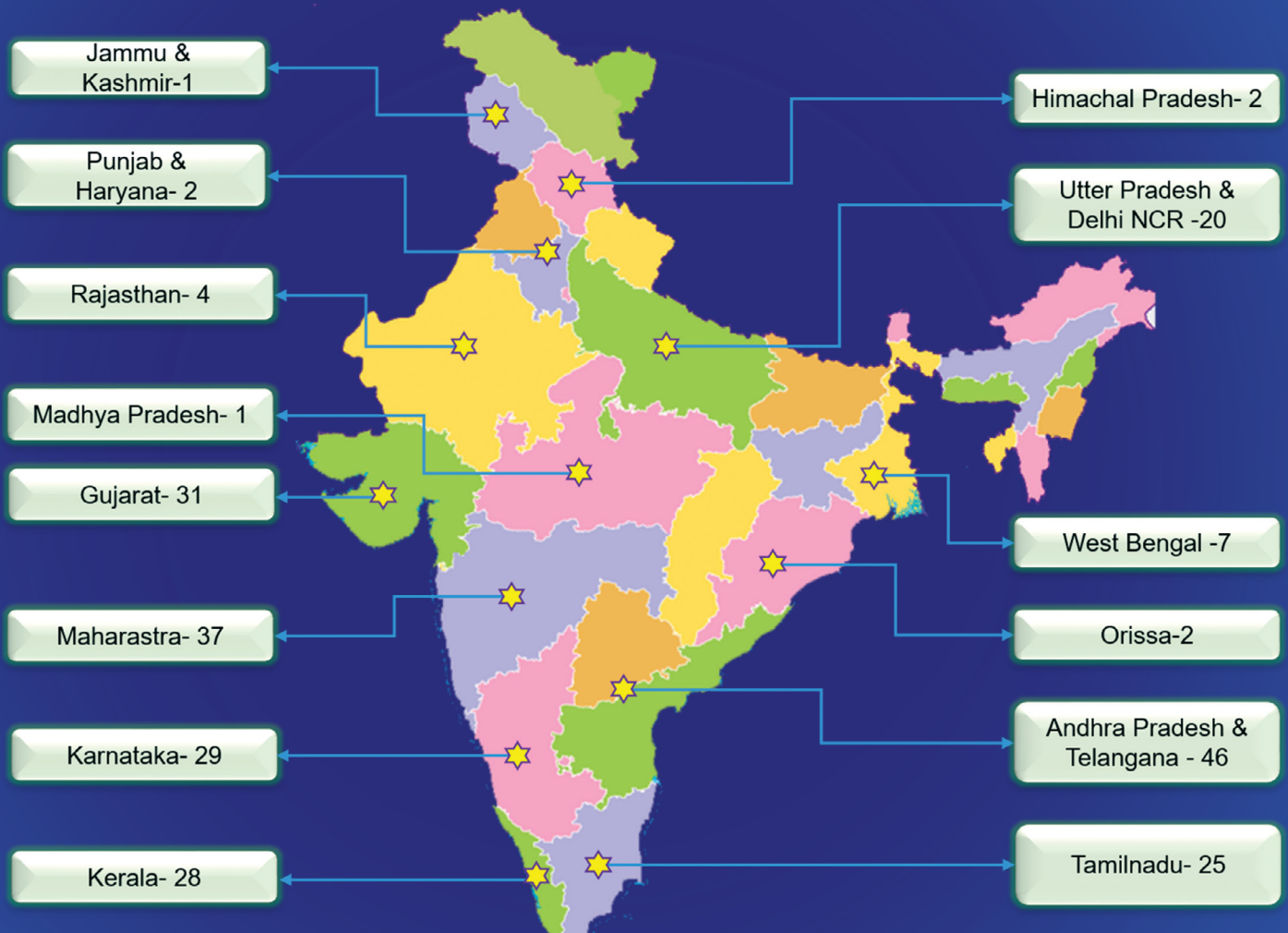

**Capacity Building Programme Office (CBPO)**

**Indian Space Research Organisation**

Department of Space, Government of India

Antariksh Bhavan, New BEL Road, Bengaluru-560094